

Parts List				
ITEM	QTY	ID #	DESCRIPTION	STOCK PART #
1	1	1500P789	Crank Arm Weldment, Extra Heavy Duty	1500P789
2	1	1510P38	Pivot Arm Weldment, (Indicate Length)	
2.1	1	1510P28	Heavy Duty Connecting Arm, Pivot Bar Weldment	
2.2	1	1510P31	Heavy Duty Connecting Arm, Channel Weldment	
2.3	1	1300P127	Jamb Bracket	069500-Z

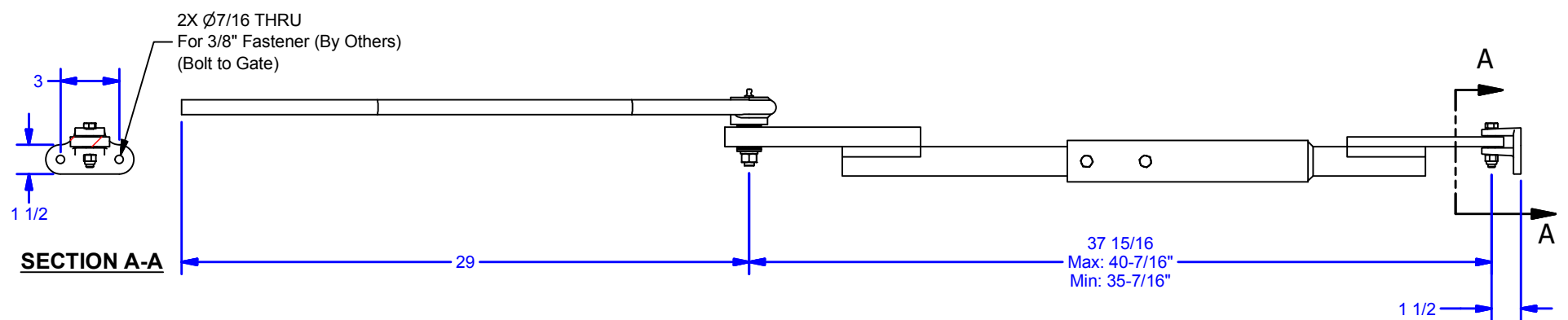
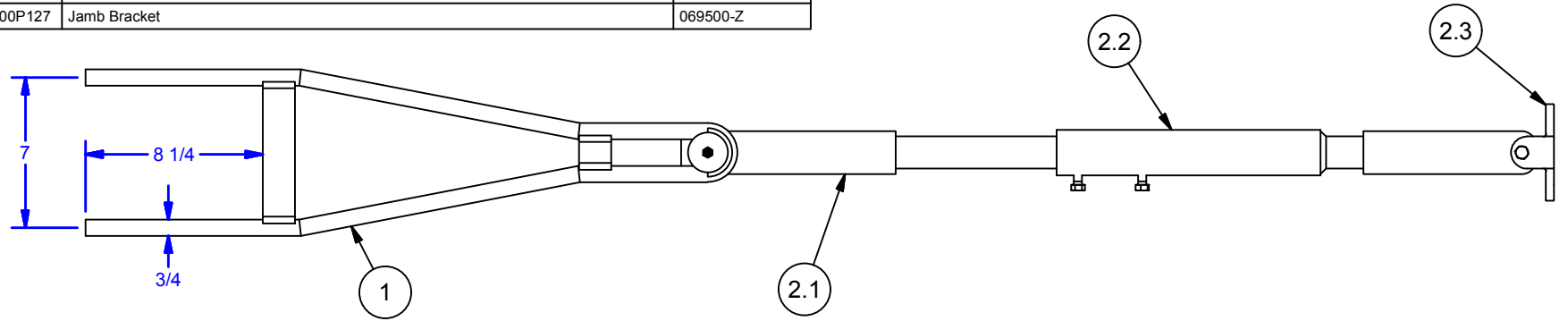

DWG #: 1510P27  
 DRAWN: BCM 4/28/2009  
 SHEET #1  
 File: 1510P27.idw

**ALL DIMENSIONS IN INCHES**

THE INFORMATION CONTAINED IN THIS DRAWING IS THE SOLE PROPERTY OF CROWN INDUSTRIAL. ANY REPRODUCTION IN PART OR AS A WHOLE WITHOUT THE WRITTEN PERMISSION OF CROWN INDUSTRIAL IS PROHIBITED.	ID #:	1510P27	STOCK PART #:	
	MATERIAL:			
DESCRIPTION: 1510 Extra Heavy Duty Connector Arm Assembly				
FINISH:	Ptd.	# PCS:	1	REV:

**CROWN INDUSTRIAL**  
 So. San Francisco, Ca  
 (650) 952-5150  
 www.crown-industrial.com