

4

3

2

1

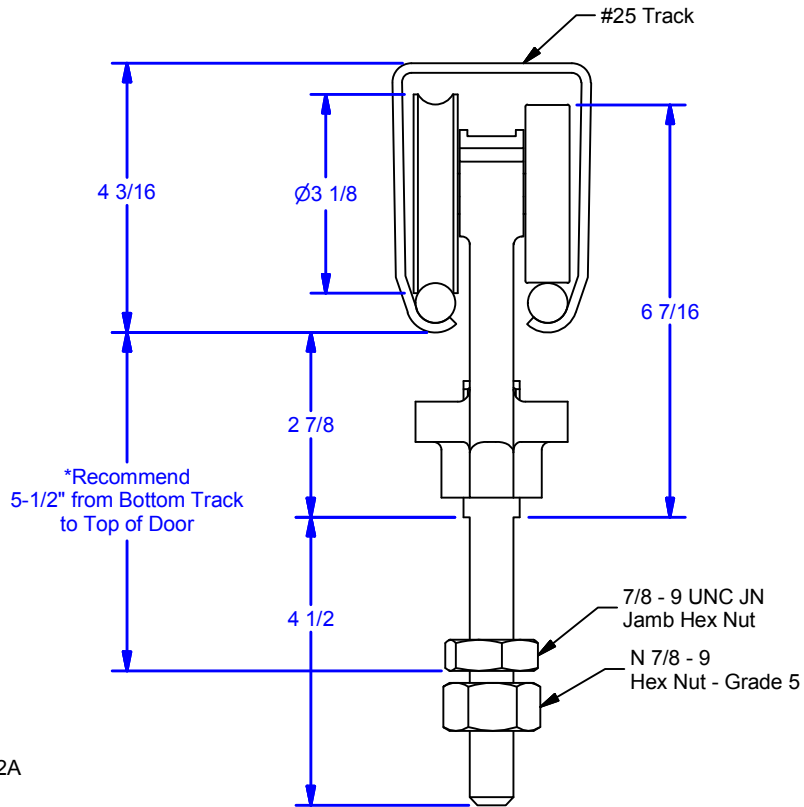
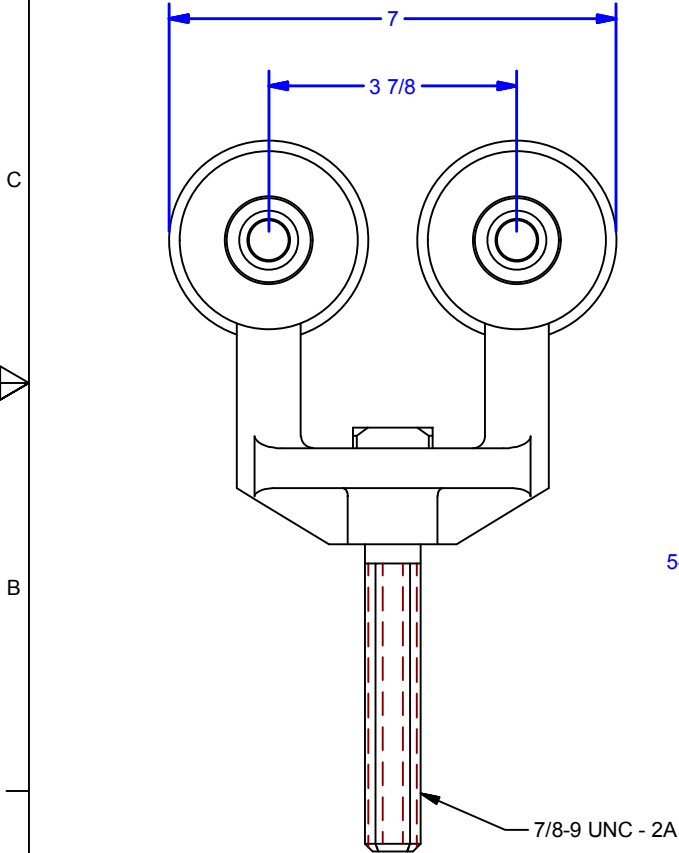
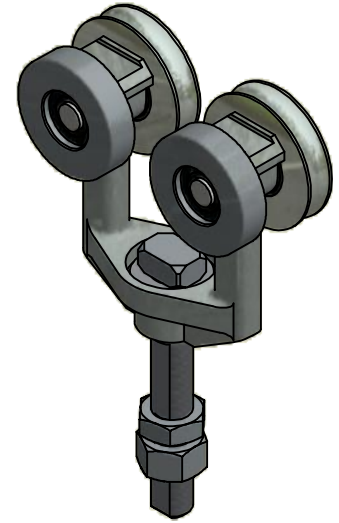
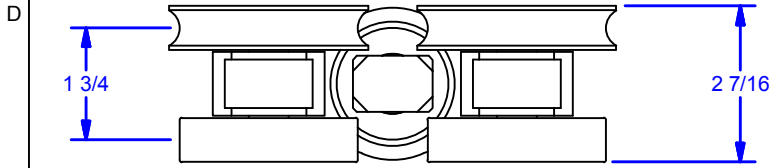

ALL DIMENSIONS IN INCHES

THE INFORMATION CONTAINED IN THIS DRAWING IS THE SOLE PROPERTY OF CROWN INDUSTRIAL. ANY REPRODUCTION IN PART OR AS A WHOLE WITHOUT THE WRITTEN PERMISSION OF CROWN INDUSTRIAL IS PROHIBITED.	ID #:	0000395	STOCK PART #:	25-1BSE
	MATERIAL:			
DESCRIPTION: Truck, Ball Bearing #2500lb Capacity				
FINISH: Zinc	# PCS:	1	REV:	1



CROWN INDUSTRIAL
 So. San Francisco, Ca
 (650) 952-5150
 www.crown-industrial.com

DWG #: 25-1BSE
 DRAWN:BCM 2/12/2009
 SHEET #1
 File: 0000395.idw

4

3

2

1



A

A