

2X Ø9/32 Countersunk Hole
For 1/4 Flat Head Fasteners

(Sidemounted) Outside Keeper for 514P36 Spring Bolt

Face of Door and Opening Header

(Sidemounted) Outside Keeper for 514P36 Spring Bolt

Top Of Door

4X Ø3/8 Countersunk Holes
For 1/4 Flat Head Fasteners

36" Steel Chain with Pull Ring (Not Shown)
#434P112 Additional chain
available upon request

Catches Pull Ring that is attached to Chain
to Hold the Bolt Down (unlocked) position

2X Ø9/32 THRU
For #10 Fasteners

Spring Bolt, Chain Clip

Side Mount Keeper Configuration

FRONT

Available Finishes:
0514.00036: Powder Coat Pebble Tan
0514.00036SC: Powder Coat Black
0514.00036ZC: Clear Zinc Plated

*Includes:
(6 ea.) #14 x 1-1/2" Flat Head Slotted Wood Screws, zinc
(2 ea.) #10 x 3/4" Pan Head Phillips Sheet Metal Screw, zinc

ALL DIMENSIONS IN INCHES

THE INFORMATION CONTAINED IN THIS
DRAWING IS THE SOLE PROPERTY OF
CROWN INDUSTRIAL. ANY REPRODUCTION
IN PART OR AS A WHOLE WITHOUT THE
WRITTEN PERMISSION OF CROWN
INDUSTRIAL IS PROHIBITED.

ID #:	0001630
MATERIAL:	Steel

STOCK PART #:	0514.00036
---------------	------------

DESCRIPTION:
514 P36 Spring Bolt w/ Keeper

FINISH:	# PCS:	REV:
---------	--------	------



CROWN INDUSTRIAL
So. San Francisco, Ca
(650) 952-5150
www.crown-industrial.com

DWG #: 514
DRAWN:BCM 4/17/2014
SHEET #5
File: 0001616.idw

4

3

2

1

D

D

C

C

B

B

A

A

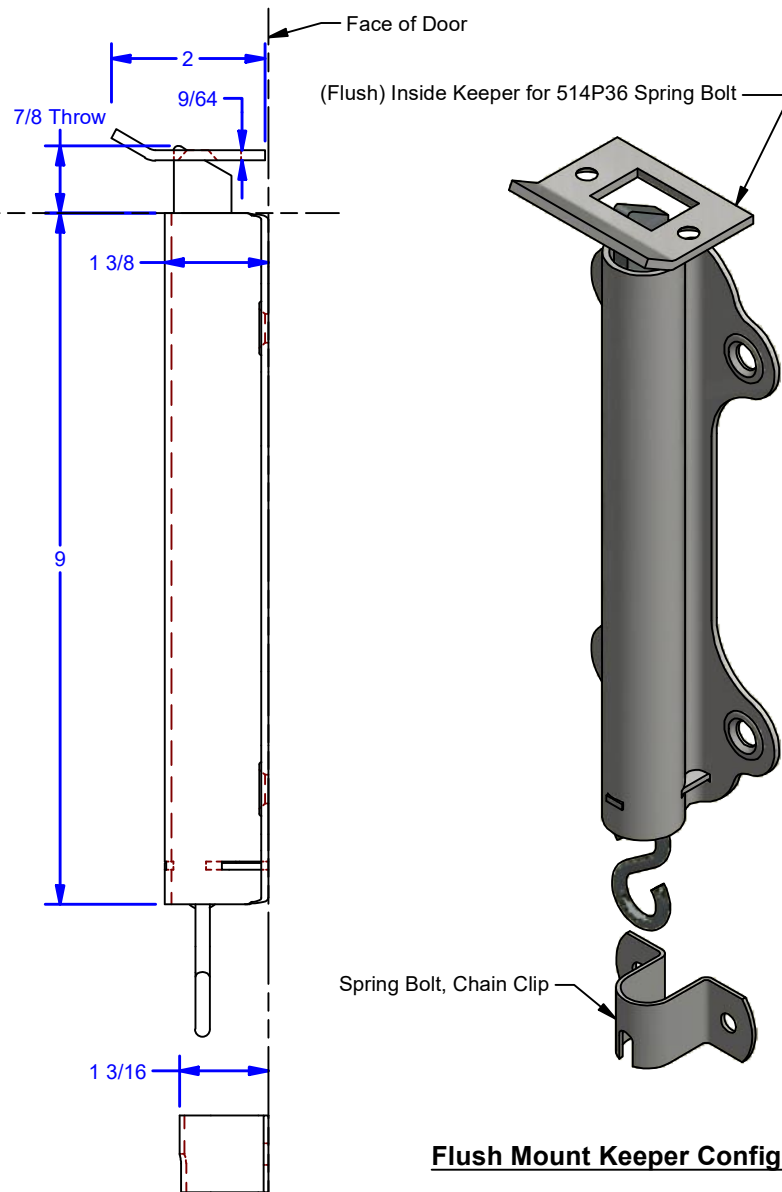
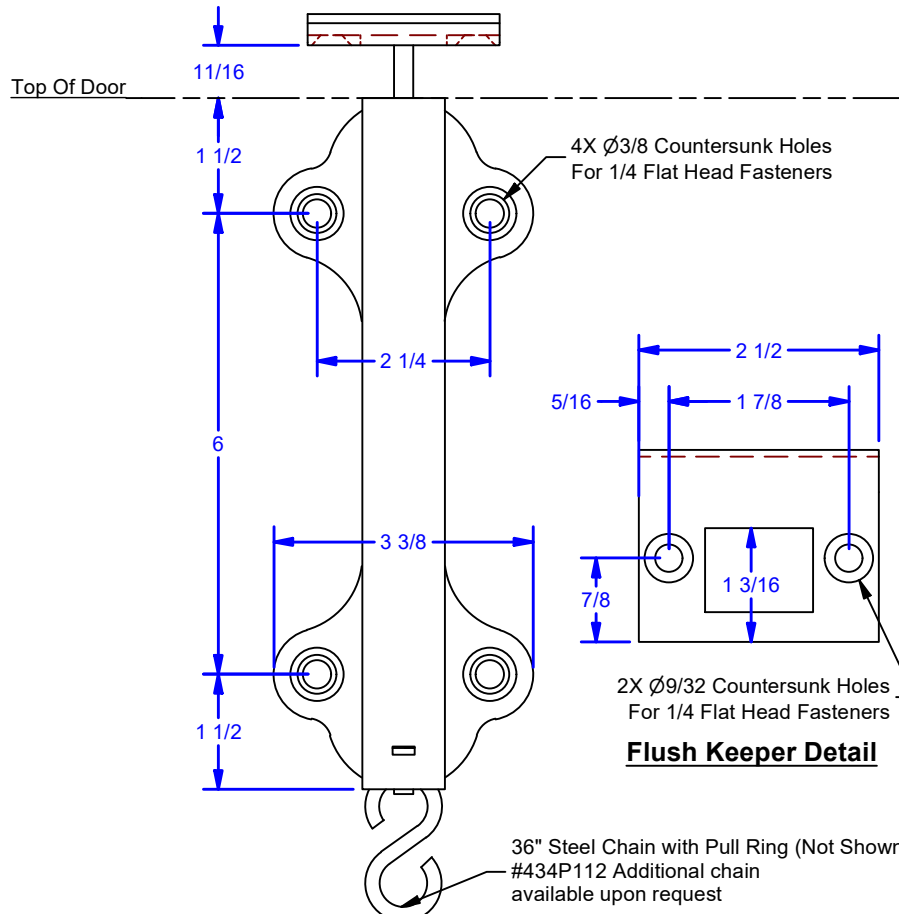

Flush Mount Keeper Configuration

Available Finishes:
 0514.00036: Powder Coat Pebble Tan
 0514.00036SC: Powder Coat Black
 0514.00036ZC: Clear Zinc Plated

*Includes:
 (6 ea.) #14 x 1-1/2" Flat Head Slotted Wood Screws, zinc
 (2 ea.) #10 x 3/4" Pan Head Phillips Sheet Metal Screw, zinc

FRONT

ALL DIMENSIONS IN INCHES

THE INFORMATION CONTAINED IN THIS DRAWING IS THE SOLE PROPERTY OF CROWN INDUSTRIAL. ANY REPRODUCTION IN PART OR AS A WHOLE WITHOUT THE WRITTEN PERMISSION OF CROWN INDUSTRIAL IS PROHIBITED.	ID #:	STOCK PART #:
	0001630	0514.00036
DESCRIPTION:		MATERIAL:
514 P36 Spring Bolt w/ Keeper		Steel
FINISH:	# PCS:	REV:



CROWN INDUSTRIAL
 So. San Francisco, Ca
 (650) 952-5150
 www.crown-industrial.com

DWG #: 514
 DRAWN:BCM 4/17/2014
 SHEET #6
 File: 0001616.idw

4

3

2

1