

Hardware Sets FOR WOOD AND METAL DOORS

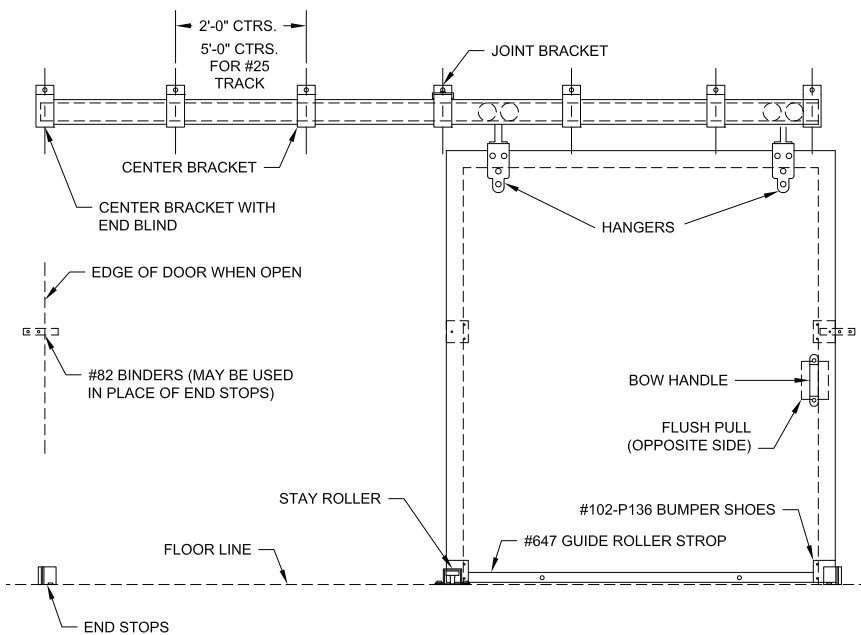

SINGLE DOOR MATERIAL LIST	
*	FT. TRACK
*	CENTER BRACKET
*	JOINT BRACKET
2	END BLINDS
1	PR. HANGERS
1	FLUSH PULL
1	BOW HANDLE
4	BUMPER SHOES
1	GUIDE ROLLER STRIP
2	END STOPS
1	STAY ROLLERS

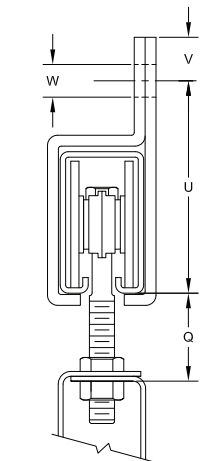

**SIDEWALL BRKT.
w/ HANGER**

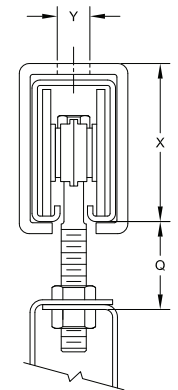

**OVERHEAD BRKT.
w/ HANGER**

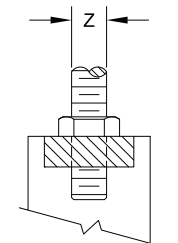

TRUCK ONLY

Single Sliding Doors

These complete sets contain the following hardware:

Quantity	Item
1	Pair Hangers.
*	Sufficient Lock-Joint track (approximately twice width of opening).
2	End Blinds.
*	Sufficient Center and Lock-Joint Track Brackets. (Spaced on approximately 2'0" centers). *†
1	Bow Handle.
1	Flush Pull.
2	Pair Bumper Shoes.
2	Floor End Stops.
1	Stay Roller.
*	Sufficient Guide Roller Strip.
*	Fasteners **

Notes:

- * Bolt hole spacing for center stop bracket shown in chart on page 4.
- † For 25 brackets, maximum center spacing is 5'0" for 2,500 lb. capacity.
- † For 25 brackets, maximum center spacing is 2'0" for 5,000 lb. capacity.
- ** Hardware sets include proper fasteners to attach the hardware to the door. Fasteners to attach the hardware to the wall and floor are excluded.

See Page 4 for Dimensions and Ordering Instructions.

Hardware Sets FOR WOOD AND METAL DOORS

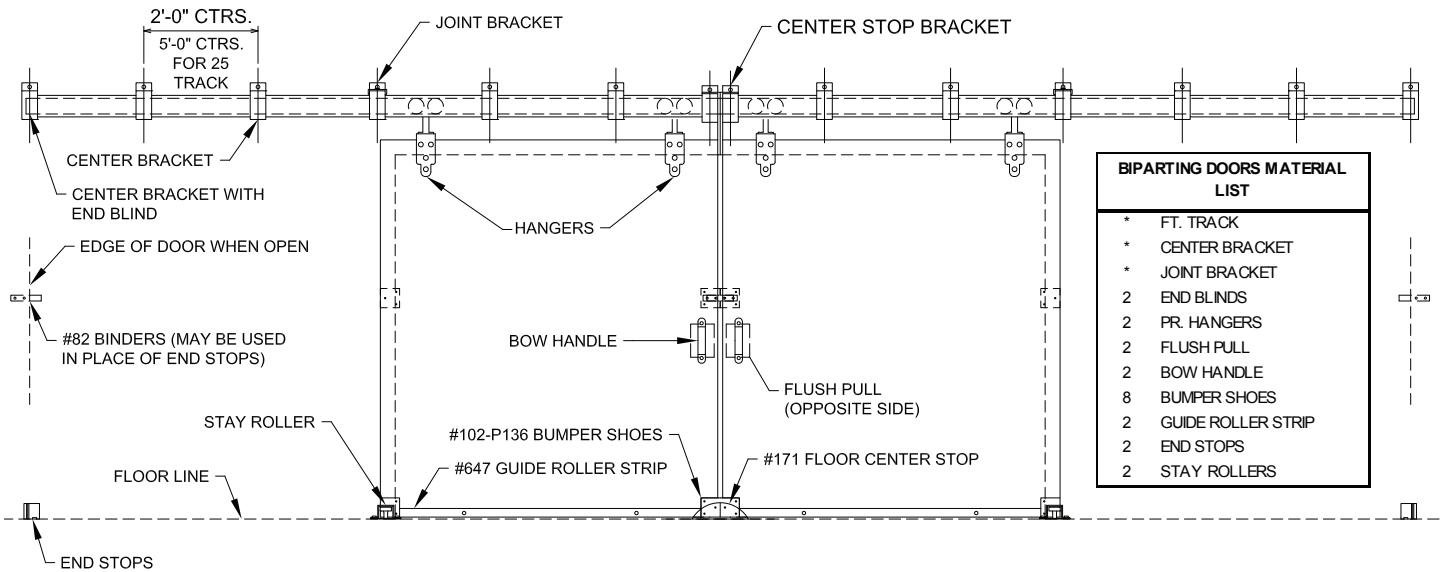

BIPARTING DOORS MATERIAL LIST	
*	FT. TRACK
*	CENTER BRACKET
*	JOINT BRACKET
2	END BLINDS
2	PR. HANGERS
2	FLUSH PULL
2	BOW HANDLE
8	BUMPER SHOES
2	GUIDE ROLLER STRIP
2	END STOPS
2	STAY ROLLERS

Bi-Parting Sliding Doors

These complete sets contain the following hardware:

Quantity	Item
2	Pair Hangers.
*	Sufficient Lock-Joint track (approximately twice width of opening).
1	Center Stop Bracket. *
2	End Blinds.
*	Sufficient Center and Lock-Joint Track Brackets. (Spaced on approximately 2'0" centers). *†
2	Bow Handle.
2	Flush Pull.
4	Pair Bumper Shoes.
2	Floor End Stops.
2	Stay Roller.
*	Sufficient Guide Roller Strip.
*	Fasteners **

Notes:

- * Bolt hole spacing for center stop bracket shown in chart on page 4.
- † For 25 brackets, maximum center spacing is 5'0" for 2,500 lb. capacity.
- † For 25 brackets, maximum center spacing is 2'0" for 5,000 lb. capacity.
- ** Hardware sets include proper fasteners to attach the hardware to the door. Fasteners to attach the hardware to the wall and floor are excluded.

See Page 4 for Dimensions and Ordering Instructions.

Box Track Type

To Select Proper Size Track See Truck and Hanger Selection Charts Pages 4, 6 and 7.

*** NOTE: #5, and #25 track are used for special applications including curves and switches. See page 20 and 21 for more information and consult with our engineers.**

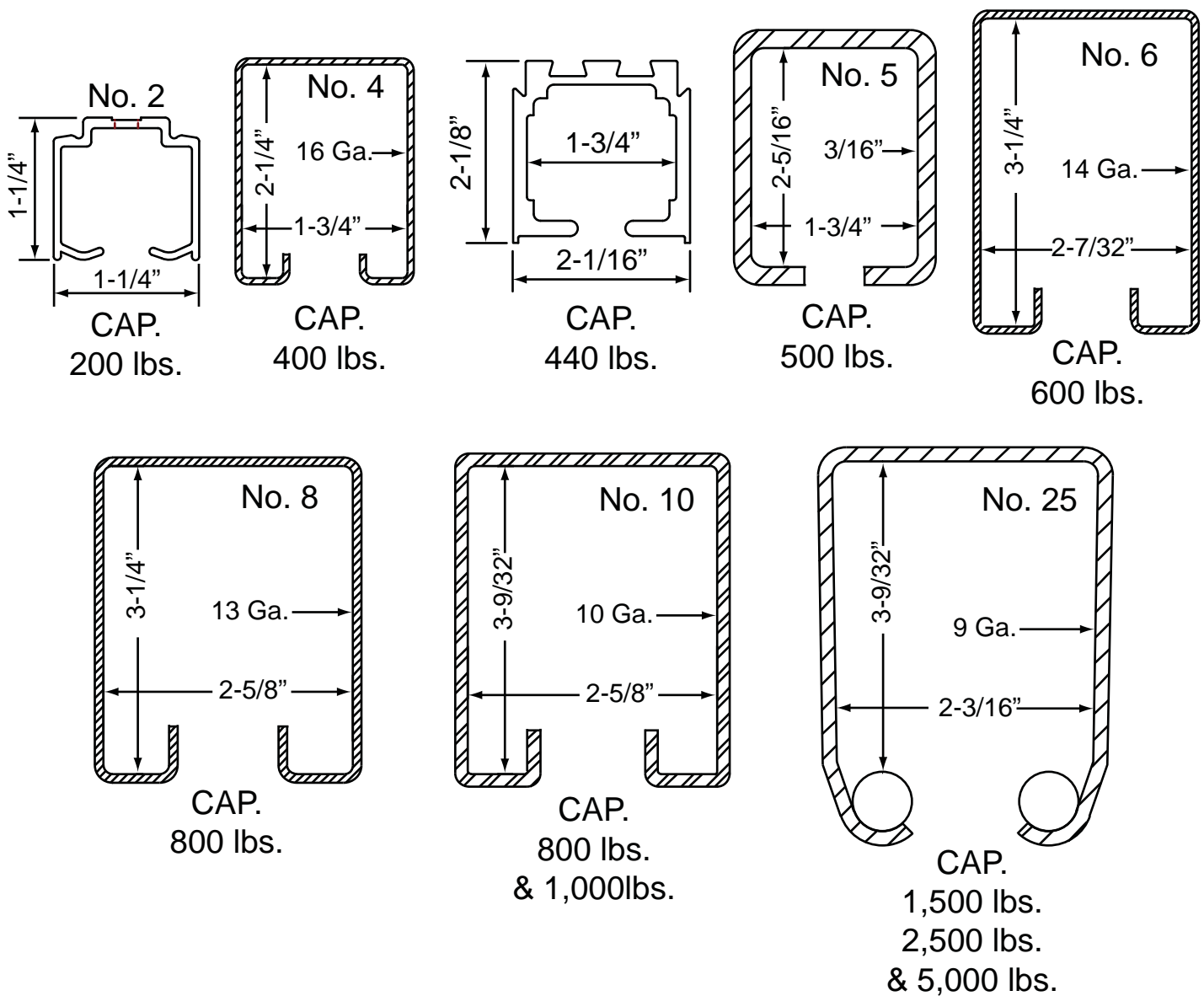

Box Track Data

*Capacity For Doors Weighing --lbs.	Track No.	Ga.	Inside Dimensions In Inches	Available Lengths Ft.	Powder Coat Paint	Galvanized Available	Aluminum Available	Stainless Steel Available	Weight Per Foot --lbs.
"Lock-Joint"® Style Track - Manually Operated Doors									
200	2	(al)	1-3/16" Wide 1-1/8" High	6', 8', 10' & 12'		x	x	x	1/2
400	4	16	1-3/4" Wide 2-1/4" High	6', 8', 10' & 12'	x	x		x	1-3/4
500	5	7	1-3/4" Wide 2-5/16" High	10'	x	x		x	5
600	6	14	2-7/32" Wide 3-1/4" High	6', 8', & 10'	x	x		x	2-3/4
800	8	13	2-5/8" Wide 3-1/4" High	6', 8', & 10'	x				4
1000	10	10	2-5/8" Wide 3-1/4" High	6', 8', & 10'	x	x			5-3/4
**1500	25	9	2-13/16" Wide 3-9/32" High	6', 8', & 10'	x	x		x	8
†2500	25	9	2-13/16" Wide 3-9/32" High	6', 8', & 10'	x	x		x	8
††5000	25	9	2-13/16" Wide 3-9/32" High	6', 8', & 10'	x	x		x	8
"Lock-Joint"® Style Track - Power Operated Doors									
800	10	10	2-5/8" Wide 3-1/4" High	6', 8', & 10'	x	x			5-3/4
**1500	25	9	2-13/16" Wide 3-9/32" High	6', 8', & 10'	x	x		x	8
†2500	25	9	2-13/16" Wide 3-9/32" High	6', 8', & 10'	x	x		x	8
††5000	25	9	2-13/16" Wide 3-9/32" High	6', 8', & 10'	x	x		x	8

*With pair of hangers per door.

**1,500 lb. Capacity when #25 track is used with #25-1BLE hanger.

†2,500 lb. Capacity when #25 track is used with #25-1BSE hanger.

††5,000 lb. Capacity when #25 track is used with #25-TBSE hanger.

***Note: #5 and #25 track are used for special applications including curves & switches. See pages 20 and 21 for more information and consult with our engineers.**

Door Hanger Data

*Capacity for Doors Weighing -Lbs.	Door Thickness	Hanger Number	Track Number	Type Aprons	Type Bearing	Page Number
"LOCK-JOINT" STYLE TRACK - MANUALLY OPERATED						
200	3/4" to 1-3/4"	2-1P	2	n/a	Polymer	9
400	1-1/2" to 2-1/4"	4Z2P	4	Zinc Plate	Polymer	9
400	1-1/2" to 2-1/4"	4Z2R	4	Zinc Plate	Roller	9
400	up to 1-3/4"	4Z-F	4	Zinc Plate	Ball	10
500	1-3/4" to 2-1/4"	5P-1975	5	Painted	Ball	20
600	1-3/4" to 2-1/4"	6P2R	6	Painted	Roller	10
600	1-3/4" to 2-1/4"	6Z3R	6	Zinc Plate	Roller	10
600	2-1/4" to 3"	6P4R	6	Painted	Roller	10
600	2-1/4" to 3"	6Z5R	6	Zinc Plate	Roller	10
600	1-3/4" to 2-1/4"	6P2B	6	Painted	Ball	10
600	1-3/4" to 2-1/4"	6Z3B	6	Zinc Plate	Ball	10
600	2-1/4" to 3"	6P4B	6	Painted	Ball	10
600	2-1/4" to 3"	6Z5B	6	Zinc Plate	Ball	10
800	1-3/4" to 2-1/4"	8P2R	8	Painted	Roller	11
800	2-1/4" to 3"	8P4R	8	Painted	Roller	11
800	1-3/4" to 2-1/4"	8P2B	8	Painted	Ball	11
800	2-1/4" to 3"	8P4B	8	Painted	Ball	11
1000	1-3/4" to 2-1/4"	8P2R	10	Painted	Roller	11
1000	1-3/4" to 2-1/4"	8Z3R	10	Zinc Plate	Roller	11
1000	2-1/4" to 3"	8P4R	10	Painted	Roller	11
1000	2-1/4" to 3"	8Z5R	10	Zinc Plate	Roller	11
1000	1-3/4" to 2-1/4"	8P2B	10	Painted	Ball	11
1000	1-3/4" to 2-1/4"	8Z3B	10	Zinc Plate	Ball	11
1000	2-1/4" to 3"	8P4B	10	Painted	Ball	11
1000	2-1/4" to 3"	8Z5B	10	Zinc Plate	Ball	11
1500	1-3/4" to 2-1/2"	25P2BLE	25	Painted	Ball	12
1500	2-1/4" to 3"	25P4BLE	25	Painted	Ball	12
2500	2-1/4" to 2-3/4"	25P2BSE	25	Painted	Ball	12
"LOCK-JOINT" STYLE TRACK - POWER OPERATED						
800	1-3/4" to 2-1/4"	10P2BE	10	Painted	Ball	12
800	2-1/4" to 3"	10P4BE	10	Painted	Ball	12
1500	1-3/4" to 2-1/2"	25P2BLE	25	Painted	Ball	12
1500	2-1/4" to 3"	25P4BLE	25	Painted	Ball	12
2500	2-1/4" to 3-3/4"	25P2BSE	25	Painted	Ball	12
*With Pair of Hangers per Door						
*NOTE: #5 and #25 track are used for special applications including curves and switches. See page 20 & 21 for more information and consult with our engineers.						

Trucks (less aprons)

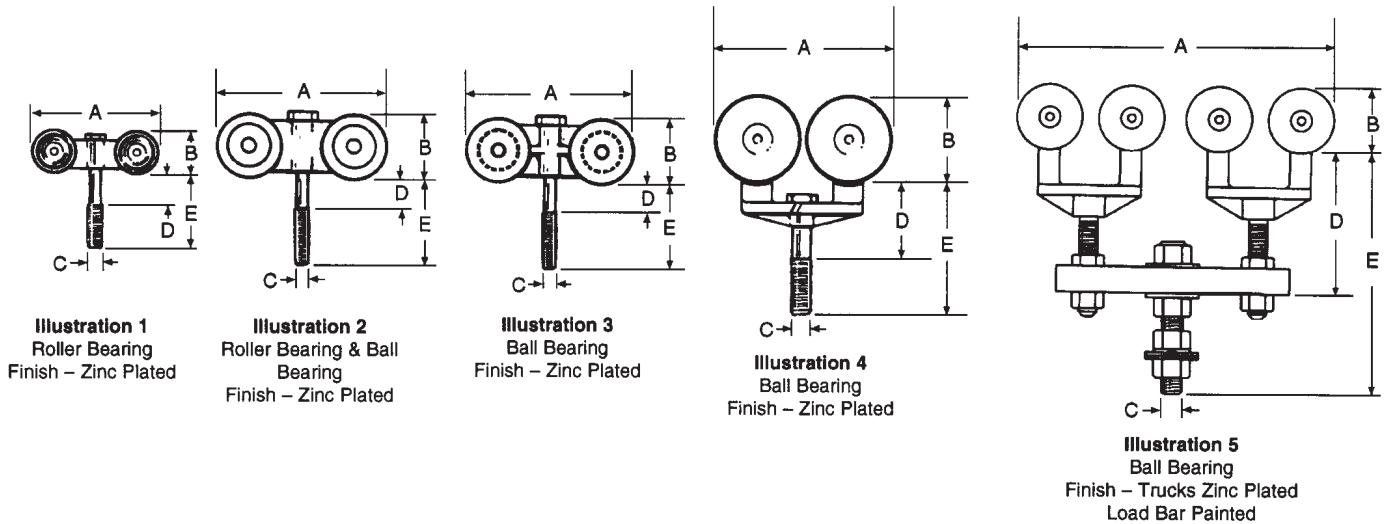

TRUCKS FOR MANUALLY OPERATED DOORS

For Door Weight (lbs.)	Cat. No.	For Track No.	Ills. No.	Dimensions					Hanger Page #	Weight Per Pair
				A	B	C	D	E		
200	2-1P	2	1**	1-11/16"	7/8"	8mm	0	1-1/4"	9	5 oz.
400	4-1P	4	1***†	4-3/4"	2-1/8"	1/2"-13	11/16"	2-7/8"	9	2 lb.
400	4-1R	4	1†	4-3/4"	2-1/8"	1/2"-13	5/8"	2-13/16"	9	2-1/2 lb.
500	5B	5	n/a	2-1/8"	2-1/8"	5/8"-11	1-5/8"	4-5/8"	20	3 lb.
600	6-1R	6	2	7-1/2"	3"	3/4"-10	1/2"	3-5/8"	10	7-1/4 lb.
600	6-1B	6	2	7-1/2"	3"	3/4"-10	1/2"	3-5/8"	10	7-1/4 lb.
800	8-1R	8	2	7-1/2"	3"	3/4"-10	1/2"	3-5/8"	11	8 lb.
800	8-1B	8	2	7-1/2"	3"	3/4"-10	1/2"	3-5/8"	11	8 lb.
1000	8-1R	10	2	7-1/2"	3"	3/4"-10	1/2"	3-5/8"	11	8 lb.
1000	8-1B	10	2	7-1/2"	3"	3/4"-10	1/2"	3-5/8"	11	8 lb.

TRUCKS FOR POWERED OR MANUALLY OPERATED DOORS

For Door Weight (lbs.)	Cat. No.	For Track No.	Ills. No.	Dimensions					Hanger Page #	Weight Per Pair
				A	B	C	D	E		
800	10-1BE	10	3	7-1/4"	2-3/4"	3/4"-10	3/4"	3-7/8"	12	5 oz.
1500	25-1BLE	25	3	7-1/2"	3"	3/4"-10	1-1/16"	4-1/4"	12, 21	2 lb.
2500	25-1BSE	25	4	7"	3"	7/8"-9	3-1/2"	8"	12, 21	2-1/2 lb.
5000	25-TBSE	25	5	15"	3"	1"-8	7"	11-1/4"	12, 21	3 lb.

* With Pair of Trucks Per Door.

**See Illustration 1, polymer bearings only

† See Page 9 for wood door top plate option.

*Note: #5, and #25 track can be used for special applications including curves and switches. See page 20 and 21 for more information and consult with our engineers.

No. 4 Hangers (cont.)

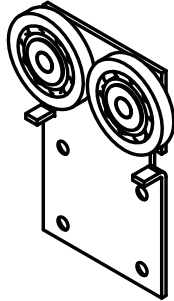
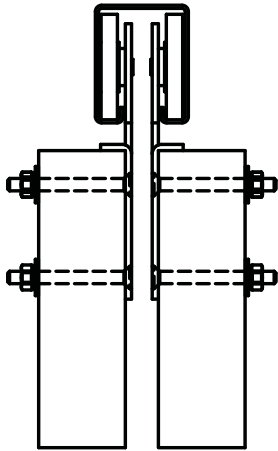

No. 4Z-F HANGER

Use: For manually operated sliding doors mounted in parallel (bi-passing) in a **single run of #4 box track**.

For doors no thicker than 1-3/4", weighing up to **150 lbs ea.**

One Style: 4Z-F

Head Clearance: Distance top of door to bottom of track: 9/16".

Bottom of track to center of hole in sidewall bracket: 3-3/4".

Construction: 2-1/8" diameter steel wheels. *Ball bearings.* Apron: 1/8" thick, 3-3/8" wide, and 3" tall.

Finish: Zinc plated apron.

Packed: Boxed, with bolts.

Weight: 3-1/2 lbs. per pair.

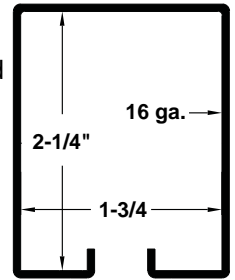

No. 4
400lb capacity

No. 6 Hangers (trucks with aprons)

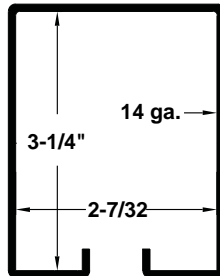

No. 6
600lb capacity



No. 6R HANGER

Use: For manually operated sliding doors 1-3/4" to 3" thick weighing up to **600 lbs.**

Two Sizes: 6P2R for doors 1-3/4" to 2-1/4" (Painted Aprons); 6Z3R for doors 1-3/4" to 2-1/4" (Zinc Aprons) 6P4R doors 2-1/4" to 3" (Painted Aprons); 6Z5R for doors 2-1/4" to 3" (Zinc Aprons).

Head Clearance: Distance top of door to bottom of track; minimum 1-1/8", maximum 2-3/4". Bottom of track to center of hole in sidewall bracket; 6-1/4".

Construction: 3" diameter steel wheels. *Caged roller bearings.* Lateral and vertical adjustment. Apron: 9/64" thick 4" wide 7-1/2" long.

Finish: Zinc plated trucks. Aprons painted or zinc.

Packed: Boxed, with bolts.

Weight: 12-1/4 lbs. per pair.

No. 6B HANGER

Use: For manually operated sliding doors 1-3/4" to 3" thick weighing up to **600 lbs.**

Two Sizes: 6P2B for doors 1-3/4" to 2-1/4" (Painted Aprons); 6Z3B for doors 1-3/4" to 2-1/4" (Zinc Aprons) 6P4B doors 2-1/4" to 3" (Painted Aprons); 6Z5B for doors 2-1/4" to 3" (Zinc Aprons).

Head Clearance: Distance top of door to bottom of track; minimum 1-1/8", maximum 2-3/4". Bottom of track to center of hole in sidewall bracket; 6-1/4".

Construction: 3" diameter steel wheels. *Ball bearings.* Lateral and vertical adjustment. Apron: 9/64" thick 4" wide 7-1/2" long.

Finish: Zinc plated trucks. Aprons painted or zinc.

Packed: Boxed, with bolts.

Weight: 12-1/4 lbs. per pair.

Box Type Track and Brackets Installation and Functions

The unique design of Track and Brackets prevents the horizontal creep of tracks while binding them together tightly against the bottom of the bracket, achieving a smooth tight joint for the hanger runway.

CENTER BRACKET

Slide track through center brackets. Provides support of track and track lips at required support intervals.

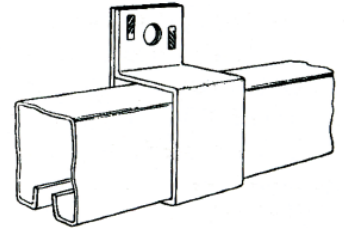

LOCK JOINT BRACKET

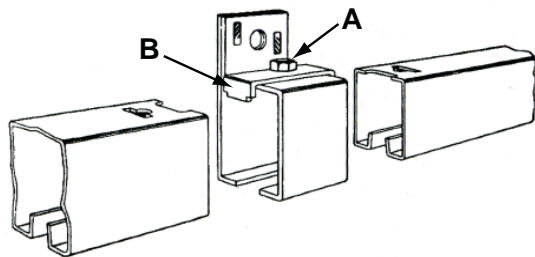

Loosen nut "A", raise clamp "B", slide tracks into bracket, drop bent ends of clamp "B" into holes in tops of track and tighten nut "A". Provides the unique feature between track sections.

NOTE: #25 Track joints must be welded on all manual applications over 2500 lbs. and for all powered applications. See page 19 for welding kit information.

END BLIND

Push end blind into center sidewall/overhead track bracket. Slide the assembled bracket and end blind onto the end of track. The end blind acts as a stop to prevent creep on one-piece track applications as well as closes off the end of the track to birds, etc.

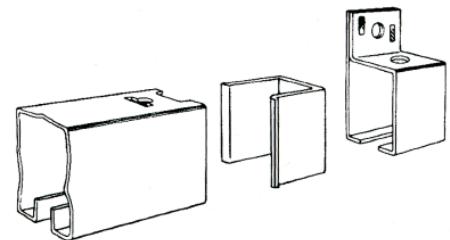

CENTER STOP BRACKETS

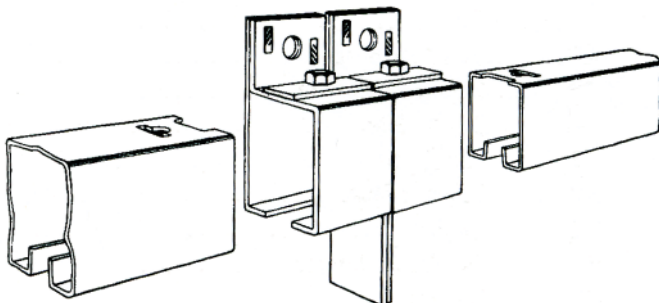

Slide each end of each track fully into center stop bracket. Provides track support and door stop at center of bi-parting door installations.

Brackets for No. 6 Track

SIDEWALL

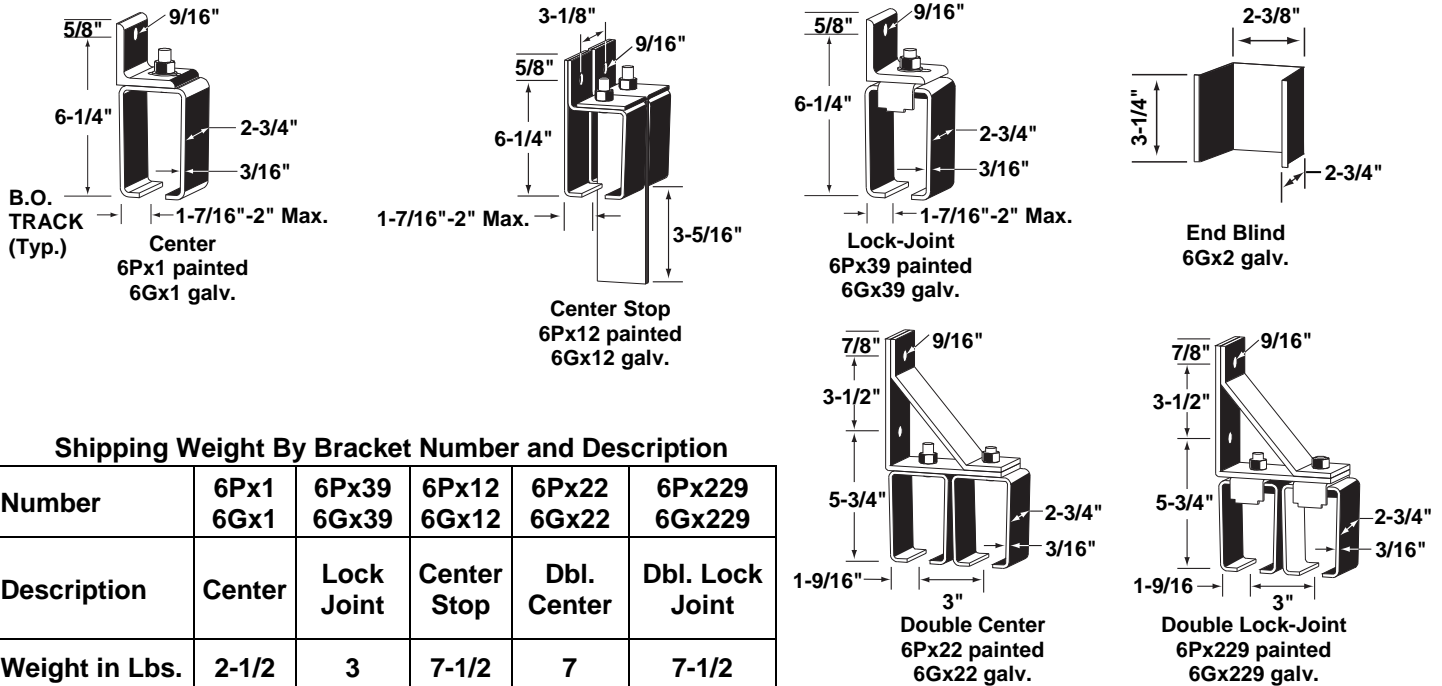

OVERHEAD

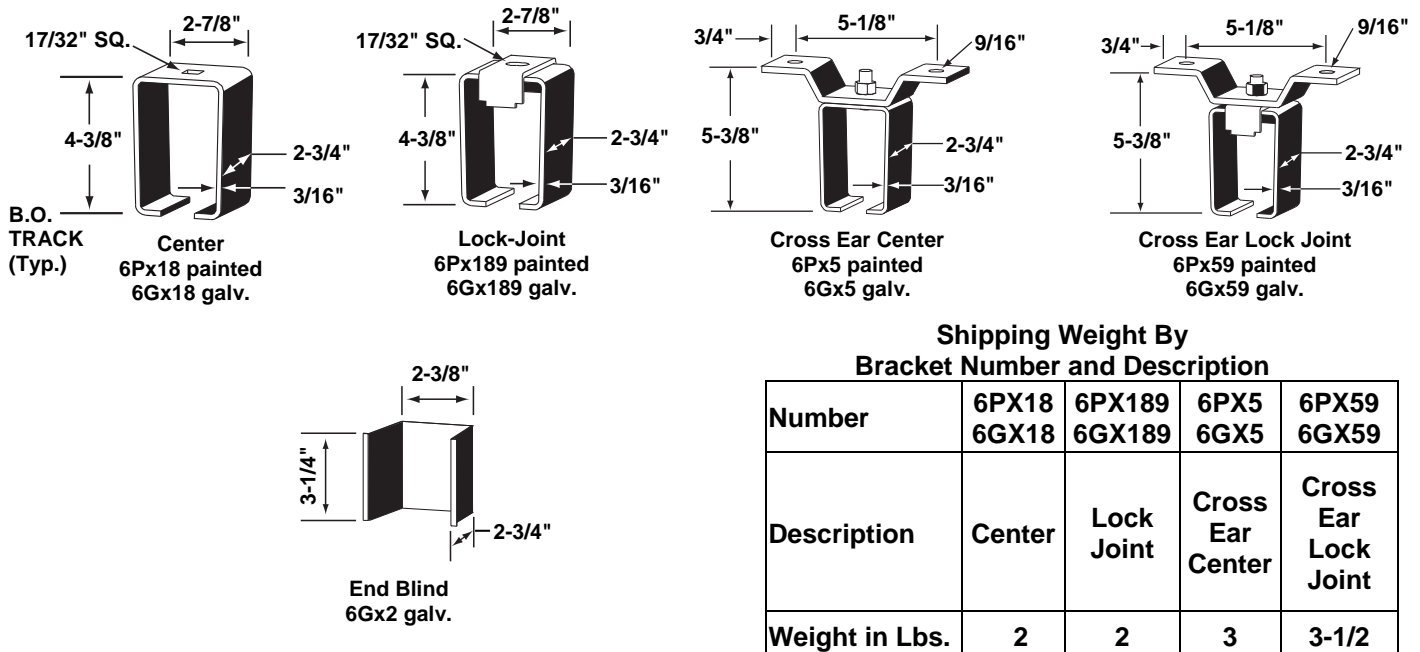

NOTE: MAX. BRACKET SPACING 24" ON CENTERS. Tracks extend into center stop and end brackets 2-3/4".
*Use end blind in combination with any center bracket to produce an end bracket.

WARRANTY

Hardware products are warranted to be of good quality, and free from defects in material and workmanship under normal intended use for a period of one (1) year from the date of purchase. If any hardware, or part thereof, is determined by the factory not to be as warranted, the factory will, at its option and without charge, replace the defective part or parts.

Under no circumstances shall we be liable for indirect or consequential damages of any kind. These warranties are in lieu of all other warranties expressed or implied including, but not limited to, warranties of merchantability or fitness for a particular purpose. The warranties cover Crown Industrial material. We shall not be liable, nor do we assume responsibility for damage or operational failures caused by supporting and/or surrounding structure and/or equipment, overloading of the product beyond the manufacturer's rated capacity, improper use or application beyond the manufacturer's intended or recommended use, or other external causes such as abuse or acts of god and other causes beyond our control. Maintenance and adjustments are the responsibility of the owner. This guarantee does not cover such maintenance and adjustments, nor any services which may be required as a result of the purchaser's failure to perform normal maintenance and adjustments to the purchased product.

Replacement of defective material shall be furnished without charge, delivered, installation not included. If the factory decides to service a warranted product at the purchaser's place of business and determines that no defective material or improper workmanship exists, then the purchaser shall reimburse the factory for all expenses, including time and travel, incurred in providing the service.

This guarantee is not applicable to other non-hardware products.

RETURN GOODS POLICY

Requests in writing for RGA must be made to the Crown Industrial Customer Support Department within 30 days of the material shipment from Crown Industrial. Crown will determine the eligibility to return any material and will notify the requestor within 5 day upon receipt of written request. Crown will also instruct the requestor to return the material to Crown or dispose of such before the issuance of the appropriate credit. Special items (i.e. stainless steel or custom painted) and items not manufactured by Crown (purchased) will not be eligible for return. Any material returned to Crown or disposed of without the proper authorization by Crown will be refused and no credit will be issued. Return goods must be shipped freight prepaid at the requestor's expense within 15 days of receipt of written authorization. The requestor must determine the carrier. All material returned must be received in original packaging. Credit will be given on returned material only after receipt and inspection by Crown. Provide the RGA number and a copy of the original packing slip with all returned material. Credit for all authorized returns are subject to a 25% restocking charge on the net acceptable material value.

Distributor



**C R O W N
INDUSTRIAL**

213 Michelle Court
So. San Francisco, CA 94080-6202

Phone: (650) 952-5150

Fax: (650) 873-1495

Website: www.crown-industrial.com

HDW-10

© 2012 Crown Industrial. Printed in U.S.A.

REVISIONS			
REV.	DESCRIPTION	DATE	APPROVED

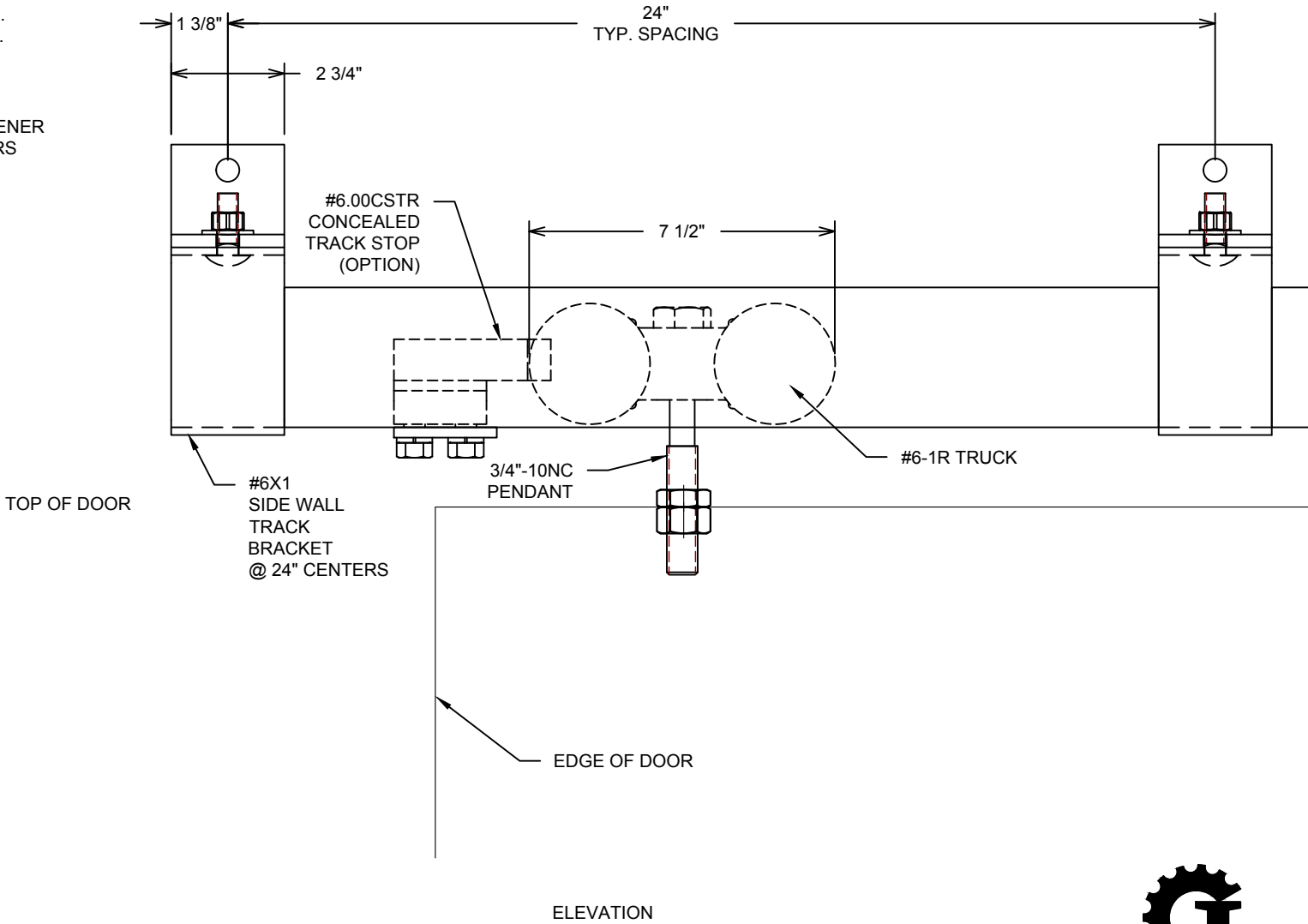
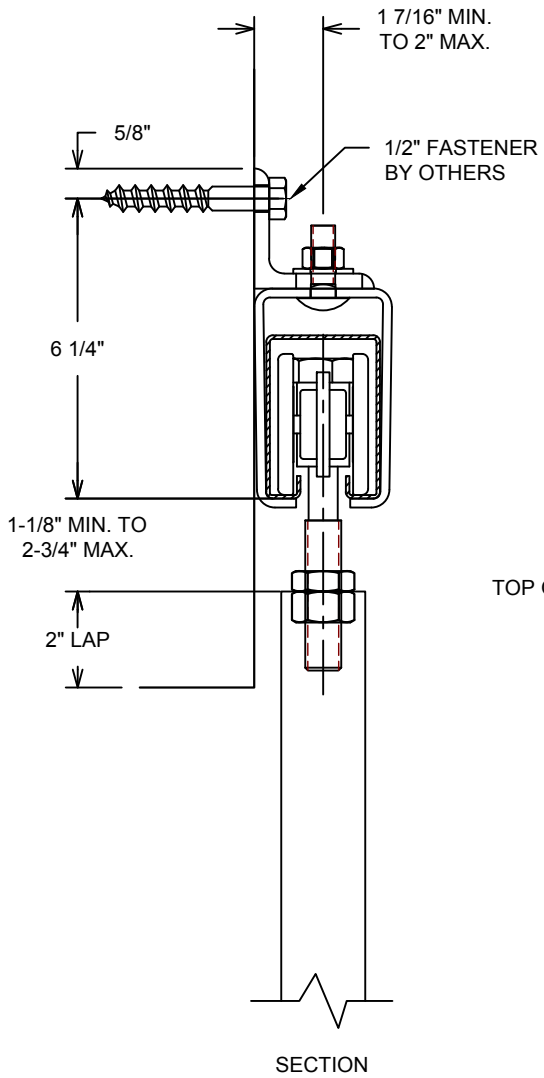

DWG #6-WRM
 DESCRIP: #6 HARDWARE 600# CAP.
 DRAWN:WRM 10/25/10 REV:
 SCALE: 3" = 1'-0"
 SHEET #6-1RX1
 FILE:j:\crown work\mtdwg6

THE INFORMATION CONTAINED IN THIS DRAWING IS THE SOLE PROPERTY OF CROWN INDUSTRIAL. ANY REPRODUCTION IN PART OR AS A WHOLE WITHOUT WRITTEN PERMISSION OF CROWN INDUSTRIAL IS PROHIBITED.



CROWN
 INDUSTRIAL
 SUPPLY
 SO. SAN FRANCISCO, CA
 (650)952-5150

REVISIONS			
REV.	DESCRIPTION	DATE	APPROVED

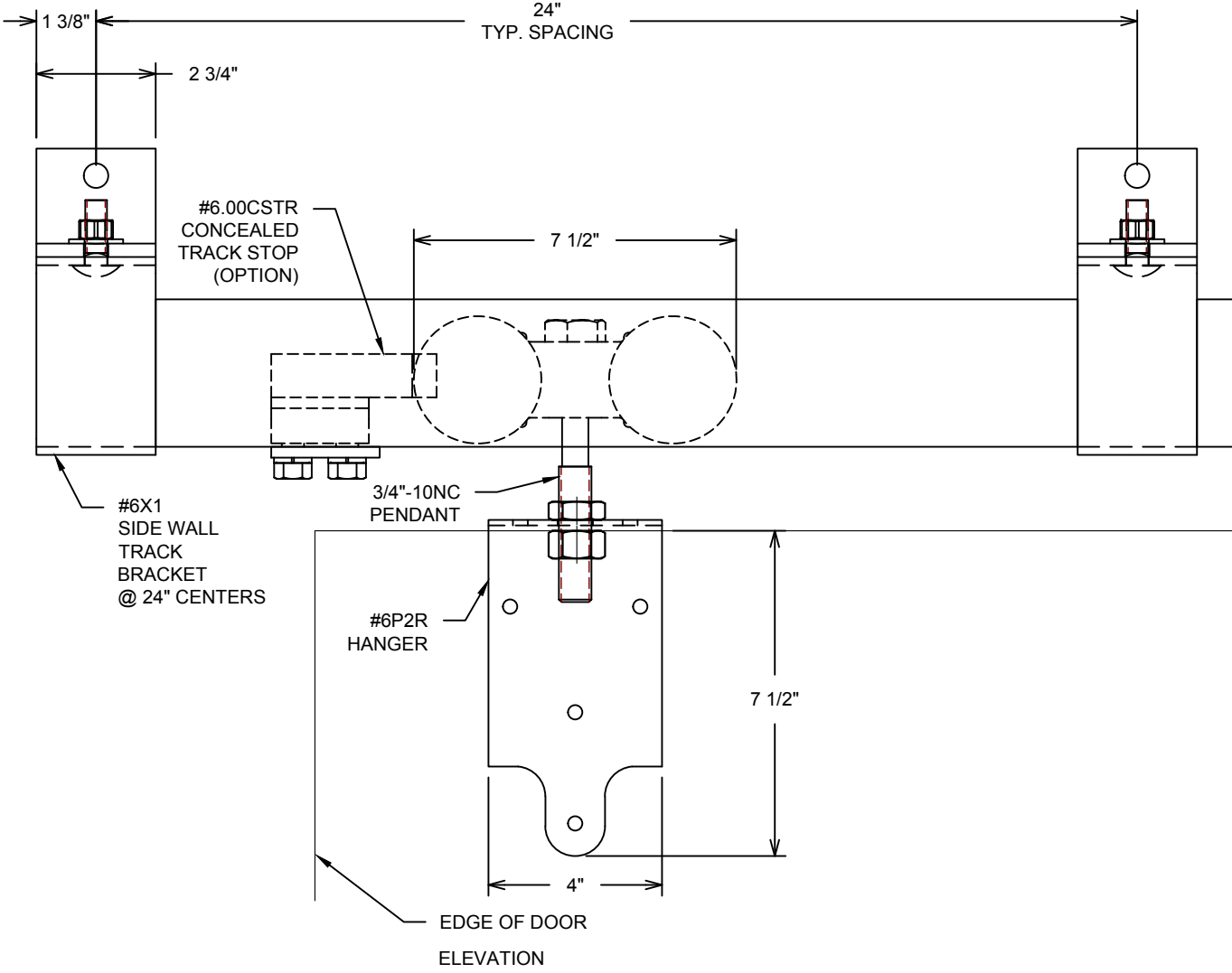
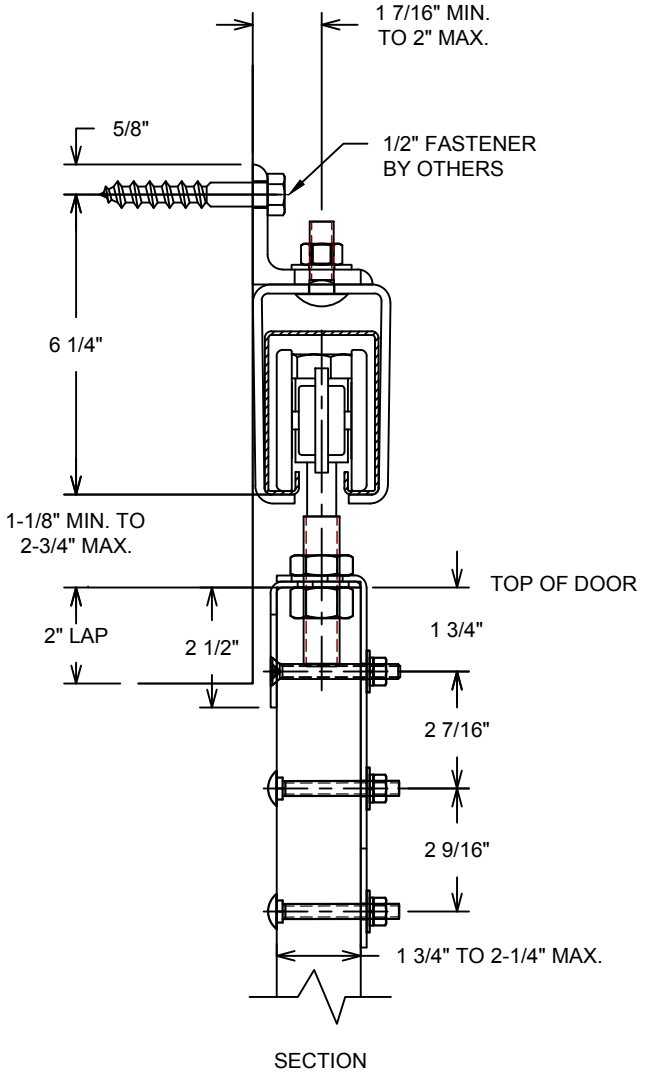

DWG #6-WRM
 DESCRIP: #6 HARDWARE 600# CAP.
 DRAWN:WRM 10/25/10 REV:
 SCALE: 3" = 1'-0"
 SHEET #6P2RX1
 FILE:j:\crown work\m\dwg\6

THE INFORMATION CONTAINED IN THIS DRAWING IS THE SOLE PROPERTY OF CROWN INDUSTRIAL. ANY REPRODUCTION IN PART OR AS A WHOLE WITHOUT WRITTEN PERMISSION OF CROWN INDUSTRIAL IS PROHIBITED.



CROWN
INDUSTRIAL
SUPPLY
 SO. SAN FRANCISCO, CA
 (650)952-5150

REVISIONS			
REV.	DESCRIPTION	DATE	APPROVED

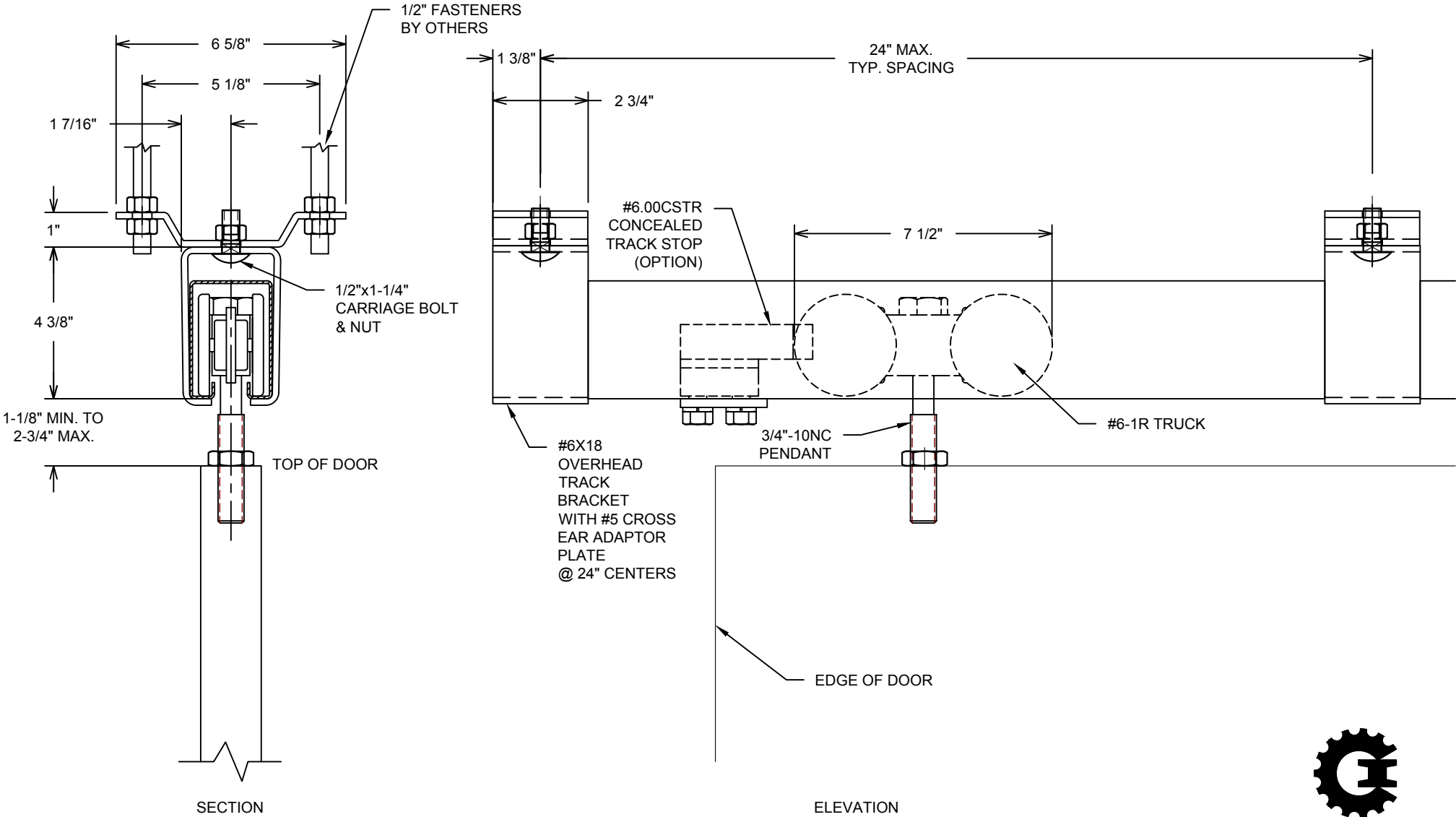

DWG #6-WRM
 DESCRIP: #6 HARDWARE 600# CAP.
 DRAWN:WRM 10/25/10 REV:
 SCALE: 3" = 1'-0"
 SHEET #6-1RX5
 FILE:j:\crown work\mtdwg6

THE INFORMATION CONTAINED IN THIS DRAWING IS THE SOLE PROPERTY OF CROWN INDUSTRIAL. ANY REPRODUCTION IN PART OR AS A WHOLE WITHOUT WRITTEN PERMISSION OF CROWN INDUSTRIAL IS PROHIBITED.



CROWN
INDUSTRIAL
SUPPLY
 SO. SAN FRANCISCO, CA
 (650)952-5150

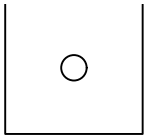

REVISIONS			
REV.	DESCRIPTION	DATE	APPROVED

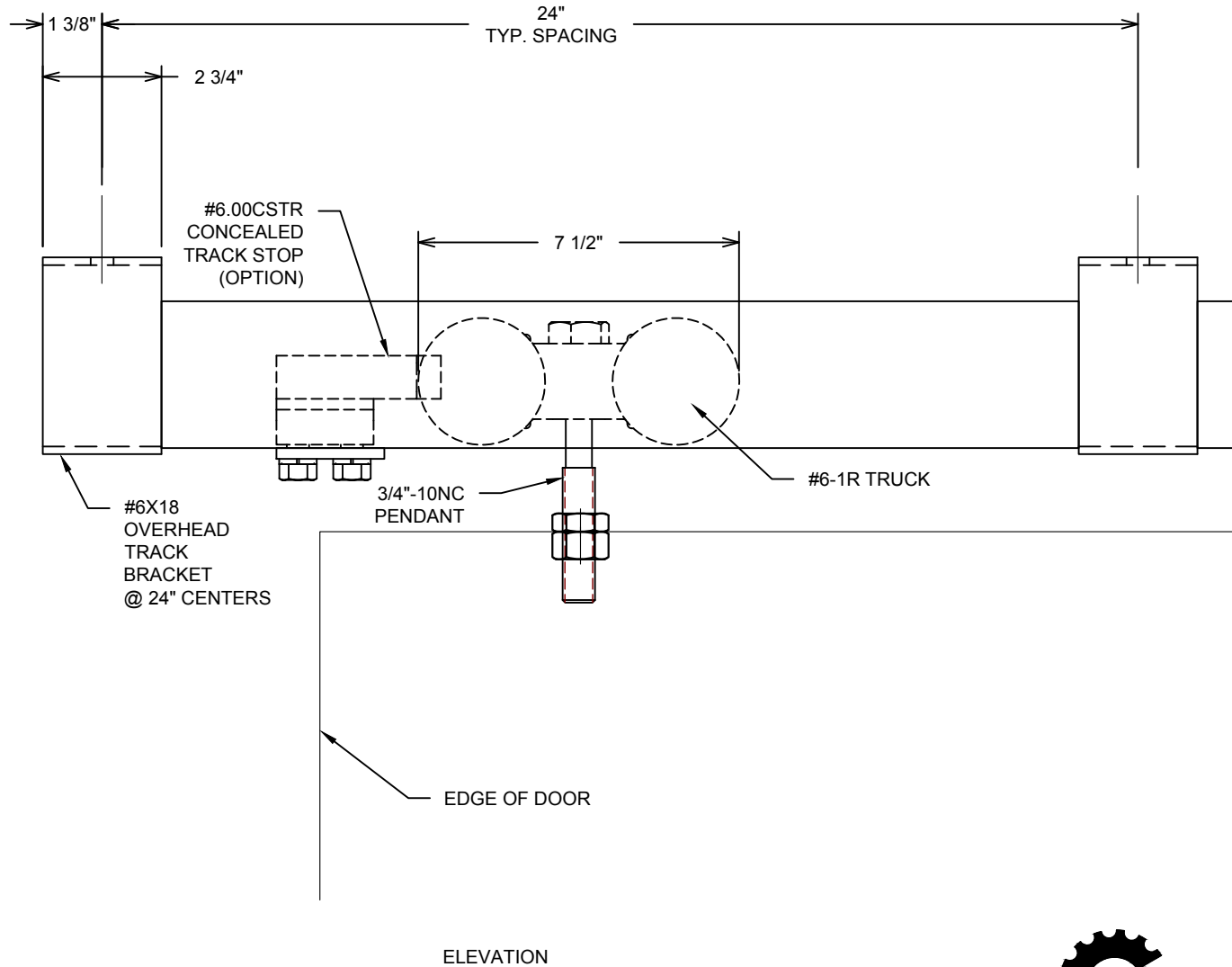
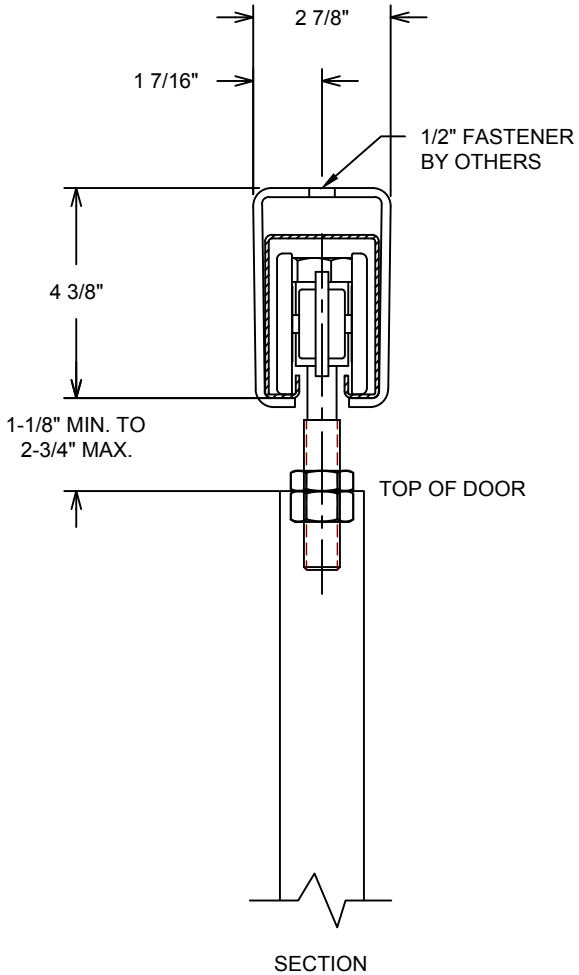

DWG #6-WRM
 DESCRIP: #6 HARDWARE 600# CAP.
 DRAWN:WRM 10/25/10 REV:
 SCALE: 3" = 1'-0"
 SHEET #6-1RX18
 FILE:j:\crown work\mtdwg6

THE INFORMATION CONTAINED IN THIS DRAWING IS THE SOLE PROPERTY OF CROWN INDUSTRIAL. ANY REPRODUCTION IN PART OR AS A WHOLE WITHOUT WRITTEN PERMISSION OF CROWN INDUSTRIAL IS PROHIBITED.



CROWN
 INDUSTRIAL
 SUPPLY

SO. SAN FRANCISCO, CA
 (650)952-5150

REVISIONS			
REV.	DESCRIPTION	DATE	APPROVED

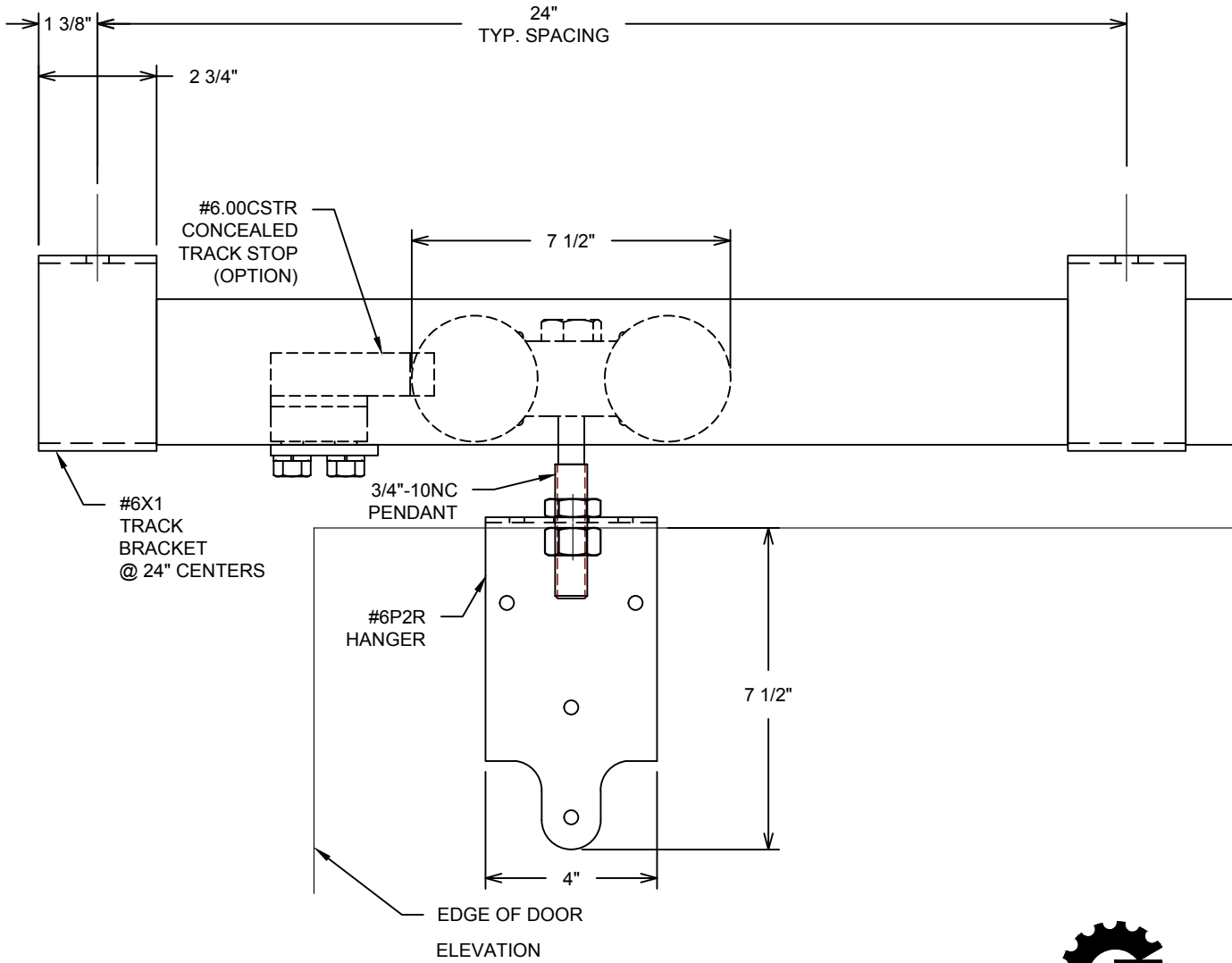
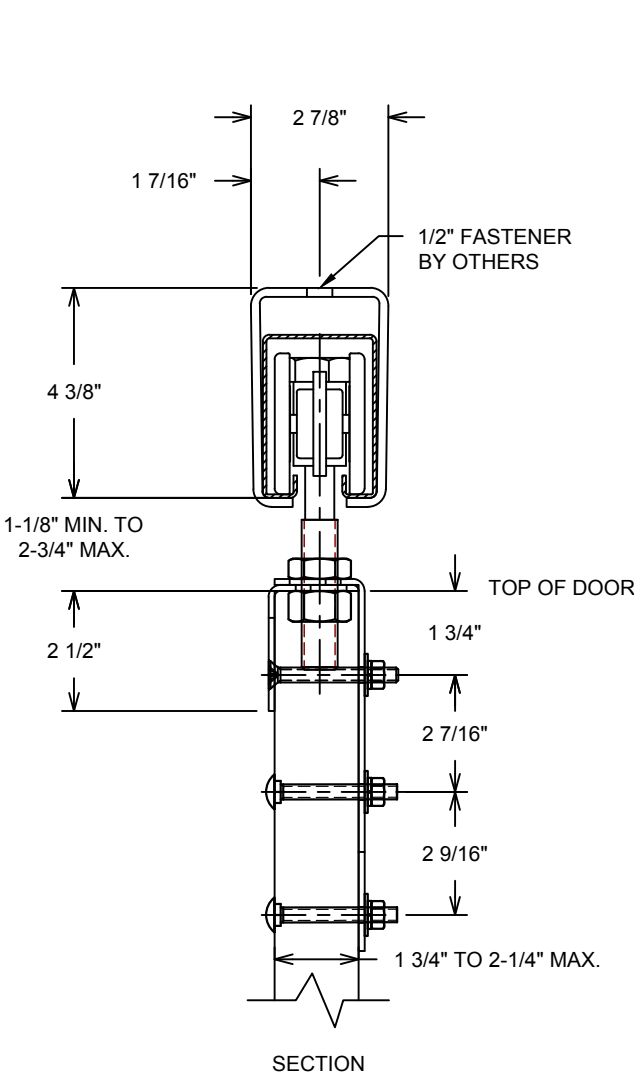

DWG #6-WRM
 DESCRIP: #6 HARDWARE 600# CAP.
 DRAWN:WRM 10/25/10 REV:
 SCALE: 3" = 1'-0"
 SHEET #6P2RX18
 FILE:j:\crown work\m\dwg\6

THE INFORMATION CONTAINED IN THIS DRAWING IS THE SOLE PROPERTY OF CROWN INDUSTRIAL. ANY REPRODUCTION IN PART OR AS A WHOLE WITHOUT WRITTEN PERMISSION OF CROWN INDUSTRIAL IS PROHIBITED.



CROWN
INDUSTRIAL
SUPPLY
 SO. SAN FRANCISCO, CA
 (650)952-5150

REVISIONS			
REV.	DESCRIPTION	DATE	APPROVED

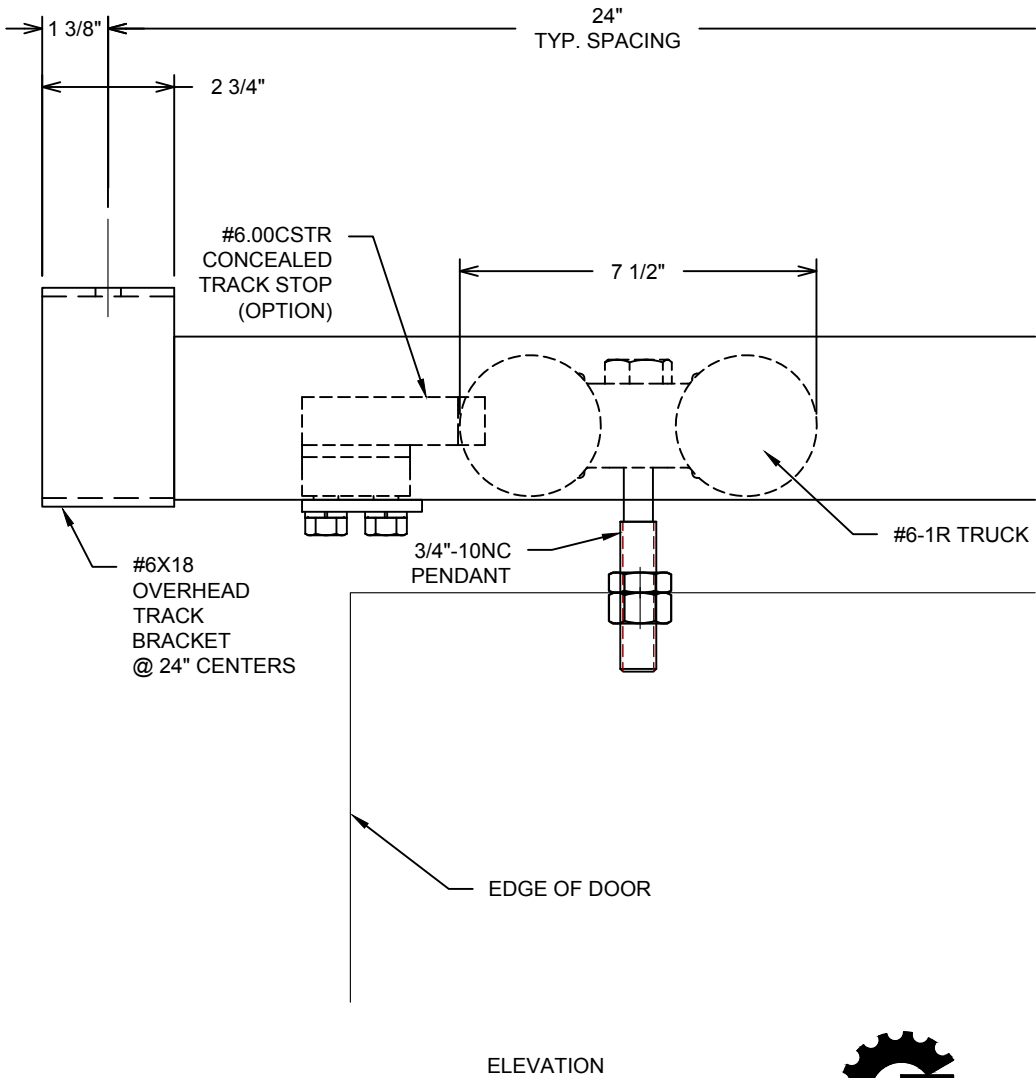
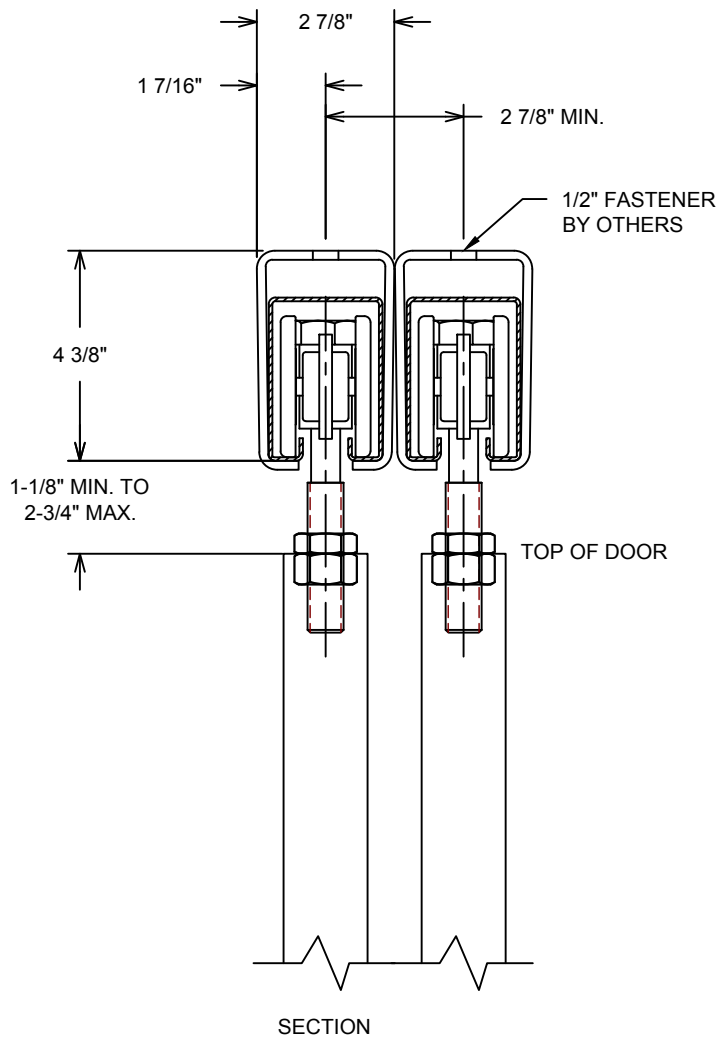

DWG #6-WRM
 DESCIP: #6 HARDWARE 600# CAP.
 DRAWN:WRM 10/25/10 REV:
 SCALE: 3" = 1'-0"
 SHEET #6-1RX18 DOUBLE
 FILE:j:\crown work\mtdwg6

THE INFORMATION CONTAINED IN THIS DRAWING IS THE SOLE PROPERTY OF CROWN INDUSTRIAL. ANY REPRODUCTION IN PART OR AS A WHOLE WITHOUT WRITTEN PERMISSION OF CROWN INDUSTRIAL IS PROHIBITED.



CROWN
INDUSTRIAL
SUPPLY
 SO. SAN FRANCISCO, CA
 (650)952-5150

REVISIONS			
REV.	DESCRIPTION	DATE	APPROVED

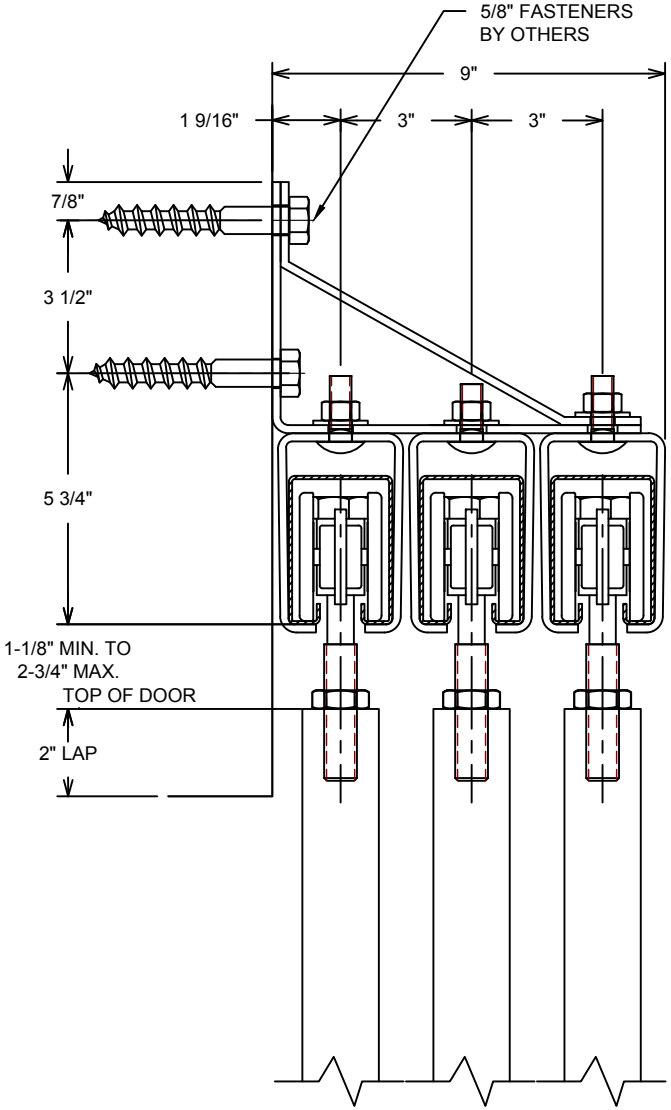

SECTION

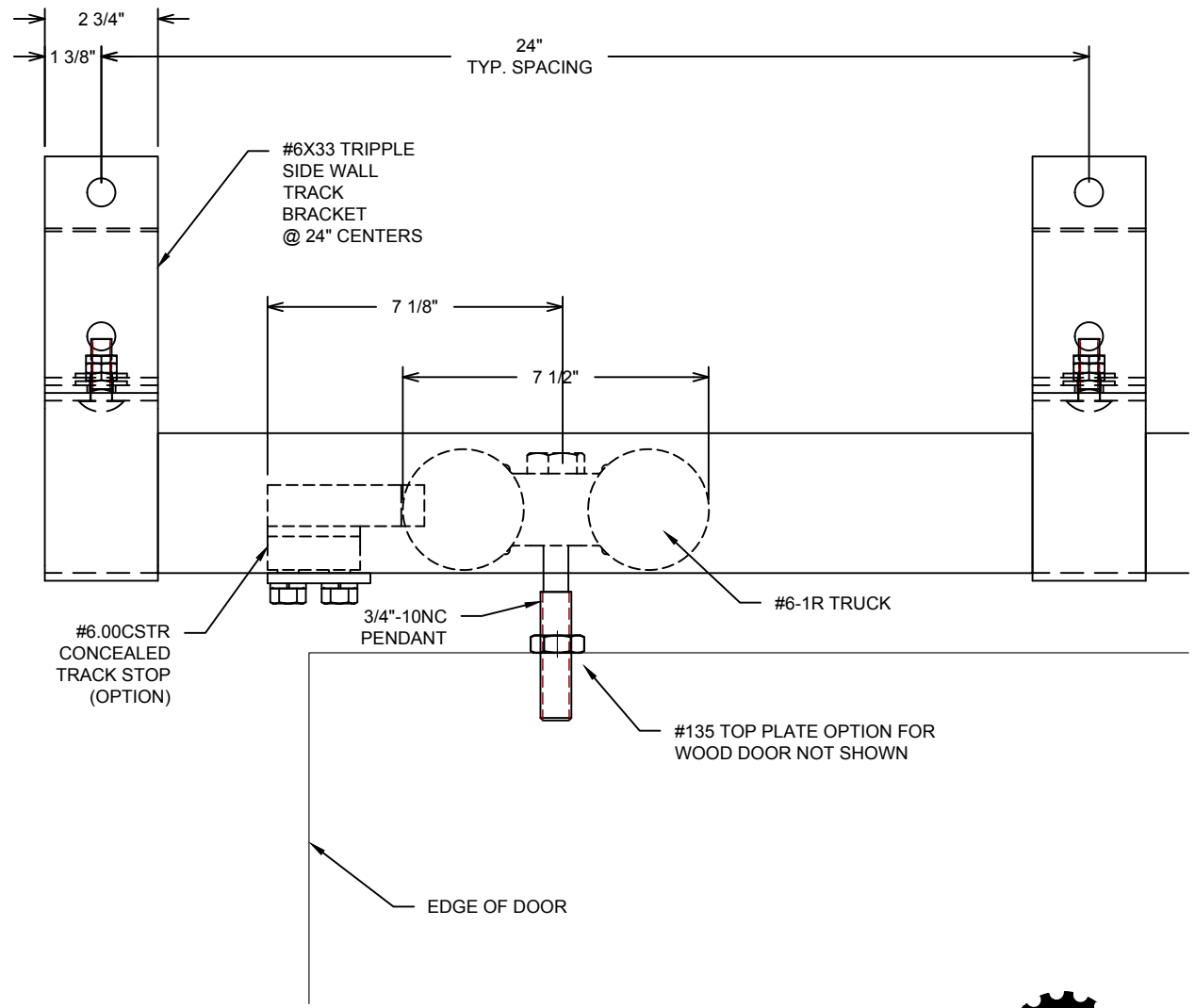

ELEVATION

DWG #6-WRM
 DESCRIP: #6 HARDWARE 600# CAP.
 DRAWN:WRM 9/18/12 REV:
 SCALE: 2 187/256" = 1'-0"
 SHEET #6-1RX33
 FILE:j:\crown work\mtdwgj6

THE INFORMATION CONTAINED IN THIS DRAWING IS THE SOLE PROPERTY OF CROWN INDUSTRIAL. ANY REPRODUCTION IN PART OR AS A WHOLE WITHOUT WRITTEN PERMISSION OF CROWN INDUSTRIAL IS PROHIBITED.



CROWN
 INDUSTRIAL
 SUPPLY

SO. SAN FRANCISCO, CA
 (650)952-5150

REVISIONS			
REV.	DESCRIPTION	DATE	APPROVED

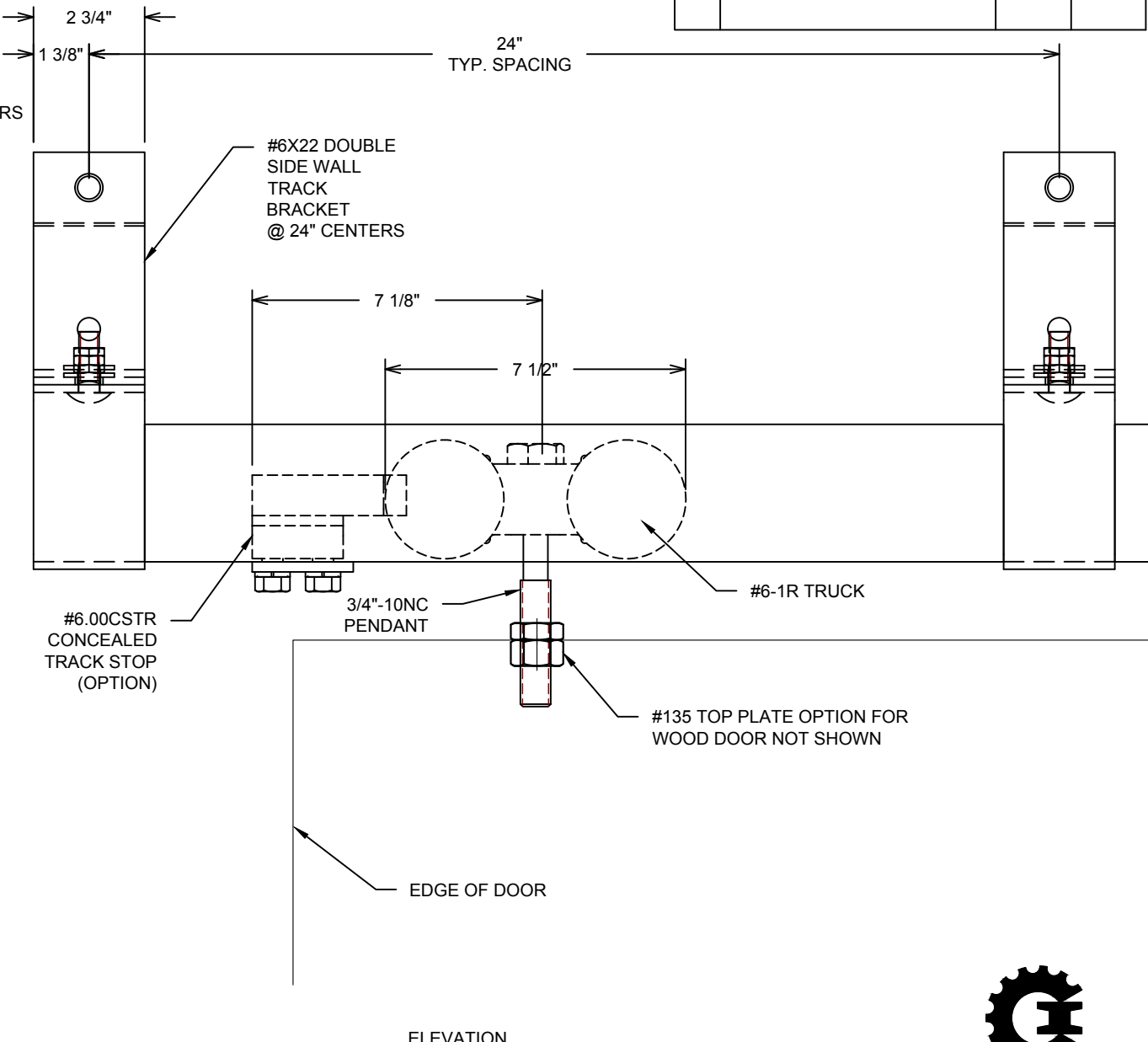
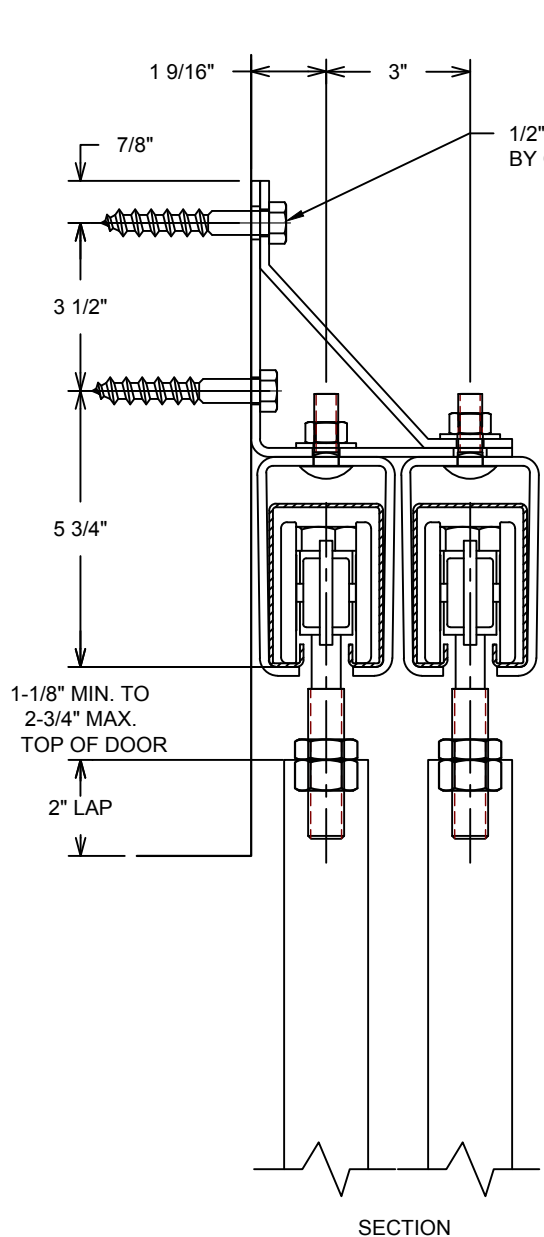

DWG #6-WRM
 DESCRIP: #6 HARDWARE 600# CAP.
 DRAWN:WRM 10/25/10 REV:
 SCALE: 3" = 1'-0"
 SHEET #6-1RX22
 FILE:j:\crown work\mtdwgj6

THE INFORMATION CONTAINED IN THIS DRAWING IS THE SOLE PROPERTY OF CROWN INDUSTRIAL. ANY REPRODUCTION IN PART OR AS A WHOLE WITHOUT WRITTEN PERMISSION OF CROWN INDUSTRIAL IS PROHIBITED.



CROWN
INDUSTRIAL
SUPPLY
 SO. SAN FRANCISCO, CA
 (650)952-5150

REVISIONS			
REV.	DESCRIPTION	DATE	APPROVED

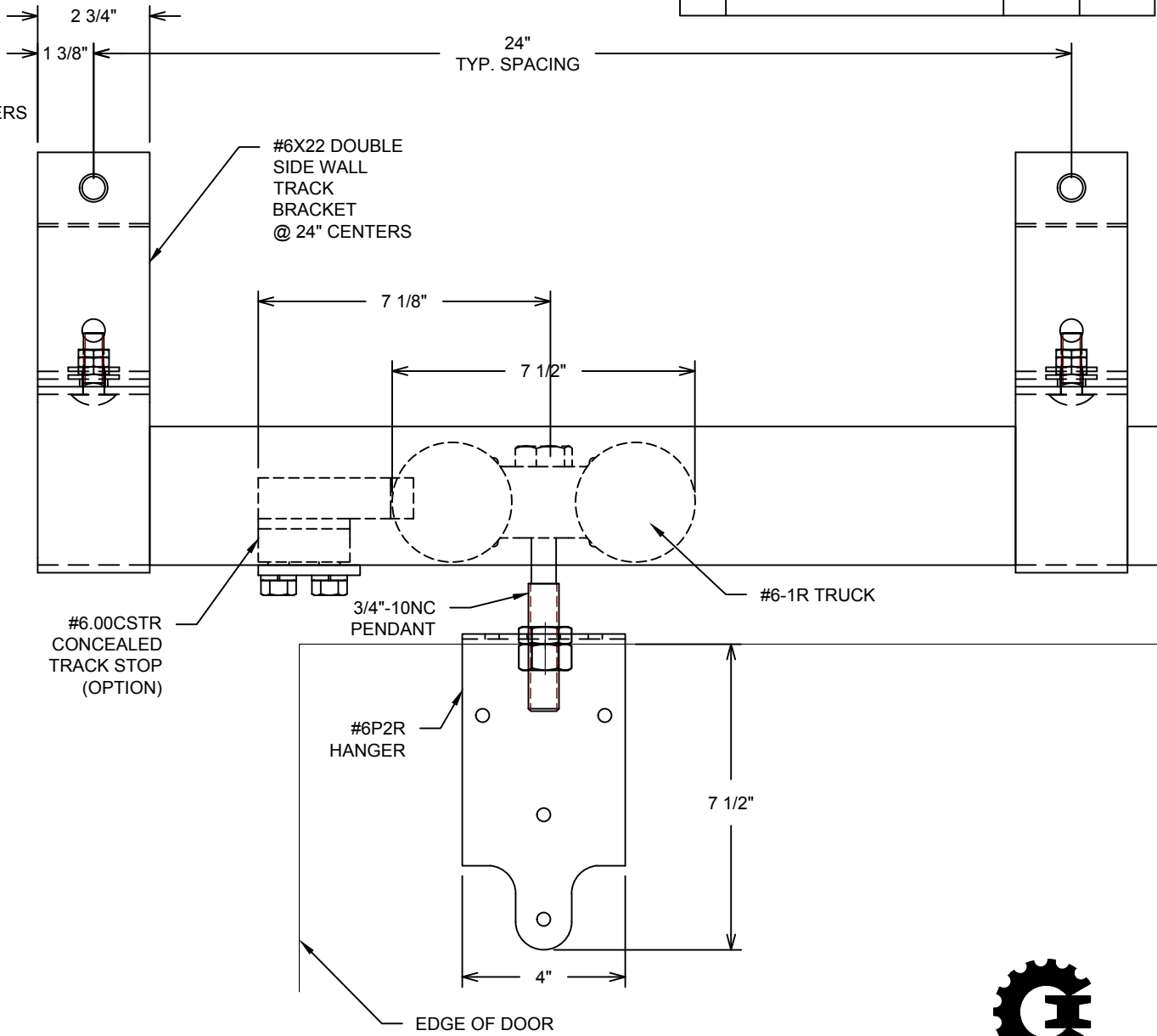
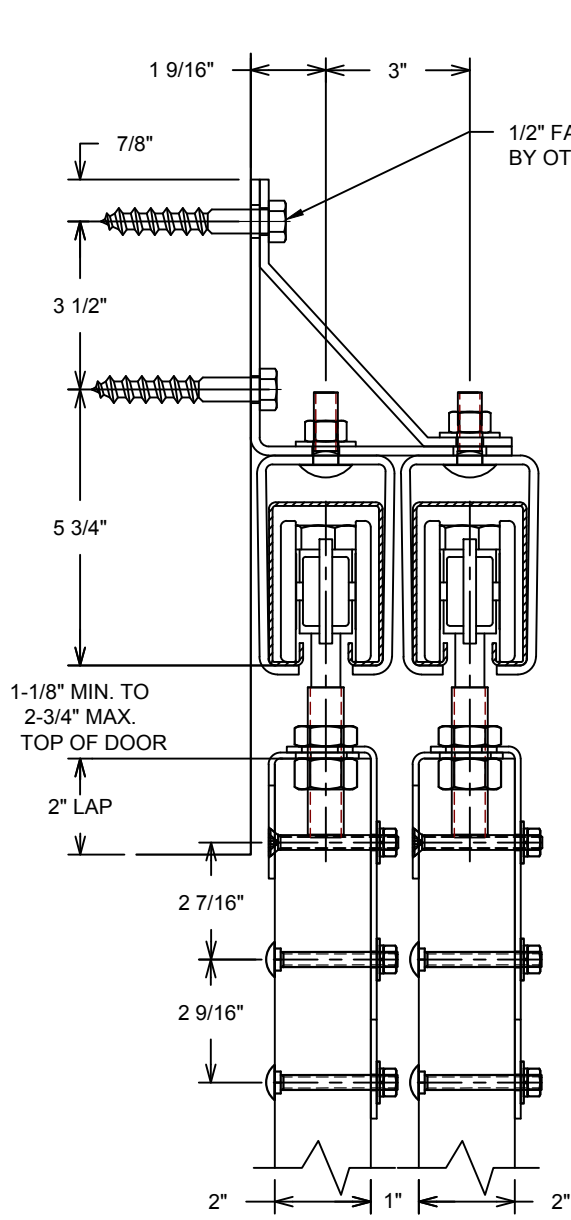

DWG #6-WRM
 DESCRIP: #6 HARDWARE 600# CAP.
 DRAWN:WRM 10/25/10 REV:
 SCALE: 3" = 1'-0"
 SHEET #6-1RX22
 FILE:j:\crown work\mtdwgj6

THE INFORMATION CONTAINED IN THIS DRAWING IS THE SOLE PROPERTY OF CROWN INDUSTRIAL. ANY REPRODUCTION IN PART OR AS A WHOLE WITHOUT WRITTEN PERMISSION OF CROWN INDUSTRIAL IS PROHIBITED.



CROWN
INDUSTRIAL
SUPPLY
 SO. SAN FRANCISCO, CA
 (650)952-5150

REVISIONS			
REV.	DESCRIPTION	DATE	APPROVED

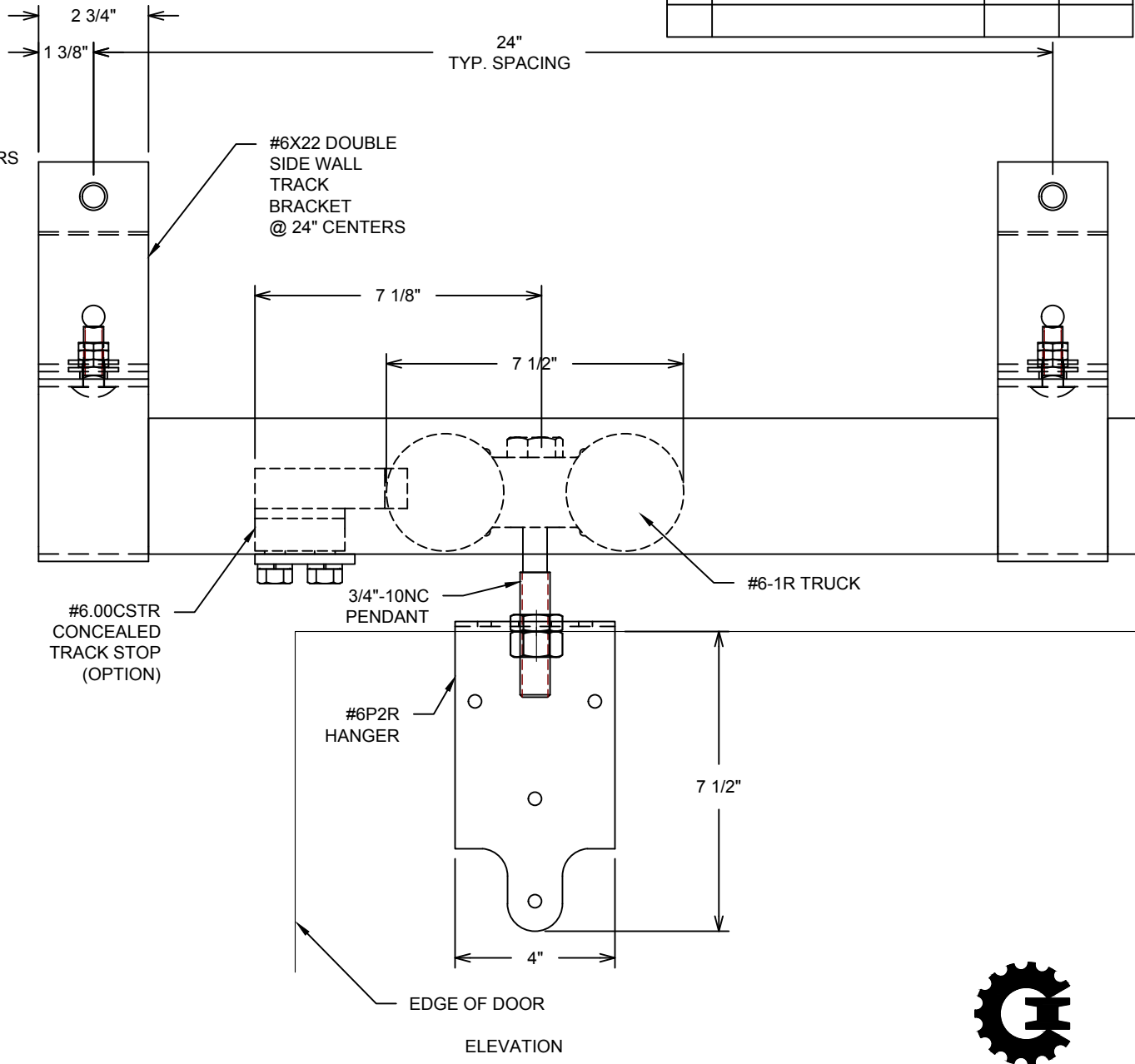
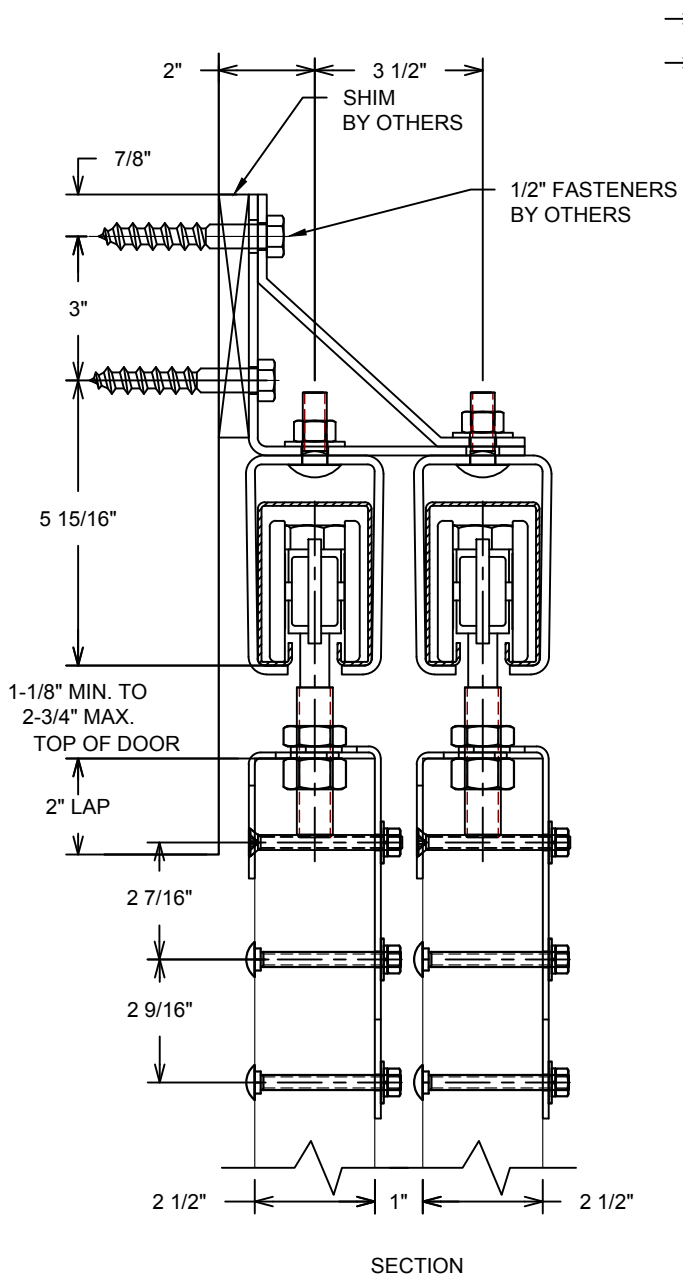

DWG #6-WRM
 DESCRIP: #6 HARDWARE 600# CAP.SPL
 DRAWN:WRM 10/25/10 REV:
 SCALE: 3" = 1'-0"
 SHEET #6-1RX22
 FILE:j:\crown work\m\dwg\6

THE INFORMATION CONTAINED IN THIS DRAWING IS THE SOLE PROPERTY OF CROWN INDUSTRIAL. ANY REPRODUCTION IN PART OR AS A WHOLE WITHOUT WRITTEN PERMISSION OF CROWN INDUSTRIAL IS PROHIBITED.



CROWN
 INDUSTRIAL
 SUPPLY
 SO. SAN FRANCISCO, CA
 (650)952-5150