

CRS14

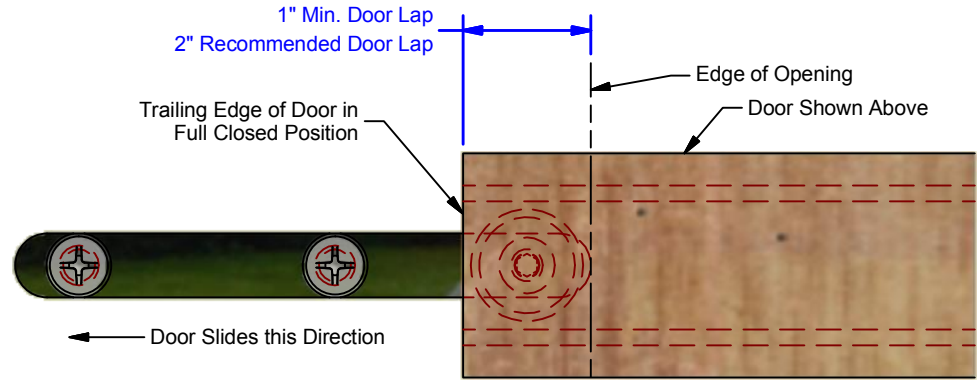

PLAN VIEW

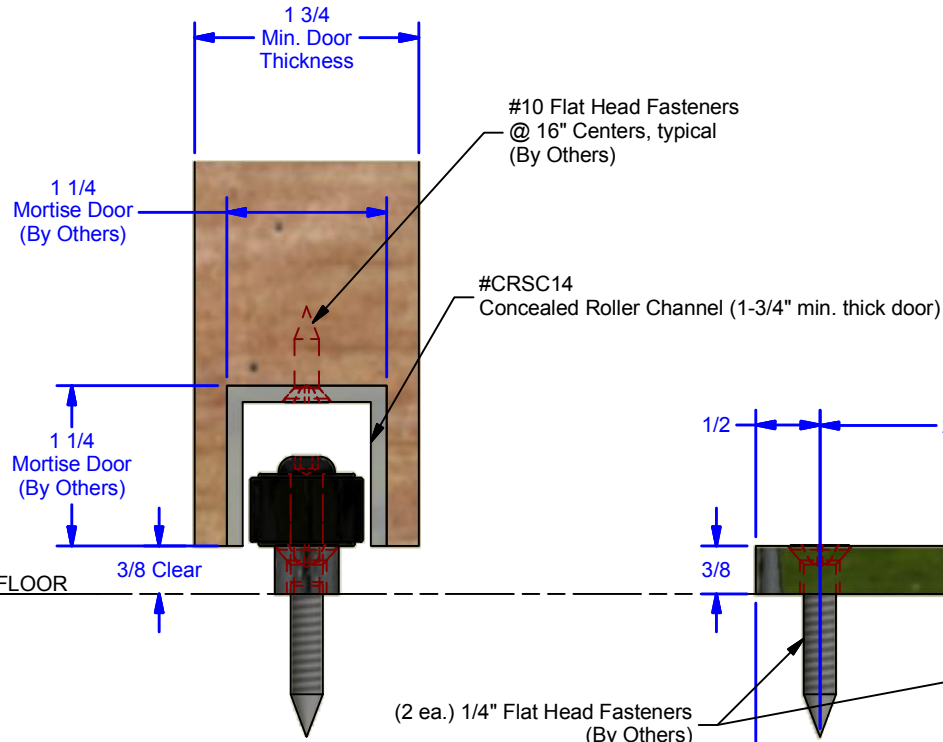

END VIEW

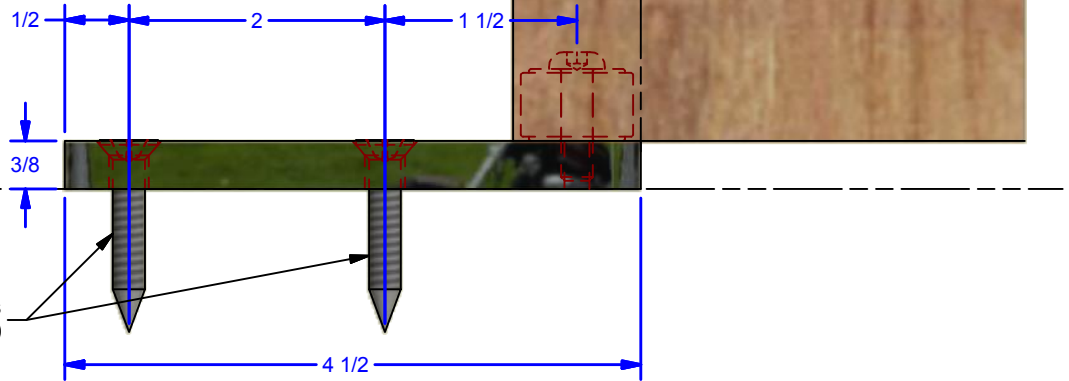

ELEVATION VIEW

- Available Finishes:**
 CRS14-Z: Clear Zinc w. Black Oxide Wheel
 CRS14-BZ: Black Zinc w. Black Oxide Wheel
 CRS14-S: 304 Stainless Steel w. #4 Brushed Finish w. Black Oxide Wheel
 CRS14-S-S: 304 Stainless Steel w. #4 Brushed Finish w. Stainless Steel Wheel.

DWG #: 0000504
 DRAWN: BCM 3/10/2015
 SHEET #3
 File: 0000504.idw

ALL DIMENSIONS IN INCHES

THE INFORMATION CONTAINED IN THIS DRAWING IS THE SOLE PROPERTY OF CROWN INDUSTRIAL. ANY REPRODUCTION IN PART OR AS A WHOLE WITHOUT THE WRITTEN PERMISSION OF CROWN INDUSTRIAL IS PROHIBITED.	ID #:	0001938	STOCK PART #:	CRS14
	MATERIAL:			
DESCRIPTION: CRS14 Concealed Stay Roller				
FINISH:			# PCS:	REV:



CROWN INDUSTRIAL
 So. San Francisco, Ca
 (650) 952-5150
 www.crown-industrial.com