



## PE-i30 LASER CURTAIN PACKAGE

Emitting from a single small compact unit, are four curtains of detection 30 feet x 30 feet x 3 feet. Can detect objects as small as 2 inches at 30 feet away dependant upon application.



### Package Includes:

- Laser Emitter/Sensor.
- Cable 30 ft.
- Laser Mounting Bracket



# CROWN INDUSTRIAL OPERATORS-CONTROLS

Door Hardware, Doors, Operators and Complete Systems

Manufacturer of Aut-o-doR® products

## SAFETY



The device contains IR and visible laser diodes.  
IR laser: wavelength 905nm; max. output pulse power 75W (Class 1 according to IEC 60825-1)  
Visible laser: wavelength 650nm; max. output CW power 3mW (Class 3R according to IEC 60825-1)

The visible laser beams are inactive during normal operation. The installer can activate the visible lasers if needed.



### CAUTION!

Use of controls, adjustments or performance of procedures other than those specified herein may result in hazardous laser radiation exposure.

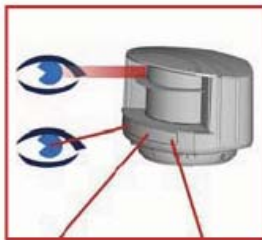

Do not look into the laser emitter or the visible red laser beams.



The warranty is void if unauthorized repairs are made or attempted by unauthorized personnel.



Only trained and qualified personnel may install and adjust the sensor.



Test for proper operation of the installation before leaving the premises.

The manufacturer of the door system is responsible for carrying out a risk assessment and installing the sensor and the door system in compliance with applicable national and international regulations and standards on door safety and if applicable, the machinery directive 2006/42/EC. Other use of the device is outside the permitted purpose and can not be guaranteed by the sensor manufacturer. The sensor manufacturer cannot be held responsible for incorrect installations or inappropriate adjustments of the sensor.

## INSTALLATION AND MAINTENANCE



Avoid extreme vibrations.

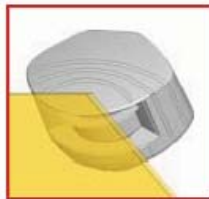

Do not cover the front screens.

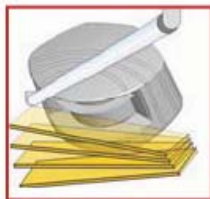

Avoid moving objects and light sources in the detection field.



Avoid the presence of smoke and fog in the detection field.

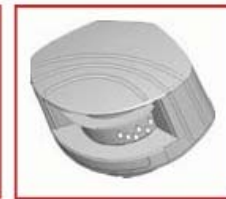

Avoid condensation.

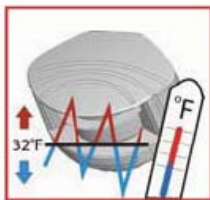

Avoid exposure to sudden and extreme temperature changes.



Avoid direct exposure to high pressure cleaning.



Do not use aggressive products to clean the front screens.



Wipe the front screens regularly with a clean and damp cloth.



Keep the sensor permanently powered in environments where the temperature can descend below 32°F.

Crown Industrial • 213 Michelle Ct. • So. San Francisco, Ca 94080-6202

Phone: (650) 952-5150 • Fax: (650) 873-1495

www.crown-industrial.com Email: autodor@crown-industrial.com



# CROWN INDUSTRIAL OPERATORS-CONTROLS

Door Hardware, Doors, Operators and Complete Systems

Manufacturer of Aut-o-doR® products

## TECHNICAL SPECIFICATIONS

Technology:	laser scanner, time-of-flight measurement
Detection mode:	motion and presence (EN 12453 Typ. E)
Max. detection range:	30 ft x 30 ft
Remission factor:	> 2 %
Angular resolution:	0,3516 °
Min. detected object size (typ.): (in proportion to object distance)	1 in @ 10 ft ; 1.5 in @ 15 ft ; 3 in @ 30 ft
Testbody:	27.6 in x 11.8 in x 7.9 in (testbody A according to EN 12445)
Emission characteristics:	
IR laser:	wavelength 905 nm; max. output pulse power 75 W (CLASS 1)
Red visible laser:	wavelength 650 nm; max. output CW power 3 mW (CLASS 3R)
Supply voltage:	12-35 V DC @ sensor side
Power consumption:	< 5 W
Peak current at power-on:	1.8 A @ 35V, 2.625 A @ 24V, 5.25 A @ 12V; max. 80 ms
Cable length:	30 ft
Response time:	typ. 20 ms; max. 80 ms
Output:	2 electronic relays (galvanic isolated - polarity free)
Max. switching voltage:	35 V DC / 24 V AC
Max. switching current:	80 mA (resistive)
Switching time:	t <sub>ON</sub> =5 ms; t <sub>OFF</sub> =5 ms
Output resistance:	typ 30 Ω
Voltage drop on output:	< 0.7 V @ 20 mA
Leakage current:	< 10 μA
Input:	2 optocouplers (galvanic isolated - polarity free)
Max. contact voltage:	35 V DC (over-voltage protected)
Voltage threshold:	Log. H: >8 V DC; Log. L: <3 V DC
Response time monitoring input:	< 5 ms
LED-signal:	1 blue LED: power-on status 1 orange LED: error status 2 bi-colored LEDs: detection/output status (green: no detection; red: detection)
Dimensions:	5.00 in (D) x 3.66 in (W) x 2.75 in (H) (mounting bracket + 0.55 in)
Material:	PC/ASA
Color:	black or white
Mounting angles on bracket:	-45 °, 0 °, 45 °
Rotation angles on bracket:	-5 ° to +5 ° (lockable)
Tilt angles on bracket:	-3 ° to +3 °
Protection degree:	IP65
Temperature range:	-22 °F to +140 °F if powered; 14 °F to +140 °F unpowered
Humidity:	0-95 % non-condensing
Vibrations:	< 2 G
Pollution on front screens:	max. 30 %; homogenous
Expected lifetime:	8 years
Norm conformity:	2006/95/EC: LVD; 2002/95/EC: RoHS; 2004/108/EC: EMC; 2006/42/EC: MD; EN 12453:2000 chapter 5.1.1.6, chapter 5.5.1 Safety device E; EN 12978:2009; EN ISO 13849-1:2008 Pl "d"/ CAT2; EN 60529:2001; IEC 60825-1:2007; EN 60950-1:2005; EN 61000-6-2:2005; EN 61000-6-3:2006; IEC 61496-1:2009; EN 61496-3:2008 ESPE Type 2; EN 62061:2005 SIL 2; DIN 18650-1:2010 Chapter 5.7.4

Specifications are subject to changes without prior notice.  
All values measured in specific conditions.



# CROWN INDUSTRIAL OPERATORS-CONTROLS

Door Hardware, Doors, Operators and Complete Systems

Manufacturer of Aut-o-doR® products

## TROUBLESHOOTING

	No blue LED	There is no power.	<b>1</b> Check cable and connection.
		The polarity of the power supply is inverted.	<b>1</b> Check the polarity of the power supply.
	Only the blue LED is on.	The test input is not connected.	<b>1</b> Check wiring. The BLUE and BLUE/WHITE wires have to be connected to the test input or the power supply.
	The detection LED remains green.	The detection field is too small or deactivated.	<b>1</b> Check the size of the fields. <b>2</b> Launch a teach-in.
		The object size is too small.	<b>1</b> Decrease the min. object size.
	The detection LED remains red.	Someone or something is in the detection field.	<b>1</b> Step out of the field and/or remove the any object(s) from the field.
		The field is touching the floor, the wall or the door, which leads to detection.	<b>1</b> Activate the 3 red beams and check if the position of the sensor is correct. If not, adjust the hex screws. <b>2</b> Verify the field size. <b>3</b> Launch a teach-in.
	The orange LED is flashing and the detection LEDs are red.	No background (reference point) is found.	<b>1</b> Check the position of the sensor. <b>2</b> Check the mounting side setting. If there is no background, set the mounting side to value 3 to 5. <b>3</b> Launch a new teach-in.
		The sensor is masked.	<b>1</b> Verify and clean the front screens with a clean, damp cloth.
	The orange LED is on. Both detection LEDs go orange.	The power supply voltage is exceeding the acceptable limits or is unstable.	<b>1</b> Check the power supply voltage. <b>2</b> Cycle the power.
		The sensor exceeds its temperature limits.	<b>1</b> Verify the outside temperature where the sensor is installed. If needed, protect the sensor from sunlight using a cover.
		Internal error	<b>1</b> Wait a few seconds. If the LED remains ON, cycle the power supply. If the LED turns on again, replace the sensor.
	The sensor does not respond to the remote control.	30 minutes after last use of the remote control, the sensor locks the access to the remote control session.	<b>1</b> Cycle the power. The remote control session will then be accessible for another 30 minutes.
		The batteries in the remote control are not installed properly or dead.	<b>1</b> Verify or replace the batteries.
		Improper remote control orientation.	<b>1</b> Point the remote control towards the sensor, but with a slight angle. The RC should not be pointed in a right angle in front of the sensor.
		A reflective object is in close proximity to the sensor.	<b>1</b> Avoid highly reflective material in proximity to the sensor.
		Monitoring wires not connect	<b>1</b> Connect the BLUE and BLUE/WHITE wires to the power supply.
	The sensor does not unlock.	Monitoring wires not connect	<b>1</b> Connect the BLUE and BLUE/WHITE wires to the power supply.
		You have to enter an access code or the wrong code was entered.	Cycle the power. <b>1</b> No code is required to unlock during the first minute after powering.

Crown Industrial • 213 Michelle Ct. • So. San Francisco, Ca 94080-6202

Phone: (650) 952-5150 • Fax: (650) 873-1495

www.crown-industrial.com Email: autodor@crown-industrial.com



# CROWN INDUSTRIAL OPERATORS-CONTROLS

Door Hardware, Doors, Operators and Complete Systems

Manufacturer of Aut-o-doR® products

## DESCRIPTION

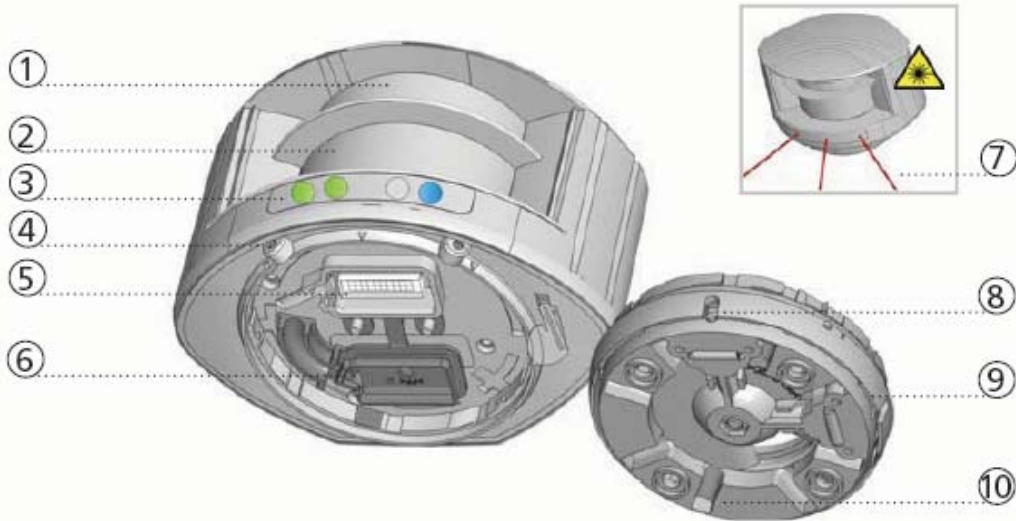

- |                                |  |
|--------------------------------|--|
| 1. laser sweep emission        | 6. protection cover                    |
| 2. laser sweep reception       | 7. visible laser beam (3)              |
| 3. LED-signal (4)              | 8. notch for tilt angle adjustment (2) |
| 4. screw for position lock (2) | 9. adjustable bracket                  |
| 5. connector                   | 10. cable conduit (4)                  |

## LED-SIGNAL

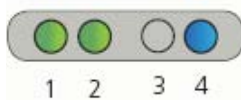

1. Detection LED: relay 1 - optional field
2. Detection LED: relay 2 - safety field
3. Error LED
4. Power LED

### DETECTION LEDs

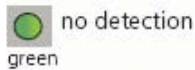
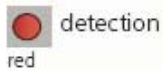

### ERROR LED



### POWER LED



LED flashes quickly



LED flashes



LED flashes slowly



LED is off

## SYMBOLS



Caution!  
Laser radiation

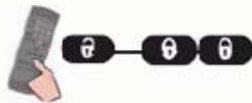

Remote control  
sequence



Possible  
remote control  
adjustments



Factory  
values



According  
to



Not  
according  
to



# CROWN INDUSTRIAL OPERATORS-CONTROLS

Door Hardware, Doors, Operators and Complete Systems

Manufacturer of Aut-o-doR® products

## 1 MOUNTING

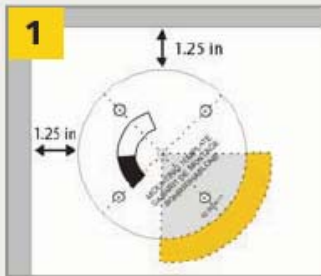
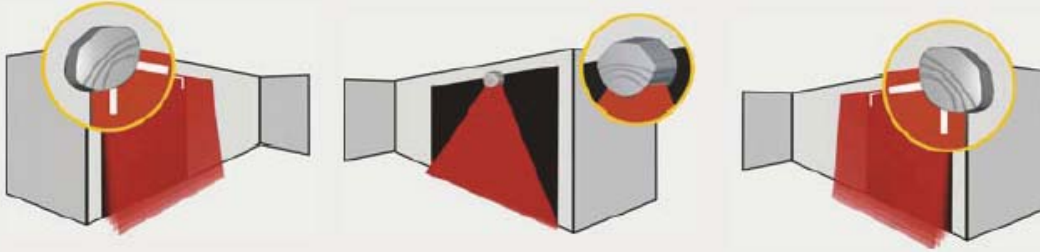

Use the adhesive mounting template to position the sensor correctly. The grey area indicates the detection range.



Drill 4 holes as indicated on the mounting template. Drill a hole (1/2 in minimum) for the cable if possible.



Pass the cable +/- 4 inches through the cable opening. If drilling an opening is not possible, use the cable conduits on the back side of the bracket.



Position the bracket and fasten the 4 screws firmly in order to avoid vibrations.



Open the protection cover, plug the connector and position the cable in the channel.



Close the protection cover and fasten it firmly. NOTE: Factory warranty voided if protection cover is not used!



Position the housing on the bracket.



Turn the sensor until the two triangles are face to face.

Crown Industrial • 213 Michelle Ct. • So. San Francisco, Ca 94080-6202

Phone: (650) 952-5150 • Fax: (650) 873-1495

www.crown-industrial.com Email: autodor@crown-industrial.com



# CROWN INDUSTRIAL OPERATORS-CONTROLS

Door Hardware, Doors, Operators and Complete Systems

Manufacturer of Aut-o-doR® products

## HOW TO USE THE REMOTE CONTROL



After unlocking, the red LED flashes and the sensor can be adjusted by remote control.



If the red LED flashes quickly after unlocking, you need to enter an access code from 1 to 4 digits.



To end an adjustment session, always lock the sensor.

## ADJUSTING ONE OR MORE PARAMETERS



## CHECKING A VALUE

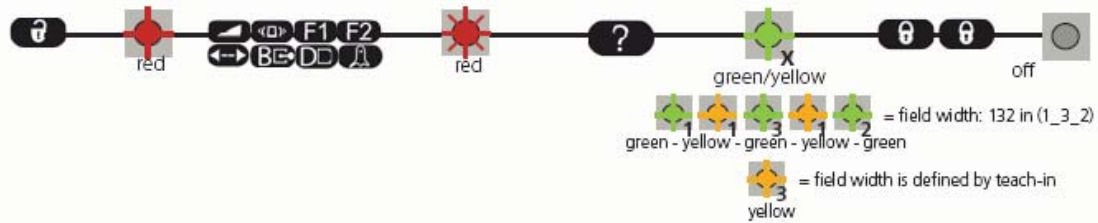

## RESTORING TO FACTORY VALUES



## SAVING AN ACCESS CODE

The access code is recommended for sensors installed close to each other.

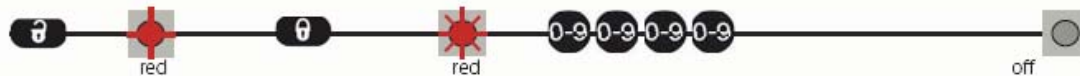

## DELETING AN ACCESS CODE



30 minutes after last use, the sensor locks the access to the remote control session. To regain access, cycle the power. The remote control session will then be accessible for another 30 minutes.





# CROWN INDUSTRIAL OPERATORS-CONTROLS

Door Hardware, Doors, Operators and Complete Systems

Manufacturer of Aut-o-doR® products

## OPTIONAL FIELD CONFIGURATIONS

Make sure the white and green wires are connected to the corresponding inputs before you choose one of the following two configurations.

### OPTIONAL FIELD DETECTION

(optional field only, Curtains A-D, Relay 1)

Configure an optional detection field if desired.



**1** After setting the mounting side, the safety and the optional field will have the same dimensions.

**2** Adjust the size of the optional field by remote control.



**3** Change the output redirection if needed.

	WIDTH	MIN	MAX
<b>A</b>	000 same as safety	002 2 in	360 360 in
<b>B</b>	000 no field	002 2 in	360 360 in

### VIRTUAL PUSH BUTTON

Install 1 or 2 virtual push buttons as activation zone(s) to open the door manually.

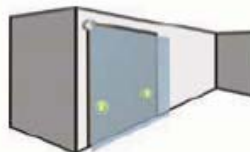

**1** Apply the virtual push button sticker(s) **within the opening field**. Adjust the field size large enough to accommodate the virtual push button.

**2** Launch a teach-in to configure the detection zone(s). Launch a new teach-in each time the sensor position is changed or new objects are added to or changed in the detection zone. **ATTENTION!** This teach-in is different from the safety field teach-in.

When the red LED flashes very slowly after 3 seconds, hold your hand in front of the sticker to learn the detection zone. The green LED flashes 3x to confirm the selection.

When the red LED flashes again, learn a second (max. 2) detection zone or wait until the LED switches to green.

NOTE: Always be sure the Opening Field (Curtain D, Relay 1) is defined slightly wider and/or higher than the position of the Virtual Push Button.

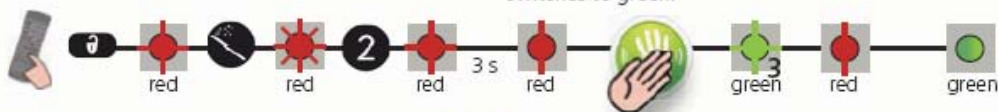

**3** Change the output redirection if needed.

Crown Industrial • 213 Michelle Ct. • So. San Francisco, Ca 94080-6202

Phone: (650) 952-5150 • Fax: (650) 873-1495

www.crown-industrial.com Email: autodor@crown-industrial.com





# CROWN INDUSTRIAL OPERATORS-CONTROLS

Door Hardware, Doors, Operators and Complete Systems

Manufacturer of Aut-o-doR® products

## 2 WIRING

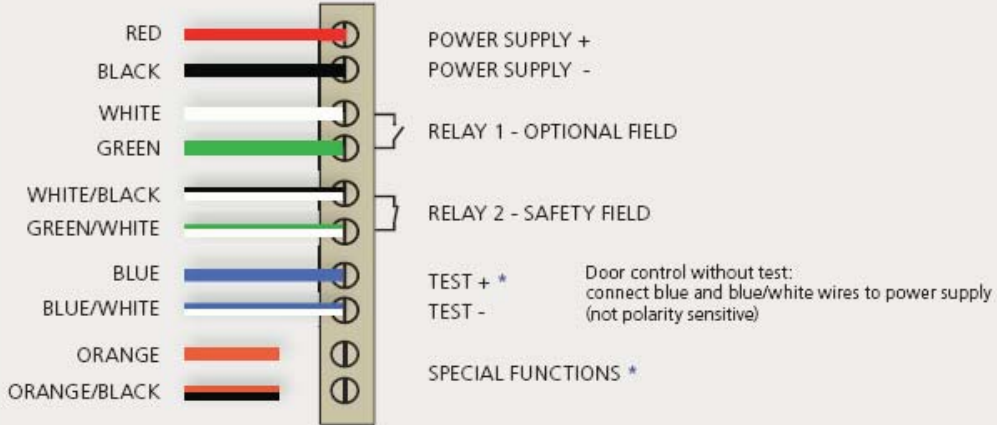

\* SEE APPLICATION NOTES OR CONTACT BEA FOR TECHNICAL SUPPORT

## 3 POSITIONING



Unlock the sensor and activate the visible laser beams.

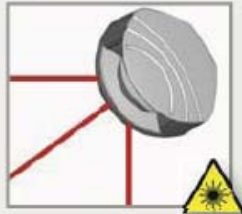

The visible laser beams indicate the approximate position of the inner most curtain (A) and the angle of the detection field.

The visible laser beams will remain active for 15 minutes or can be turned off the same way they were activated.



Adjust the **lateral position** of the detection field.



Adjust the **tilt angle** of the detection field with the 3mm hex key.



**Lock the position** of the mounting bracket to avoid malfunctioning in case of extreme vibrations.



### CAUTION!

The distance between the inner curtains of the 2 sensors must not exceed 7 7/8 in.

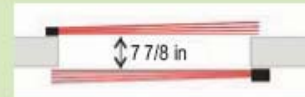



# CROWN INDUSTRIAL OPERATORS-CONTROLS

Door Hardware, Doors, Operators and Complete Systems

Manufacturer of Aut-o-doR® products

## 4 MOUNTING SIDE

Select the corresponding mounting side.

Stay outside of the detection field to avoid disturbances.

The sensor learns its environment and automatically determines the detection field(s). Both RED LEDs flash slowly and the 3 visible laser beams automatically light up for 30 seconds.

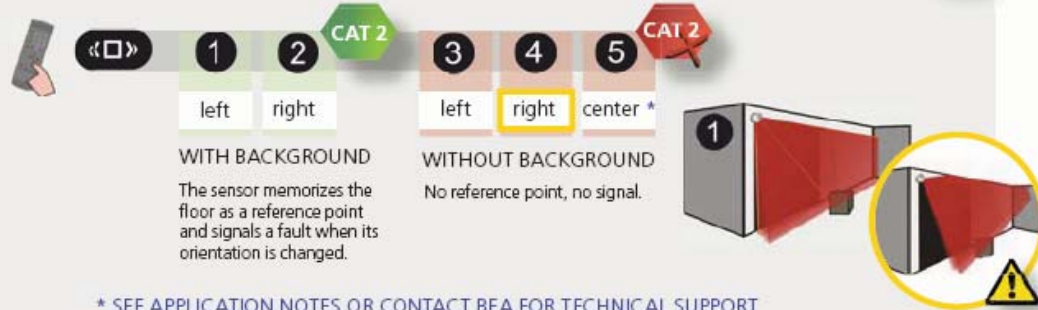

\* SEE APPLICATION NOTES OR CONTACT BEA FOR TECHNICAL SUPPORT

## 5 SAFETY FIELD DIMENSIONS

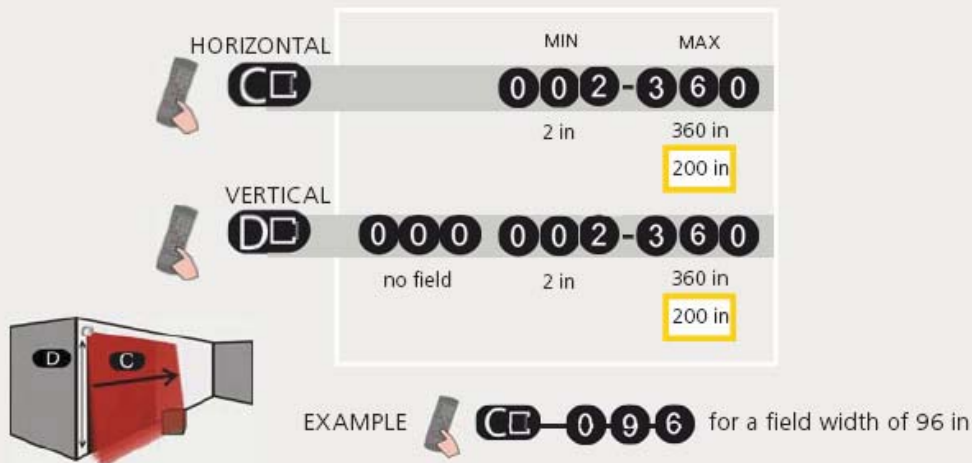

**IMPORTANT:** Test the proper operation of the installation before leaving the premises.

### TEACH-IN

Launch a teach-in after changing the sensor position or when new objects are added to or changed in the detection zone.

The detection field should be free of heavy rain, snowfall, fog or other moving objects.

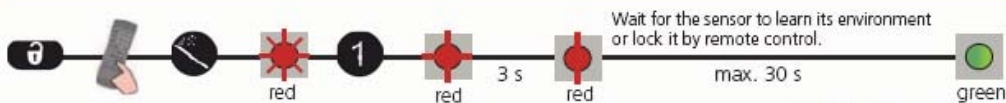

During teach-in, the sensor learns its surroundings and adapts the detection field shape. Objects in the detection field will be cut out.





# CROWN INDUSTRIAL OPERATORS-CONTROLS

Door Hardware, Doors, Operators and Complete Systems

Manufacturer of Aut-o-doR® products

## REMOTE CONTROL ADJUSTMENTS (OPTIONAL)

### NUMBER OF ACTIVE SAFETY CURTAINS (safety field only, Relay 2)

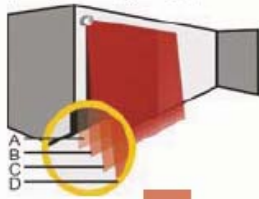

ACTIVE CURTAIN

	←→	1	2	3	4	5	6	7	8	9
A		■	■	■	■					
B			■	■	■	■			■	
C				■	■	■	■			■
D					■	■	■	■		

The distances between the curtains depend on the mounting height and side. When mounted on the left, the distance between the first (A) and the last (D) curtain is approximately 4 in for every 3 ft (mounting height).  
**Example:** at 15 ft the distance is 20 in.

### UNCOVERED ZONE

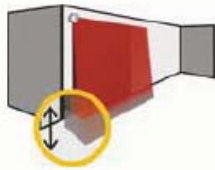

F2	0	1	2	3	4
	2	4	6	8	10 in
	CAT 2			CAT 2	

Increase in case of snow, debris, etc.

### IMMUNITY FILTER

	1	2	3	4
	indoor	outdoor low	outdoor med	outdoor high
	CAT 2		CAT 2	

Increased immunity relative to field size

### MIN. OBJECT SIZE (approximate values)

	0	1	2	3	4
	off	3	4	6	8 in
	CAT 2				CAT 2

### OUTPUT CONFIGURATION \*

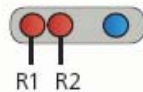

	1	2	3	4
R1 (optional)	A - NO	P - NC	P - NC	A - NO
R2 (safety)	P - NC	A - NO	P - NC	A - NO

A = active  
P = passive

### OUTPUT REDIRECTION

F1	0	1
R1	opening	opening or safety
R2	safety	safety

\* SEE APPLICATION NOTES OR CONTACT BEA FOR TECHNICAL SUPPORT