

4

3

2

1

D

D

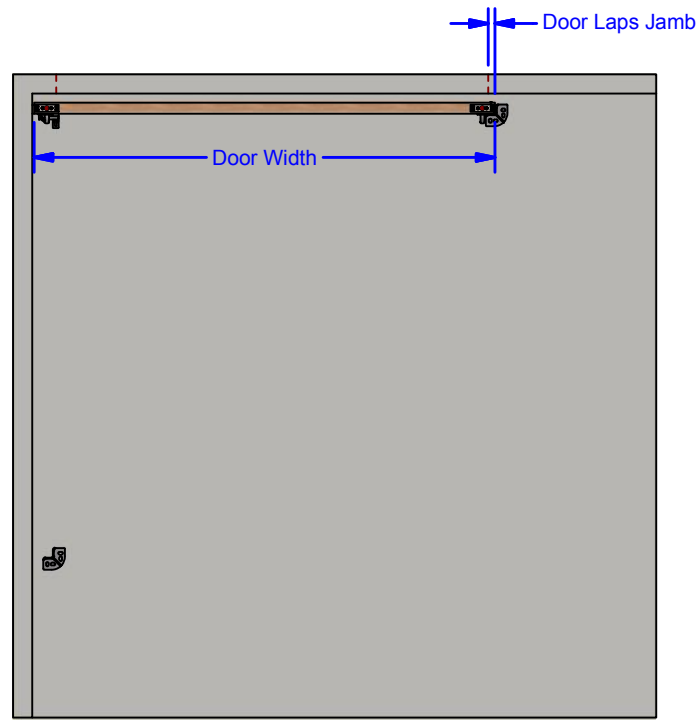
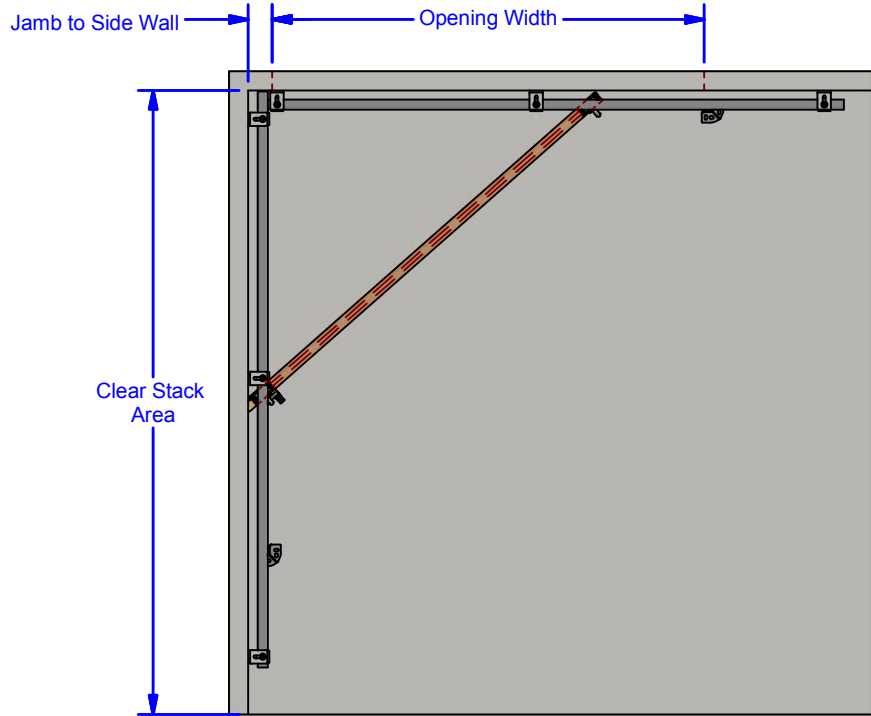

C

C

B

B

A

A

Indicate the Following:

1. Width of Opening:
2. Door Width:
3. Thickness of Door:
4. Distance door laps on jamb:
5. Distance from jamb to side wall.
6. Clear Stack Area.

DWG #: 0002553
 DRAWN:BCM 10/9/2017
 SHEET #1
 File: 0002553.idw

ALL DIMENSIONS IN INCHES

THE INFORMATION CONTAINED IN THIS DRAWING IS THE SOLE PROPERTY OF CROWN INDUSTRIAL. ANY REPRODUCTION IN PART OR AS A WHOLE WITHOUT THE WRITTEN PERMISSION OF CROWN INDUSTRIAL IS PROHIBITED.	ID #:	STOCK PART #:
	0002551	
MATERIAL:		
DESCRIPTION:		
Right Angle Door w. Perpendicular Hardware		
FINISH:	# PCS:	REV:
	1	



CROWN INDUSTRIAL
 So. San Francisco, Ca
 (650) 952-5150
 www.crown-industrial.com

4

3

2

1



4

3

2

1

D

D

C

C

B

B

A

A

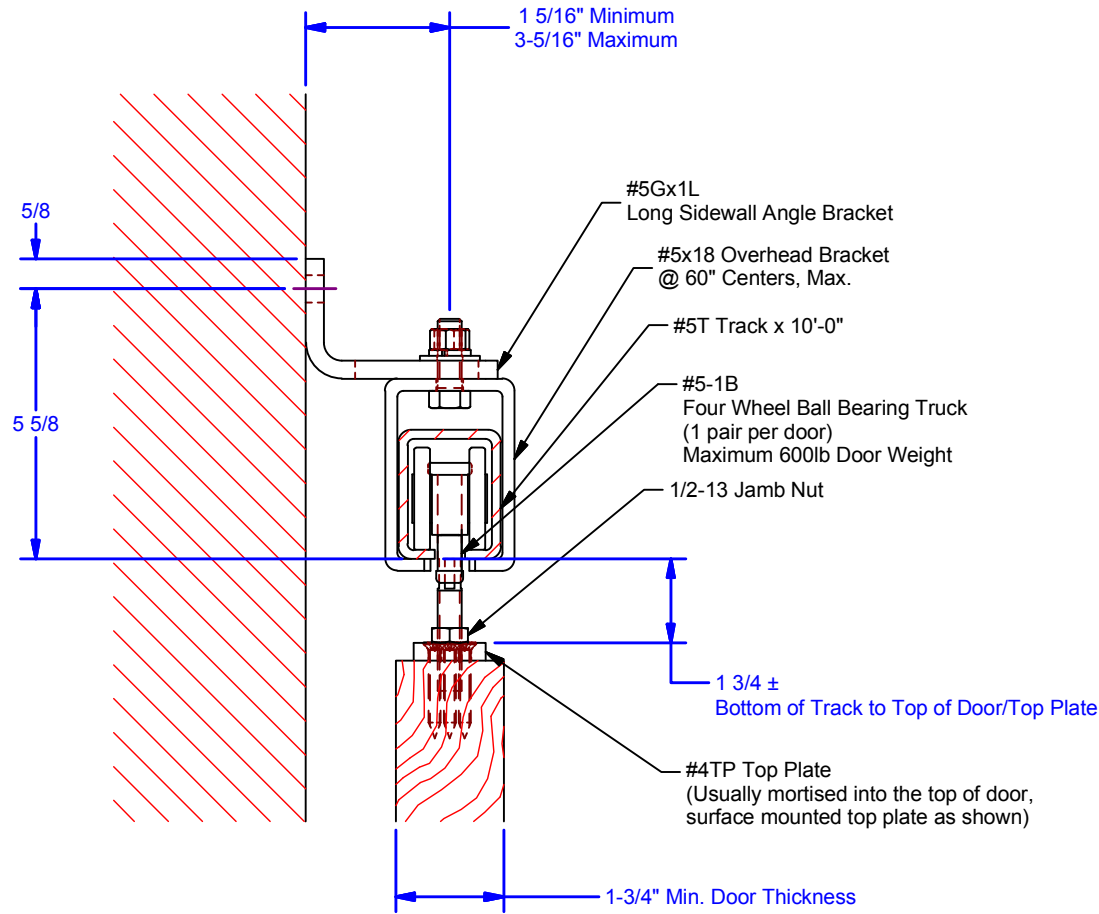

SECTION A-A
Head Sectional Detail
SCALE 1/4

ALL DIMENSIONS IN INCHES

THE INFORMATION CONTAINED IN THIS DRAWING IS THE SOLE PROPERTY OF CROWN INDUSTRIAL. ANY REPRODUCTION IN PART OR AS A WHOLE WITHOUT THE WRITTEN PERMISSION OF CROWN INDUSTRIAL IS PROHIBITED.	ID #:	0002551	STOCK PART #:
	MATERIAL:		
DESCRIPTION: Right Angle Door w. Perpendicular Hardware			
FINISH:	# PCS:	1	REV:



CROWN INDUSTRIAL
So. San Francisco, Ca
(650) 952-5150
www.crown-industrial.com

DWG #: 0002553
DRAWN: BCM 10/9/2017
SHEET #2
File: 0002553.idw

4

3

2

1