

**INDICATE:**

1. OPENING WIDTH:
2. DOOR WIDTH:
3. DOOR THICKNESS:
4. EDGE OF DOOR TO CENTER OF HANGER:
5. PROJECTION OF MATERIALS BEYOND WALL BLOCKING:  
(FOR WALL SPACER LENGTH-SEE SHEET 2)
6. FIELD OR FACTORY DRILLED TRACK MOUNTING HOLES

44 FLAT TRACK  
 DWG #44H  
 DESCRIP: 44H ELEVATION- BIPARTING  
 DRAWN:BCM 8-14-08  
 SCALE: NONE  
 SHEET # 1

FILE:\crown-fs\main\engineering\hardware\44\44 customer template

THE INFORMATION CONTAINED IN THIS DRAWING IS THE SOLE PROPERTY OF CROWN INDUSTRIAL. ANY REPRODUCTION IN PART OR AS A WHOLE WITHOUT WRITTEN PERMISSION OF CROWN INDUSTRIAL IS PROHIBITED.



**CROWN INDUSTRIAL**

So. San Francisco, Ca  
 (650) 952-5150  
 www.crown-industrial.com

Projection of Materials  
Beyond Wall Blocking  
(i.e. Sheetrock, Trim, Baseboard)  
**(INDICATE)**

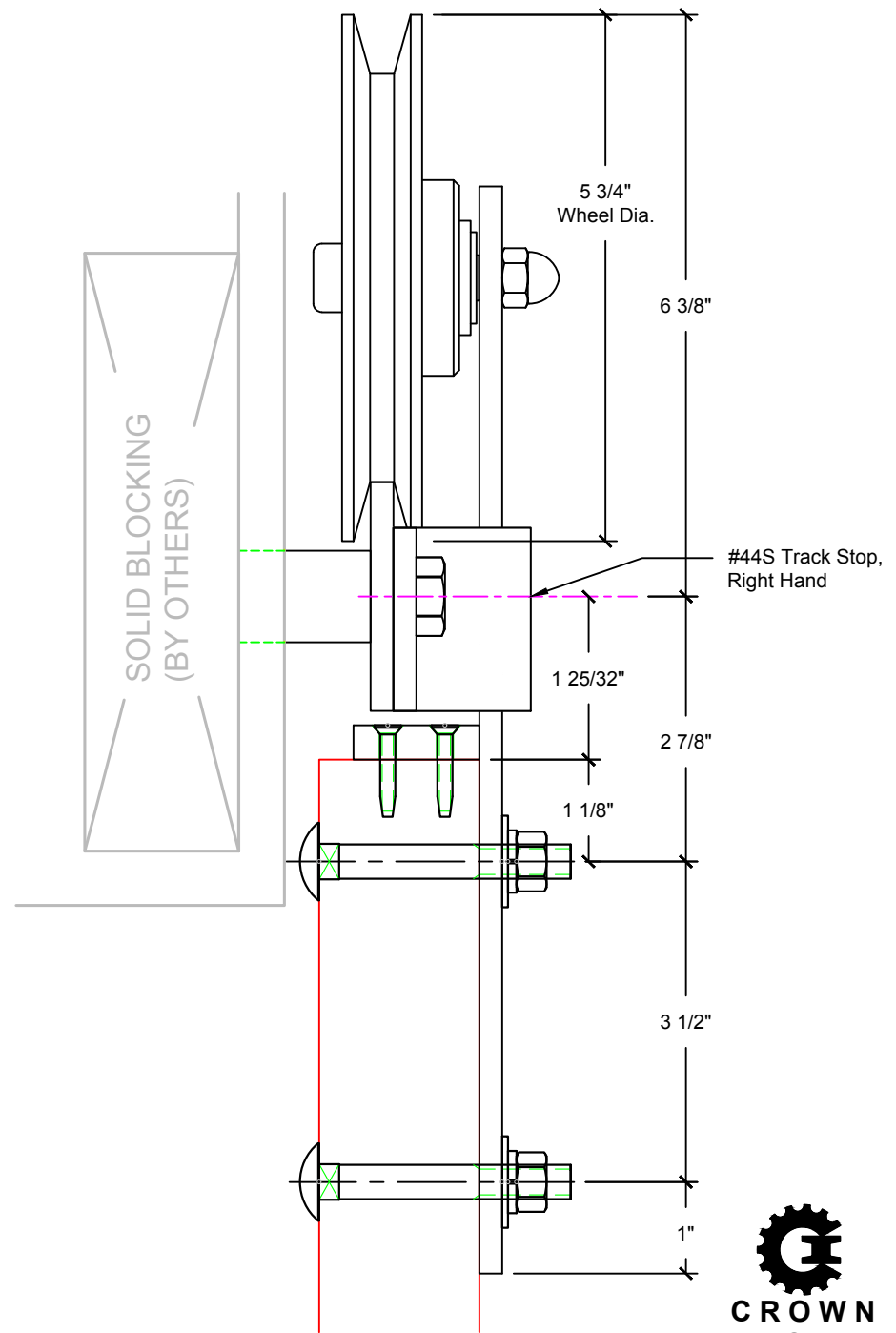
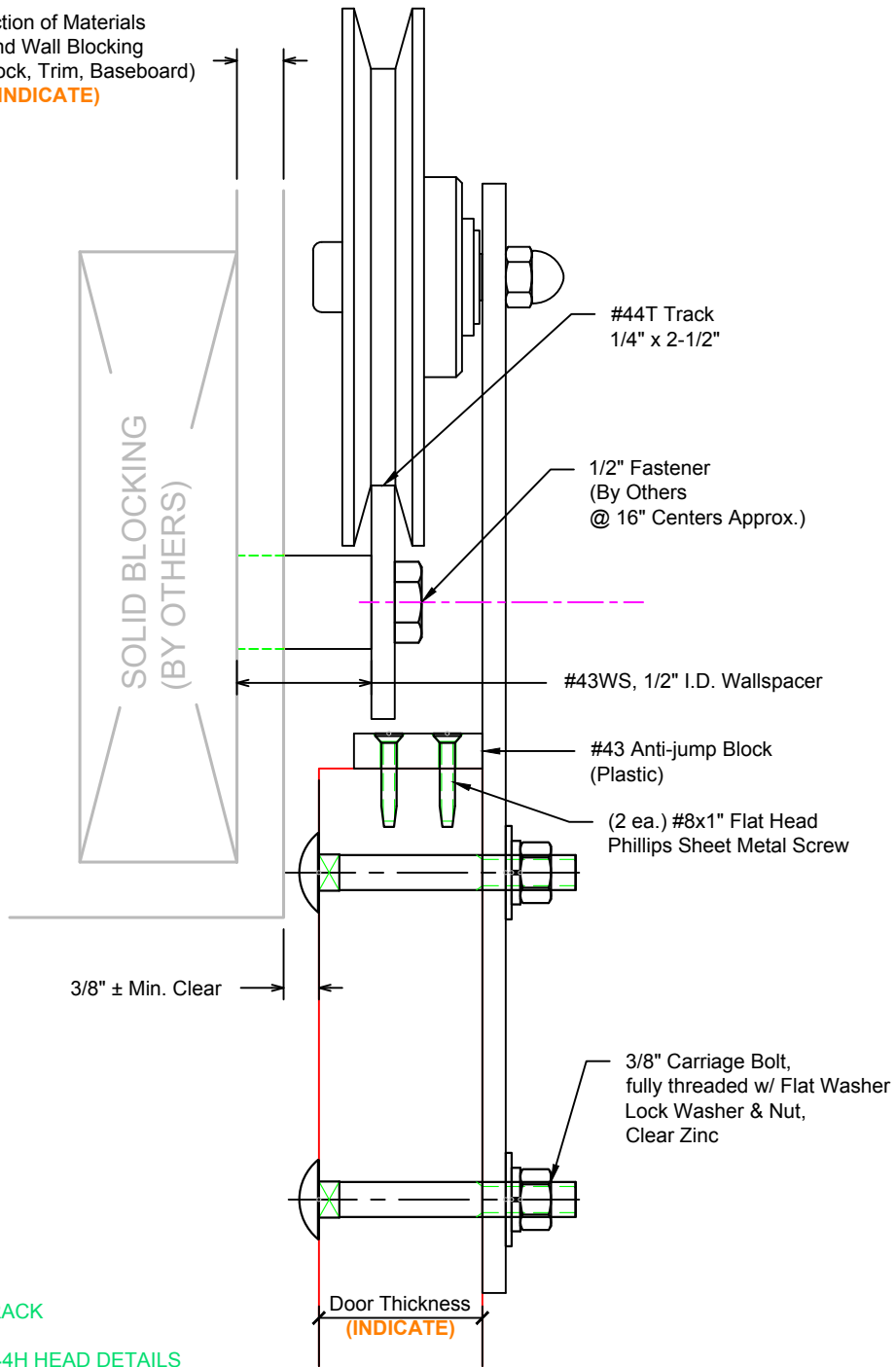

44 FLAT TRACK  
DWG #44H  
DESCRIP: 44H HEAD DETAILS  
DRAWN:BCM 8-14-08  
SCALE: NONE  
SHEET # 2

FILE: \\crown-fs\main\engineering\hardware\44\44 customer template

THE INFORMATION CONTAINED IN THIS DRAWING IS THE SOLE PROPERTY  
OF CROWN INDUSTRIAL. ANY REPRODUCTION IN PART OR AS A WHOLE  
WITHOUT WRITTEN PERMISSION OF CROWN INDUSTRIAL IS PROHIBITED.



**CROWN  
INDUSTRIAL**

So. San Francisco, Ca  
(650) 952-5150  
www.crown-industrial.com