

4X \varnothing Countersunk Holes
For 1/4 Flat Head Fasteners,
(Fasteners By Others)

Bottom View Of Roller

1 5/16
For 1-3/4"
Thick
Door
Minimum

#916 Bottom Roller, Brass Wheel
(600 lb Capacity per Pair)

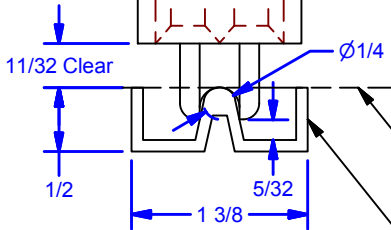
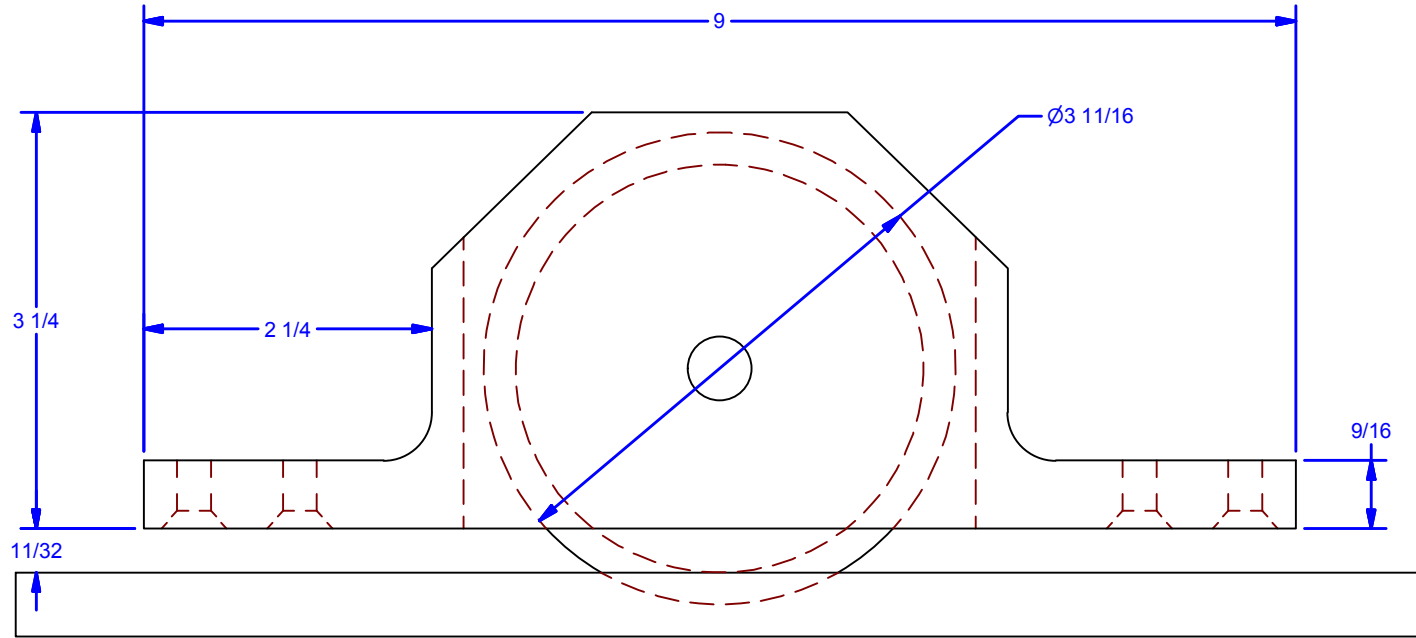
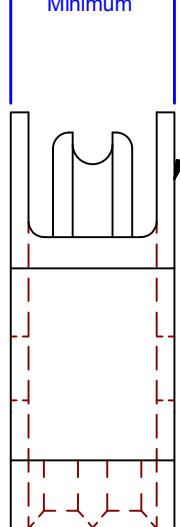

Finished Floor

#917 Floor Track, Brass
Available Lengths:
#917T1500: 4'-11" Long
#917T3000: 9'-10" Long

ALL DIMENSION $\pm 1/32"$
***DO NOT USE AS TEMPLATE, REFERENCE ONLY DRAWING**

ALL DIMENSIONS IN INCHES

THE INFORMATION CONTAINED IN THIS DRAWING IS THE SOLE PROPERTY OF CROWN INDUSTRIAL. ANY REPRODUCTION IN PART OR AS A WHOLE WITHOUT THE WRITTEN PERMISSION OF CROWN INDUSTRIAL IS PROHIBITED.	PART #:	STOCK #:
	0001685	
DESCRIPTION:		
916 Bottom Roller / 917 Track		
FINISH:	# PCS:	REV:
	1	



CROWN INDUSTRIAL
So. San Francisco, Ca
(650) 952-5150
www.crown-industrial.com

DWG #: 916BR
DRAWN:BCM 6/26/2014
SHEET #2
File: 0000655.idw