

4

3

2

1

D

D

C

C

B

B

A

A

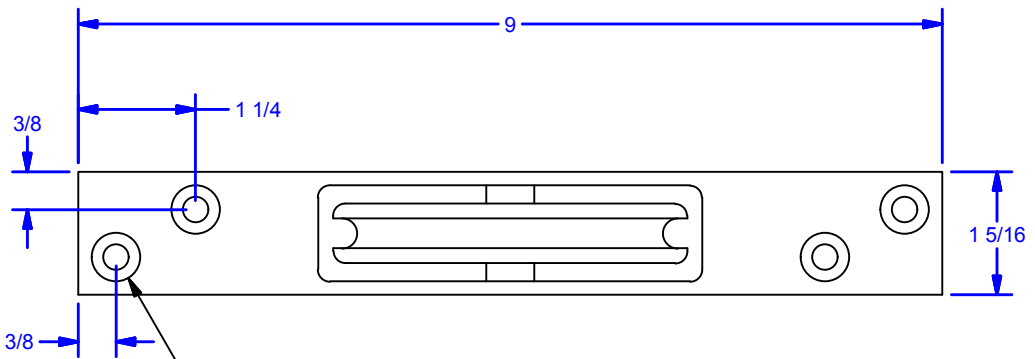
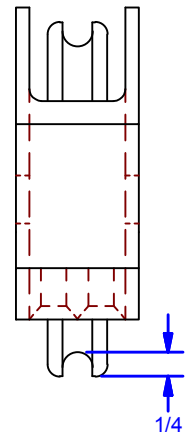
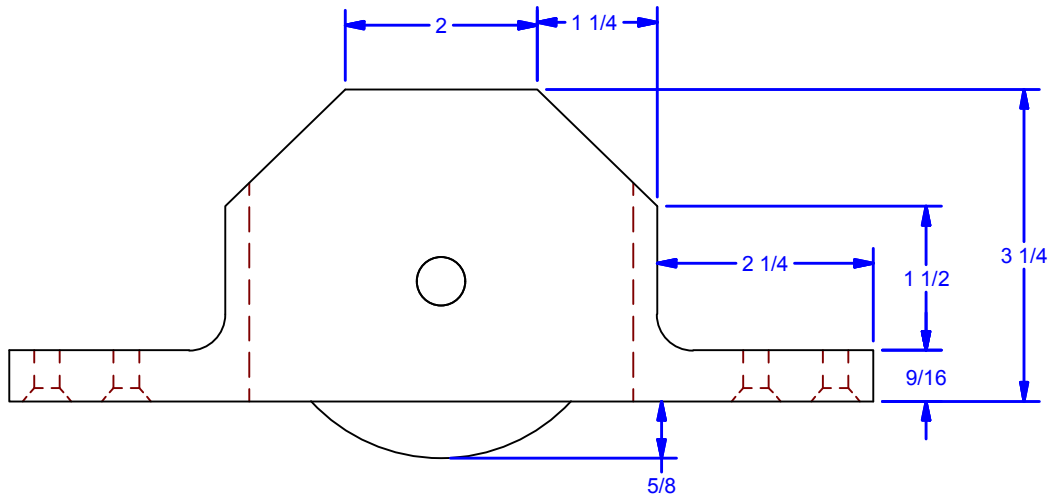

4X Ø COUNTERSUNK
For 1/4 Flat Head Machine Screw (82)
(REFERENCE ONLY)

ALL DIMENSION ± 1/32"
***DO NOT USE AS TEMPLATE, REFERENCE ONLY DRAWING**

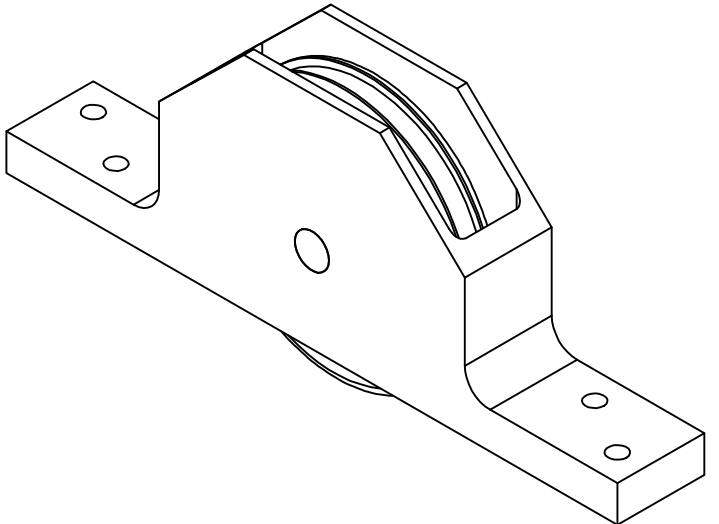

ALL DIMENSIONS IN INCHES

THE INFORMATION CONTAINED IN THIS DRAWING IS THE SOLE PROPERTY OF CROWN INDUSTRIAL. ANY REPRODUCTION IN PART OR AS A WHOLE WITHOUT THE WRITTEN PERMISSION OF CROWN INDUSTRIAL IS PROHIBITED.

PART #: 0000655

STOCK #: 916

MATERIAL: Brass

DESCRIPTION:
Bottom Roller, Cap 600 lbs. (reference only)

FINISH:

| | |
|--------|---|
| # PCS: | 2 |
| REV: | |



CROWN INDUSTRIAL
So. San Francisco, Ca
(650) 952-5150
www.crown-industrial.com

DWG #: 916BR
DRAWN:BCM 8/20/2009
SHEET #1
File: 0000655.idw

4

3

2

1

