

4

3

2

1

D

D

C

C

B

B

A

A

Hood Mounting Holes @ 16" O.C.
for #10 Pan Head Screw (By Others)
(Field Located and Drill Mounting Holes)
[Holes Not Shown for Clarity]

Field Apply Caulking
b/t Hood & Wall (By Others)

1 1/2

1 ±

5/8 Max Shim

#0002535
Hood Stiffener, S.S.
@ 8'-0" Centers
(Attaches to #25x1
Center Bracket)

17 1/2 ±

4 3/4 I.D.

5 1/2

#296-25-10
Hood Length x 10'-0"

#296-25-10
Hood Length x 10'-0"

3

#296-25x2
End Cap, Left Hand

#296-25x2
End Cap, Right Hand

#296-25SP
Track Hood Splice
(Rivet/Drill to Hood, By Others)

ALL DIMENSIONS IN INCHES

THE INFORMATION CONTAINED IN THIS
DRAWING IS THE SOLE PROPERTY OF
CROWN INDUSTRIAL. ANY REPRODUCTION
IN PART OR AS A WHOLE WITHOUT THE
WRITTEN PERMISSION OF CROWN
INDUSTRIAL IS PROHIBITED.

ID #:
0002494

STOCK PART #:
296-25

MATERIAL:

DESCRIPTION:

Weather Hood Assembly for #25 Track

FINISH:

Galvanized

PCS:

1

REV:

DWG #: 0002492
DRAWN:BCM 9/29/2017
SHEET #2
File: 0002492.idw



**CROWN
INDUSTRIAL**

So. San Francisco, Ca
(650) 952-5150

www.crown-industrial.com

4

3

2

1

4

3

2

1

Parts List				
ITEM	QTY	ID #	DESCRIPTION	STOCK PART #
1	1	0000456	Center Bracket	25x1
2	1	0002535	Hood Stiffener	0002535
3	1	FW 3/4 - Regular - Type B zinc	Flat Washer-zinc	
4	1	HN 3/4 - 10 Zinc-5	Hex Nut - Grade 5, Zinc	
5	1	HHMB 3/4-10 UNC - 1.25 Zinc -5	Hex Head Machine Bolt -Grade 5, Zinc	

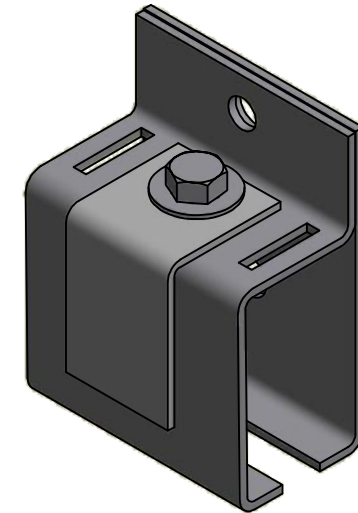
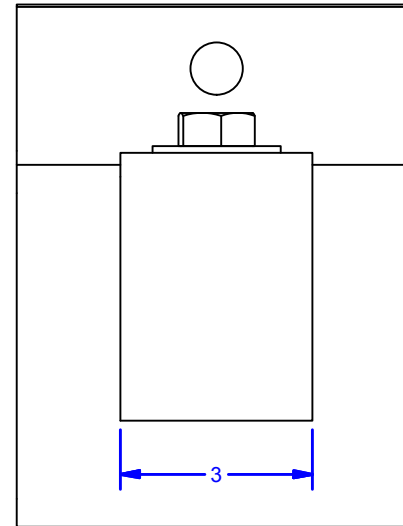
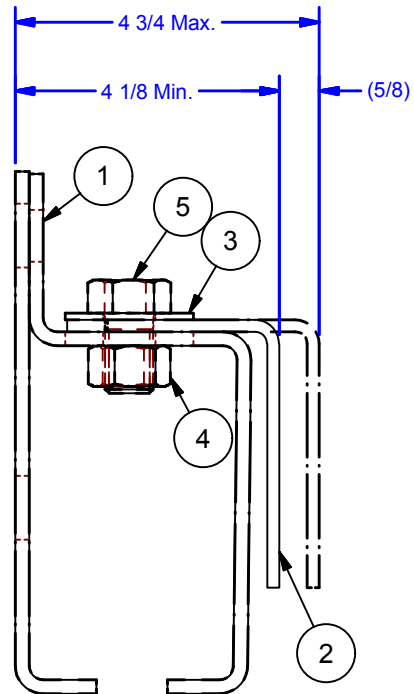

ALL DIMENSIONS IN INCHES

THE INFORMATION CONTAINED IN THIS DRAWING IS THE SOLE PROPERTY OF CROWN INDUSTRIAL. ANY REPRODUCTION IN PART OR AS A WHOLE WITHOUT THE WRITTEN PERMISSION OF CROWN INDUSTRIAL IS PROHIBITED.

DESCRIPTION:

Bracket w. Hood Stiffener

FINISH:

ID #:

0002536

STOCK PART #:

MATERIAL:

PCS:

1

REV:

DWG #: 0002492
DRAWN:BCM 9/29/2017
SHEET #3

File: 0002492.idw



CROWN INDUSTRIAL

So. San Francisco, Ca
(650) 952-5150

www.crown-industrial.com

4

3

2

1