

4

3

2

1

D

D

C

C

B

B

A

A

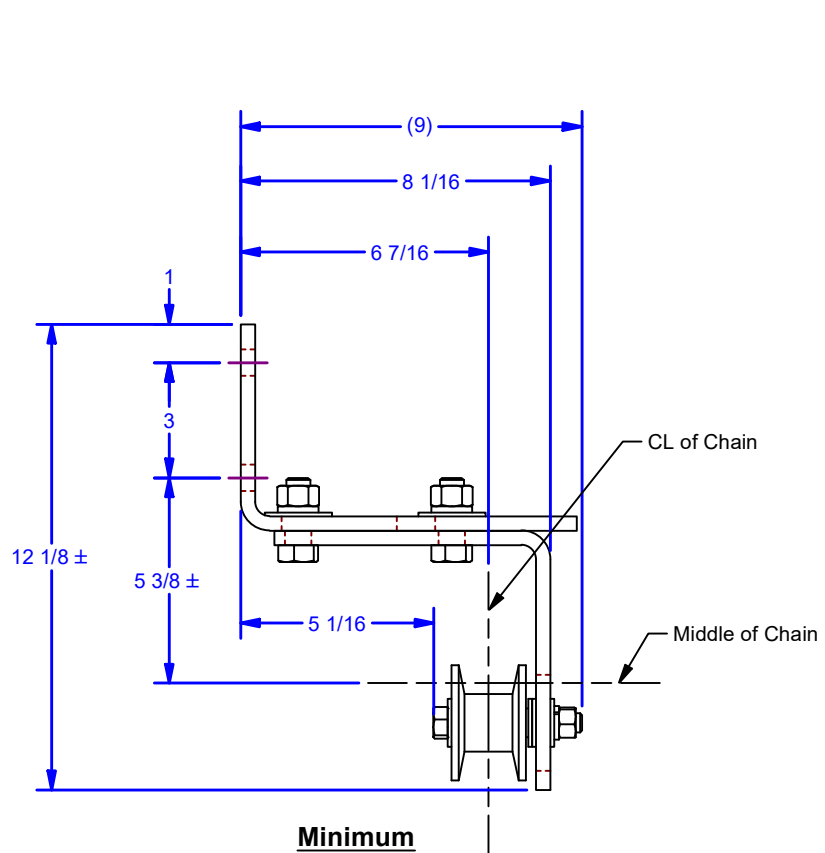

Minimum

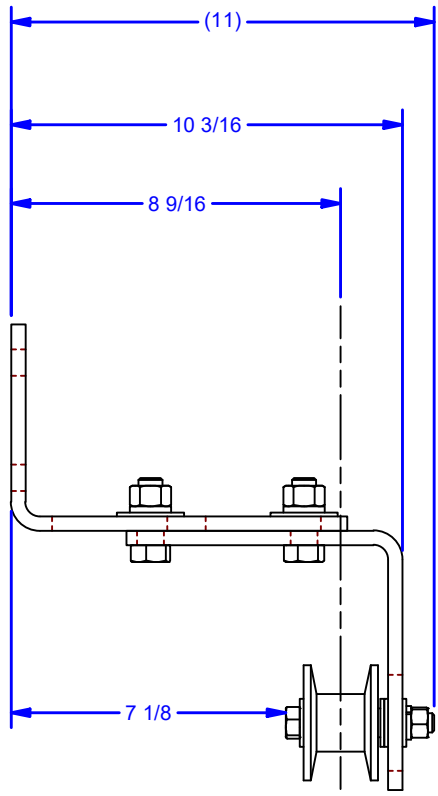

Maximum

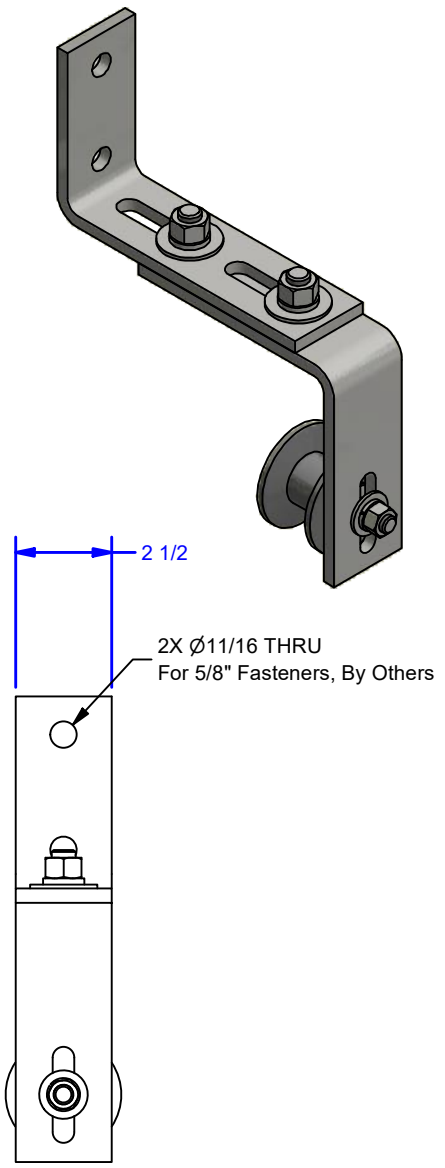

For openings equal or greater than 14'-0" wide

ALL DIMENSIONS IN INCHES

THE INFORMATION CONTAINED IN THIS DRAWING IS THE SOLE PROPERTY OF CROWN INDUSTRIAL. ANY REPRODUCTION IN PART OR AS A WHOLE WITHOUT THE WRITTEN PERMISSION OF CROWN INDUSTRIAL IS PROHIBITED.	ID #:	1265P179	STOCK PART #:	067611
	DESCRIPTION:		Single Chain Guide	
FINISH:	Painted	# PCS:	REV:	A

CROWN INDUSTRIAL
So. San Francisco, Ca
(650) 952-5150
www.crown-industrial.com

DWG #: 1265P179
DRAWN:BCM 5/23/2011
SHEET #1
File: 1265P179.idw

4

3

2

1

