

4

3

2

1

D

D

C

C

B

B

A

A

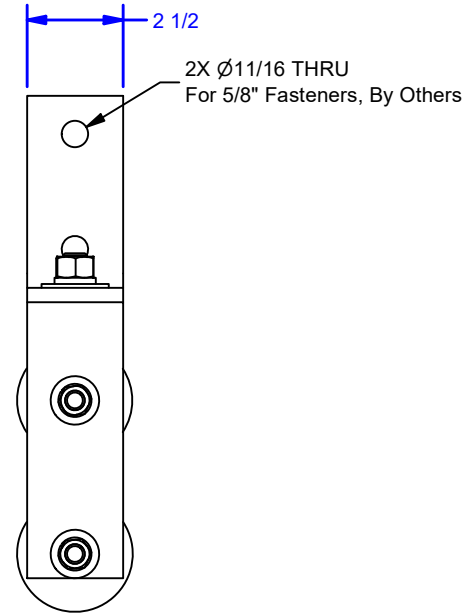
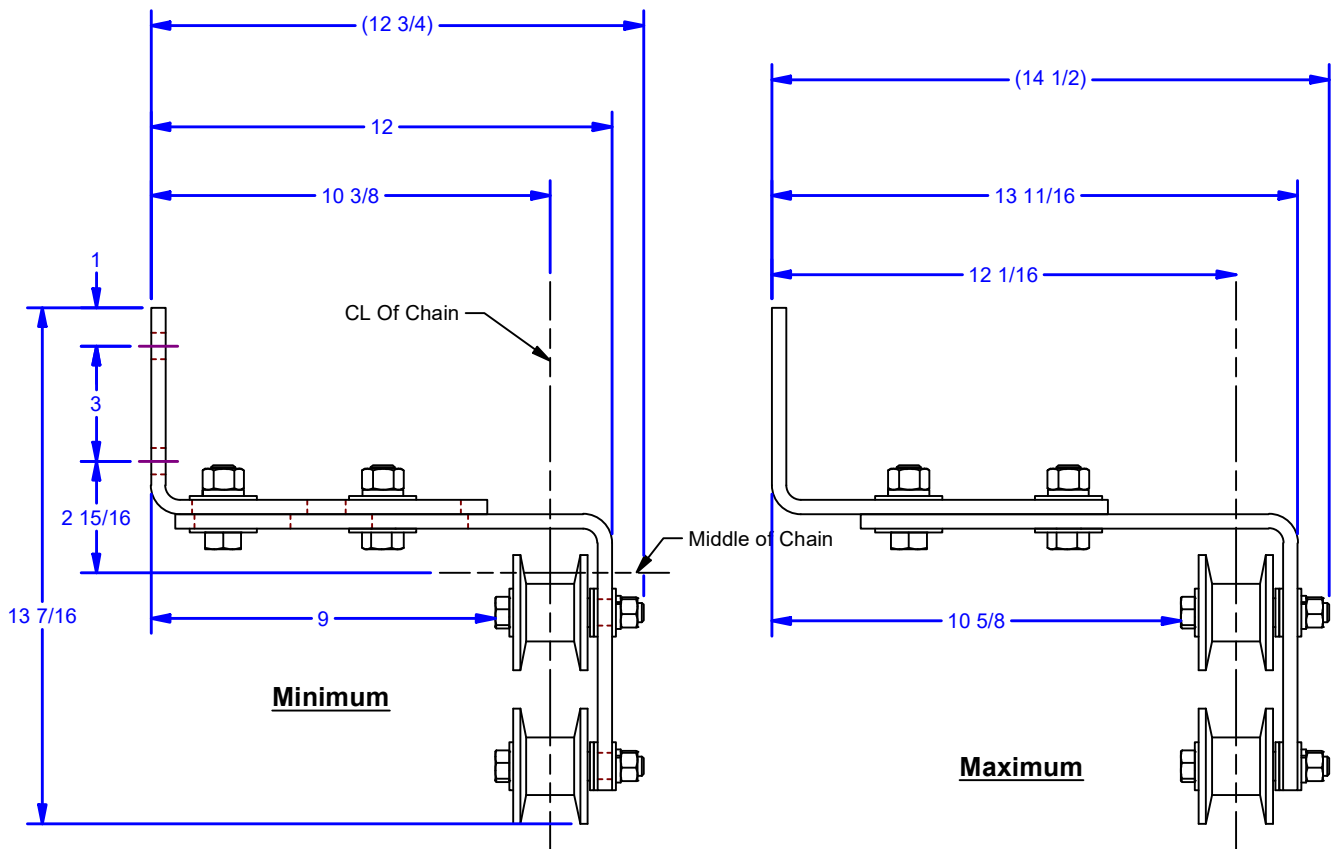
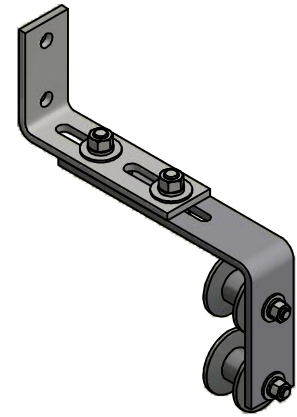

For openings equal or greater than 14'-0" wide

ALL DIMENSIONS IN INCHES

THE INFORMATION CONTAINED IN THIS DRAWING IS THE SOLE PROPERTY OF CROWN INDUSTRIAL. ANY REPRODUCTION IN PART OR AS A WHOLE WITHOUT THE WRITTEN PERMISSION OF CROWN INDUSTRIAL IS PROHIBITED.	ID #:	1265P180	STOCK PART #:	067612
	DESCRIPTION:		Double Chain Guide	
FINISH:	Painted	# PCS:	REV:	A



**CROWN INDUSTRIAL**  
 So. San Francisco, Ca  
 (650) 952-5150  
 www.crown-industrial.com

DWG #: 1265P179  
 DRAWN: BCM 5/23/2011  
 SHEET #2  
 File: 1265P179.idw

4

3

2

1

