

4

3

2

1

D

D

C

C

B

B

A

A

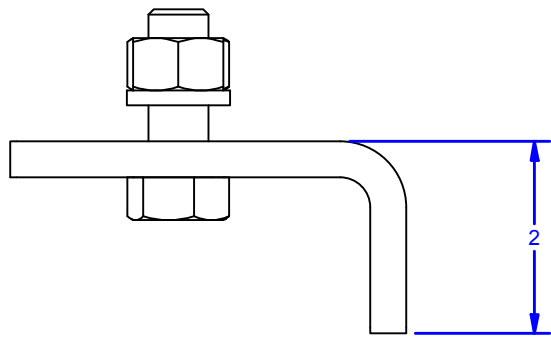

(2 ea.) HHMB 5/8-11 UNC - 1.75 Zinc -5
Hex Head Machine Bolt -Grade 5, Zinc
w/ Lock Washer & Nut

#102T Track

Flat Track Hanger
Contacts #102p87A Stop

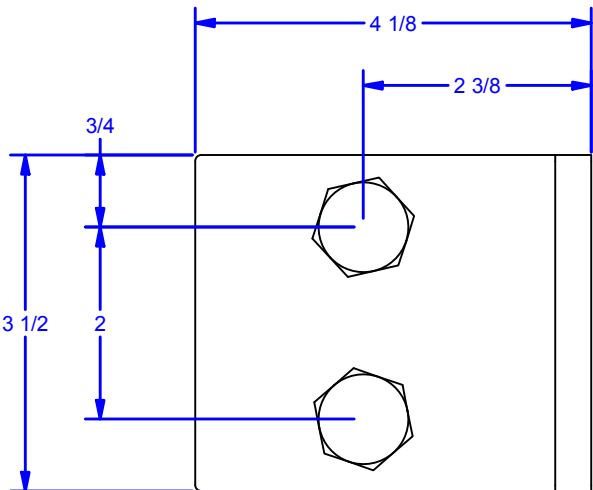
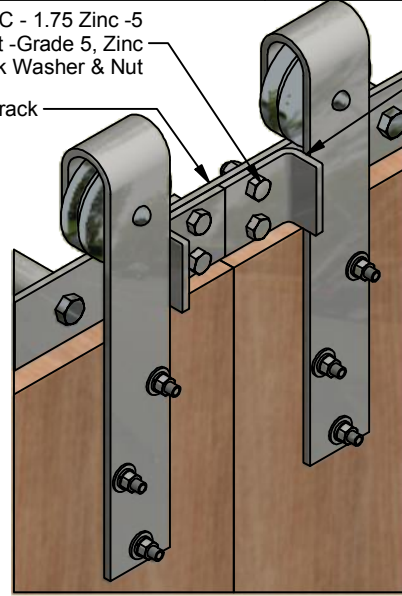
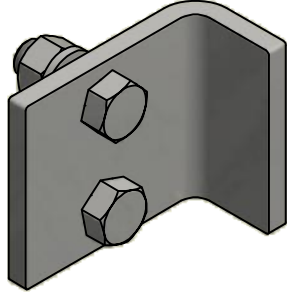

Bi-Parting Option

Flat Track Hanger
Contacts #102p87A Stop

2 Minimum

#102WS Wall Spacer
#102T Track

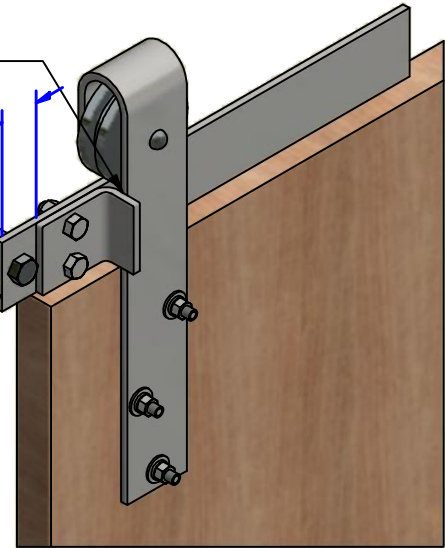

Single Slide Option

- Available Finishes:**
102P87A-B-BZ: Flat Black Painted with Black Zinc Fasteners
102P87A-B: Flat Black Painted with Clear Zinc Fasteners
102P87A-G: Hot Dipped Galvanized with Clear Zinc Fasteners
102P87A-C: Grounded Steel with Clear Coat Painted w. Clear Zinc Fasteners
102P87A-S: 304 Stainless Steel #4 Brushed Finish w. Stainless Steel Fasteners

DWG #: 0001544
 DRAWN:BCM 3/23/2016
 SHEET #14
 File: 0001544.idw

ALL DIMENSIONS IN INCHES		ID #:	STOCK PART #:
THE INFORMATION CONTAINED IN THIS DRAWING IS THE SOLE PROPERTY OF CROWN INDUSTRIAL. ANY REPRODUCTION IN PART OR AS A WHOLE WITHOUT THE WRITTEN PERMISSION OF CROWN INDUSTRIAL IS PROHIBITED.		0002255	102P87A
DESCRIPTION:		MATERIAL:	
End Stop Bumper (Biparting)			
FINISH:	# PCS:	REV:	

CROWN INDUSTRIAL
 So. San Francisco, Ca
 (650) 952-5150
 www.crown-industrial.com

4

3

2

1

