

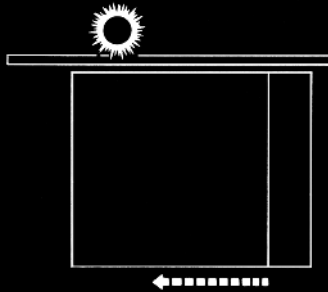

*Read  
This  
FIRST*



**GENERAL  
INSTALLATION,  
OPERATION,  
MAINTENANCE,  
and PARTS MANUAL  
for your**

**1265XHD DC  
SLIDE DOOR OPERATOR  
Model Extra Heavy Duty DC**

Copyright © Crown Industrial Operators 2011

**Crown Industrial Operators**  
(Formerly manufactured by Richards-Wilcox)  
213 Michelle Court  
So. San Francisco, CA 94080  
Phone (650) 952-5150  
Fax (650) 873-1495  
website: [www.crown-industrial.com](http://www.crown-industrial.com)

**G-998**

## Table of Contents

1) INTRODUCTION.....	3
A) Purpose .....	3
B) Models Covered .....	3
C) Application.....	3
D) Description .....	3
2) INSTALLATION .....	3
A) General.....	3
B) Installation of the 1265XHD-DC Motor Unit .....	4
C) Installation of Idler .....	4
D) Installation of Chain Disconnect.....	4
E) Installation of Drive Chain .....	5
Electrical Wiring .....	MDC1
Door Direction - DC Motor Rotation.....	MDC1
Vent Plug Installation .....	VP1
Clutch/Torque Limiter Adjustment .....	TL1
Rotary Limit Switch Setup.....	LS1-3
DC Drive Controller RUN/CREEP Settings .....	DC1-3
3) MAINTENANCE for Sliding Door Operators.....	SM1
A) General.....	SM1
B) Preventative Maintenance.....	SM1
4) PARTS .....	PL1
A) To Order Replacement Parts .....	PL1
5) WARRANTY .....	W1

Note: We reserve the right to modify or change, without prior notice, any statements or information contained herein. If exact dimensions or specifications are required by the customer certified prints will be furnished without charge upon request to Crown Industrial. This manual covers standard catalogued operators only and does not cover special non-standard equipment.

## 1. INTRODUCTION

**A. PURPOSE:** This Crown Installation, Operation, Maintenance and Parts Manual has been developed to assist you in the installation, operation and maintenance of your electric operator and thus enable you to utilize it to its maximum efficiency.

**B. MODELS COVERED:** The manual covers current models 1265XHD-DC Operator.

**C. APPLICATION:** The Crown Industrial Model #1265XHD-DC Sliding Door Operator is intended for use on large interior industrial doors operated by trained personnel.

**D. DESCRIPTION:**

The model 1265XHD-DC operator consists of a DC permanent magnet gear motor, a safety friction disc clutch, right angle worm gear and a fully automatic rotary limit switch all assembled into a complete power drive chain unit assembly. Also included as part of the operator is a chain release door bracket, roller chain and an adjustable idler take up assembly as well as a remotely located control panel.

The control panel converts single phase AC line power to regulated DC power for adjustable speed control of the permanent magnet DC motor. The operator run speed and creep speed at the ends of the strokes are field adjustable as well as its acceleration and deceleration. By controlling the starting and stopping torque, this drastically improves the operator and hardware durability and dependability.

## 2. INSTALLATION AND OPERATION

### A. GENERAL

The Crown 1265XHD-DC Electric Door Operator has been designed primarily for industrial installations where the operator has to withstand constant hard use. To ensure correct installation and proper operation of the operator and associated hardware, the following instructions are given:

1) **SHIPMENT CHECK:** Included with the installation packet is a copy of the packing slip for the components supplied with the order. Compare the components received with the packing slip to insure that all equipment is complete.

2) **REVIEW INSTALLATION DRAWINGS:** The installation drawings show the layout of the door, the operator, electrical wiring connections, and general terms used to describe the components. Review the drawings to familiarize yourself with the equipment. To determine the hand of the single slide doors for operator mounting purposes, stand on the door side of the wall facing through the door opening. If the door slides to your right, it is a right-hand door. (Reference Figure 1 Single Slide Door.)

3) **CHECK THE DOORS:** After installation of door and track and before starting operator installation, inspect to ensure the door and sliding door hardware is in good working operation, is rigidly supported and has no obstruction to block or retard its slide. Sliding door track should be installed level and the door should be plum, balanced, and slides smoothly. Additionally, check that there is adequate clearance between the bottom of the door and the floor.

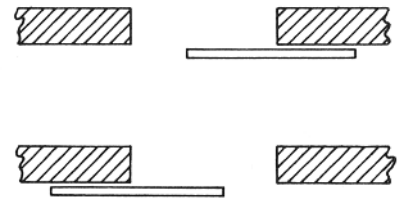

**Figure 1. Single Slide Door**

**B. INSTALLATION OF THE 1265XHD-DC MOTOR UNIT**

The operator motor unit should be mounted at the correct elevation in relationship to the top of door. The drive sprocket on this unit should align with the proposed location of the #1250.00116 Heavy Duty Chain Disconnect. The unit should be positioned correctly in relation to the opening and the direction of travel of the door.

**C. INSTALLATION OF IDLER**

Purpose: Allows the loop of drive chain to be tightened.

If using #1265P773 Idler Mount Plate, install the #1265P753 Extra Heavy Duty Idler Assembly onto it. Ensure the orientation of the idler assembly is correct in relation to the Operator Motor Unit. The Heavy Duty Idler Assembly should be fully extended so that, once the chain is installed, it can be tightened and the slack in the drive chain is taken up.

**Note:** Ensure there will be sufficient clearance between the Heavy Duty Chain Disconnect and the Idler as well as the Operator Motor drive sprocket when the door is in both the fully closed and fully open positions.

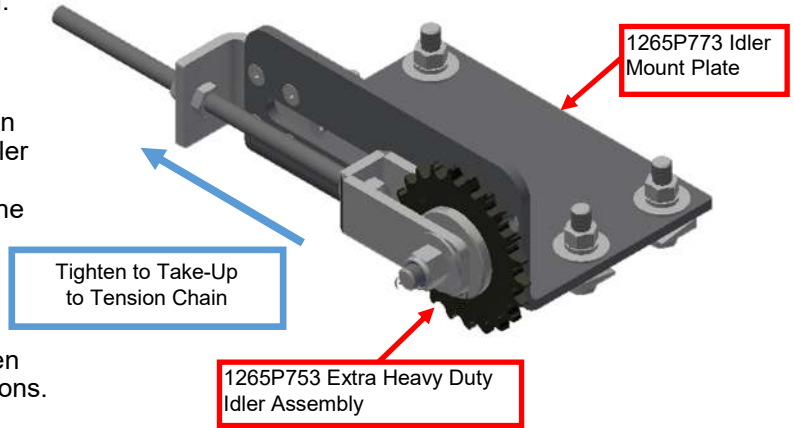

**Figure C.1  
Idler Assembly**

**D. INSTALLATION OF 1250.00116 HEAVY DUTY CHAIN DISCONNECT**

Purpose: The chain disconnect is used to attach the door to the roller chain allowing the operator to move the door back and forth. In the event of an emergency, the Heavy Duty Chain Disconnect is spring-loaded and features a pull chain that disengages the disconnect from the loop of drive chain (Figure D.1). For the system to return to normal operation, the Heavy Duty Chain Disconnect must be aligned and re-engaged with the 1250P141 long link assembly (Figure D.2) in drive chain loop.

The Heavy Duty Chain Disconnect can be either bolted to a shim plate that is welded to side plate of the I-Beam Trolley or attached directly to the door using a bracket. The chain disconnect is to be installed such that the chain remains straight and level and in plane with the bottom of the idler sprocket and drive sprocket at the motor unit.



**Figure D.2  
1250P141  
#60 Long Link Assembly**

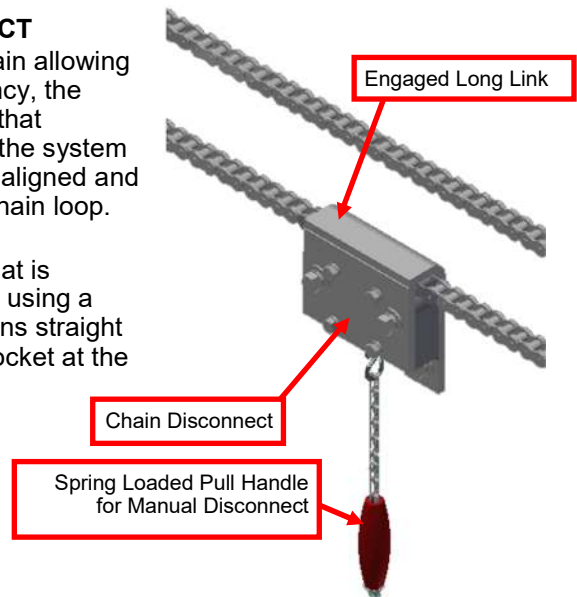

**Figure D.1  
Chain Disconnect**

### **E. INSTALL LOOP OF #60 DRIVE CHAIN**

- 1) Move the door into the full open position and shim into place so it cannot move.
  - 2) Connect one end of drive chain to the #1250P141 Long Link Assembly. This connection should be made closest to the Operator Motor Unit.
  - 3) Feed the chain around the drive sprocket of the Operator Motor Unit, then down and around the #1265P753 idler. Continue the chain back to the other end of the #1250P141 Long Link Assembly and connect it.
  - 4) Adjust the tautness of Drive Chain by adjusting the #1265P753 Extra Heavy Duty Idler Assembly. The chain should not be too tight or too loose. A proper tension should allow for approximately 1" of up-and-down movement.
- Note:** Chain Tension can shorten the life and cause extreme wear on the idler and drive sprockets. Conversely, a loose chain could jump the drive sprocket and jamb or change the door stopping points.



# CROWN INDUSTRIAL OPERATORS

## Door Hardware, Operators, and Complete Systems

### Electrical Wiring

This electric door operator is intended for application to motor branch circuits with voltage and current characteristics to meet operator ratings. Ensure input voltage and amperage match what is indicated on the wiring diagram for your specific unit. Branch circuit, branch circuit disconnecting means, and branch circuit overcurrent protection are to be properly sized in respect to the operator horsepower rating.

With power OFF, wire Operator Motor, Limit Switches, Actuator Controls and Safety Devices as shown on the wiring diagram provided in the operator packing list envelope or on the inside cover of the operator control box unit.

**Warning: Ensure operator branch circuit is disconnected from power source when installing, adjusting, or servicing operator.**

### Door Direction—DC Motor Rotation

Purpose: To determine if your door is moving in the correct direction and address the issue if it is not.

- 1) Ensure all controls are properly wired and connected along with safety devices.
- 2) Get familiar with the controls of the unit. Ensure you understand how the controls run and stop the Operator Motor Unit.
- 3) Turn Off Power to Operator Motor Unit but switching off the power disconnect at the operator control box.
- 4) Loosen all bolts on the Operator Clutch or Torque Limiter so the drive sprocket is free to rotate with the roller chain, when the Operator Motor Unit is not running. The door should be free to move by hand.
- 5) Identify which direction the gearbox output shaft needs to spin in order for the door to open.
- 6) Restore power to the Operator Motor Unit.
- 7) Activate the actuator to cause an "open" signal. DOES THE GEARBOX TURN IN THE CORRECT DIRECTION as identified in step #5?
- 8) If "NO"
  - A) Turn off Power to the Control Box.
  - B) Switch the motor lead wires typically labeled "A1" and "A2" located on the terminal strip in the control box.
  - C) Restore power and confirm direction of rotation at the gearbox is correct.
  - D) Tighten all bolts on the Operator Clutch or Torque Limiter.

Crown Industrial • 213 Michelle Ct. • So. San Francisco, Ca 94080-6202

Phone: (650) 952-5150 • Fax: (650) 873-1495

www.crown-industrial.com Email: autodor@crown-industrial.com

MDC1

11-20-24



# CROWN INDUSTRIAL OPERATORS

## Vent Plug

Door Hardware, Operators, and Complete Systems



**Figure VP2**

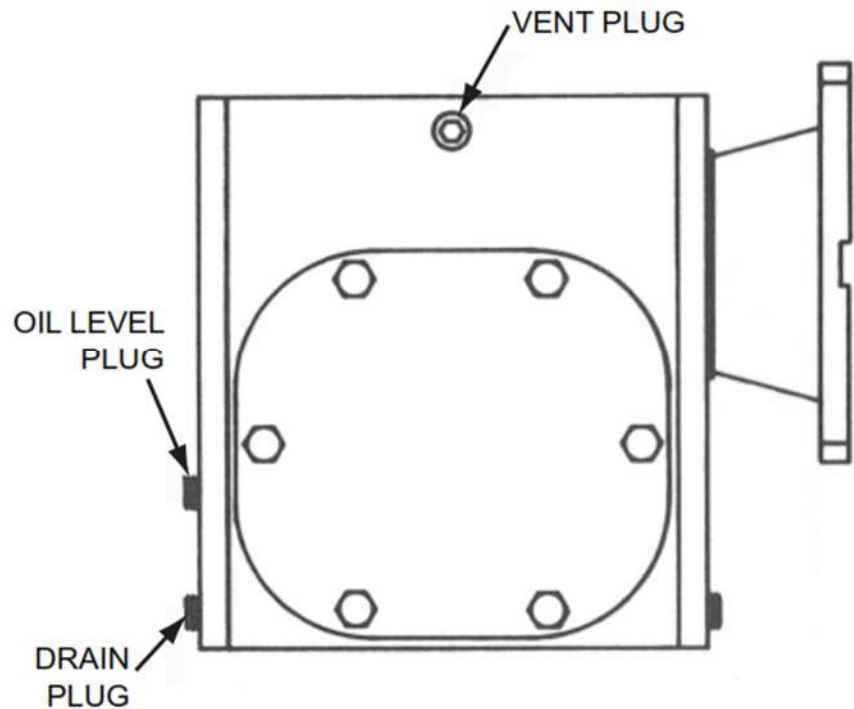

**Figure VP1**

Once the operator/gearbox is positioned correctly and installed, remove the 1/2" NPT steel pipe plug located nearest the top of the gearbox (Figure VP1) and replace it with the blue plastic vent plug (Figure VP2) provided with the operator. The plastic vent plug allows for pressure equalization for the oil reserve inside of the gearbox.

### **Maintenance:**

The drive unit is pre-lubricated and shipped with Mobil "SHC 634" synthetic lubricant. This oil is a lifetime lubricant rated for operation in ambient temperatures ranging from -40°F to +125°F.

Every **6 Months** check the oil level by removing the oil level plug. The oil should be up to the bottom of the plug hole.



# CROWN INDUSTRIAL OPERATORS

## Torque Limiter Adjustment

Door Hardware, Operators, and Complete Systems

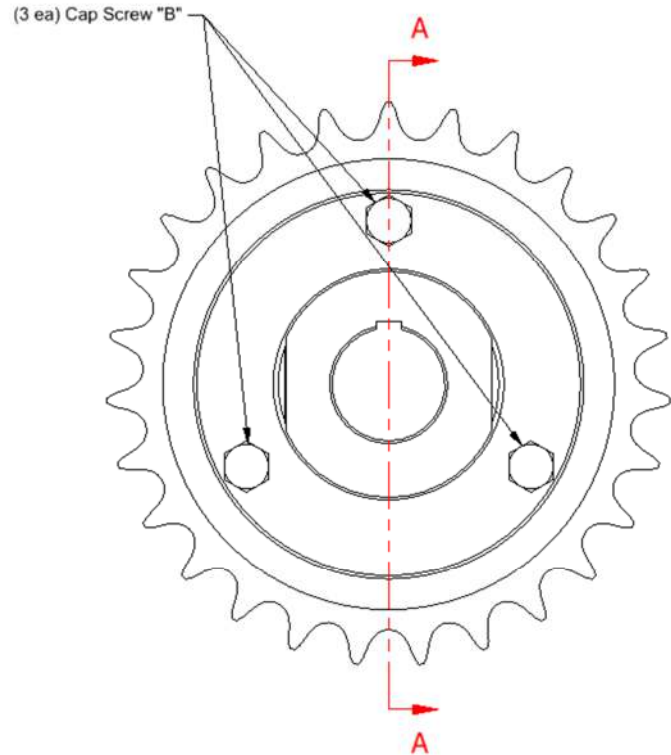
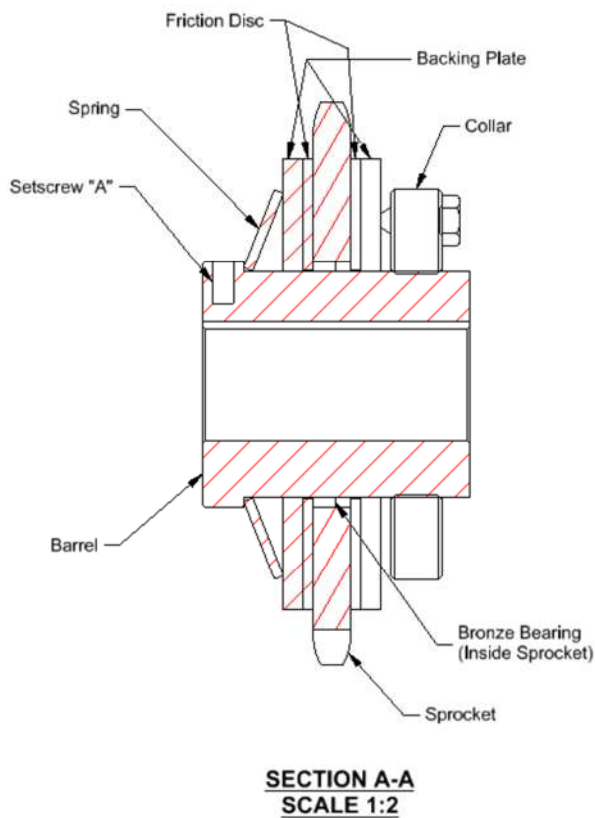

**Figure TL1**

**WARNING:** Disconnect power before installation or maintenance. Failure to do so may result in injury or death.

### **Purpose:**

The clutch (torque limiter) is used to protect the equipment from shock loads that might be introduced into the system. Under normal operation the clutch will not slip. Therefore the clutch should be adjusted to a sufficient torque that will allow the operator to start and stop the door without any slipping. Keep in mind the clutch should not be so tight that it cannot slip under excessive loads.

### **Tighten the clutch (torque limiter):**

- (1) Back off the three cap screws "B" as shown in Figure TL1 until the points are recessed in the threaded adjusting collar.
- (2) Tighten the collar by hand.
- (3) Tighten cap screws marked "B" as shown in Figure TL1 until the heads of the cap screws bottom out against the collar.





# CROWN INDUSTRIAL OPERATORS

## Rotary Limit Switch Setup

Door Hardware, Operators, and Complete Systems

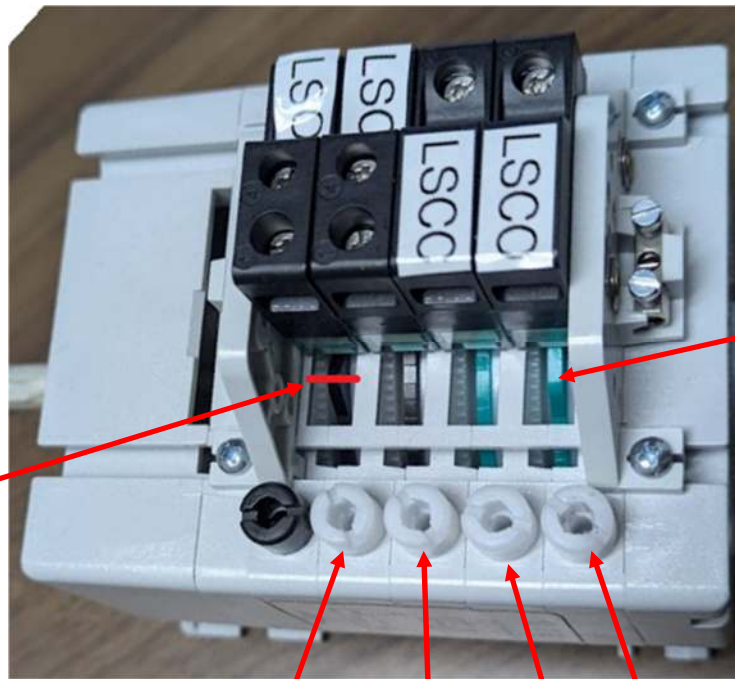

Black Colored, Short Cam of an Open or Close Limit

Teal Colored, Long Cam of a Creep Limit

Adjusting Screw for LSO Limit Switch

Adjusting Screw for LSCO Limit Switch

Adjusting Screw for LSC Limit Switch

Adjusting Screw for LSCC Limit Switch

**Figure LS1**

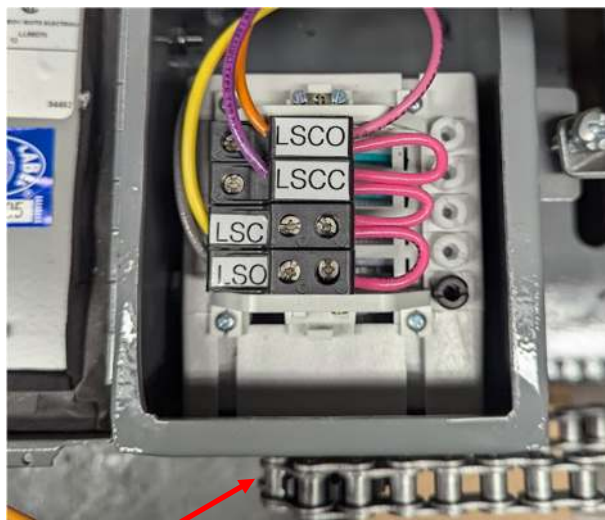

Limit switch shaft with limit switch sprocket

**Figure LS2**



# CROWN INDUSTRIAL OPERATORS

## Rotary Limit Switch Setup

Door Hardware, Operators, and Complete Systems

### Purpose:

To set the full Open (LSO), Close (LSC), Creep Open (LSCO) and Creep Close (LSCC) limits of your operator.

- Limit Switch Open (LSO): defines where your door will stop in the full open position.
- Limit Switch Close (LSC): defines where your door will stop in the full closed position.
- Limit Switch Creep Open (LSCO): This limit activates the creep mode during the end of the open cycle. When the limit switch is actuated the door travels in the opening direction at a reduced speed set by the Creep Potentiometer in the Control Box.
- Limit Switch Creep Open (LSCC): This limit activates the creep mode during the end of the close cycle. When the limit switch is actuated the door travels in the closing direction at a reduced speed set by the **Creep Potentiometer in the Control Box.**

### Description:

The rotary limit switch is designed to accurately control the end limits of the door travel provided by the electric operator as well as the activation point and duration of the creep mode. The limit switch input shaft drives a set of planetary gears which in turn drives a set of nylon cams (See Figure LS1). Each precision limit switch unit is actuated by its individual nylon cam. The cam rotate as the operator travels the door back and forth. The cam contacts the electrical snap switches to either stop the travel of the operator or initiate the creep modes. The limit switch typically has 4 switches.

To adjust each individual limit switch, turn the screw adjustment for each specific limit switch. Note that depending upon the handing of the operator the cams travel from either the clockwise or counterclockwise direction to activate the appropriate snap switches.

Limit Switch Adjustment	Limit Switch Adjusting Screw Rotation Direction			
	LSO (Limit Switch Open)	LSC (Limit Switch Close)	LSCO (Limit Switch Creep Open)	LSCC (Limit Switch Creep Close)
Rotates <u>Counter Clockwise</u> to Open	<u>Counter Clockwise</u> to Open More	Clockwise to Close More	Clockwise to Creep Open Longer	<u>Counter Clockwise</u> to Creep Close Longer
Rotates <u>Clockwise</u> to Open	Clockwise to Open More	<u>Counter Clockwise</u> to Close More	<u>Counter Clockwise</u> to Creep Open Longer	Clockwise to Creep Close Longer

Table LS T1



# CROWN INDUSTRIAL OPERATORS

## Rotary Limit Switch Setup

### Door Hardware, Operators, and Complete Systems

#### **Preliminary Rotary Limit Switch Adjustment:**

##### 1. PREPARATION FOR ADJUSTMENT:

- a. Disconnect the Electrical Power Supply to the Operator Control Box.
- b. Unscrew limit switch cover and expose assembly.

##### 2. ROUGH ADJUSTMENT:

- a. Manually Slide or Swing the door in the open direction and note the direction the Limit Switch Sprocket is rotating. Is it turning clockwise or counterclockwise? Reference **Table LS T1**.
- b. Manually Slide or Swing the door to approximately 6" from the full open position.
- c. Adjust the LSO cam adjuster until the cam contacts the electrical snap switch from the same direction and you hear it click.
- d. Manually Slide or Swing the door towards the closed direction and back towards the open direction. The snap switch should click when the door gets approx. 6" from the full open position.
- e. Position the door approx. 12" from the full open position.
- f. Turn the LSCO cam adjusting screw until the cam contacts the electrical snap switch from the same direction as the LSO switch and you hear it click. **Note:** This cam is longer and the operator shall only travel in closed creep mode while this cam is depressing the snap switch.
- g. Repeat Step (d). The LSCO the snap switch should click when the door gets approx. 12" from the full open position.
- h. Manually Slide or Swing the door to approximately 6" from the full closed position.
- i. Turn the LSC adjusting screw until the cam contacts the electrical snap switch from the opposite direction and you hear it click.
- j. Manually Slide or Swing the door towards the open direction and back towards the closed direction. The snap switch should click when the door gets approx. 6" from the full closed position.
- k. Position the door approx. 12" from the fully closed position.
- l. Turn the LSCO cam adjusting screw until the cam contacts the electrical snap switch from the same direction as the LSC switch and you hear it click. **Note:** This cam is longer and the operator shall only travel in open creep mode while the cam is depressing the snap switch.
- m. Repeat step (j) LSCO the snap switch should click when the door gets approx. 12" from the full open position.
- n. Move the door back and forth noting that the proper snap switches are being contacted from the proper direction at the proper time.

#### **Final Rotary Limit Switch Adjustment:**

After the run speed, creep speed and ACCEL & DECEL have been adjusted, the final limit switch settings can be made.

- a. Actuate the operator controls and adjust the rotary limit switches (LSO & LSC) to stop the door in the full open and closed positions.
- b. Actuate the operator and adjust the rotary limit switches (LSCO & LSCC) to initiate the creep mode at the desired time. Keep in mind that the operator only travels in creep mode as long as the cam lobe is depressing the snap switch.
- c. After adjusting LSCO & LSCC check the travel of the door. LSC & LSO may need to be re-adjusted.
- d. Activate the operator to open and close the door several times and fine tune the limit switches.

**Note:** The length of time the operator is running in creep mode must be long enough to allow for it to dynamically brake from run speed to creep speed plus the desired length of time the operator is traveling under creep mode. If the DECEL time is set for too long, the creep mode may be adversely affected.



# CROWN INDUSTRIAL OPERATORS

Door Hardware, Operators, and Complete Systems

## 3. MAINTENANCE for Sliding Door Operators

### A. GENERAL

To insure the operator is ready for operation at all times, it must be inspected systematically at least **EVERY 6 Months**. Proper adjustment and lubrication must be maintained and checked as recommended below.

### B. PREVENTATIVE MAINTENANCE

#### 1) Gearbox Lubrication:

The drive unit is pre-lubricated and shipped with Mobil "SHC 634" synthetic lubricant. This oil is a lifetime lubricant rated for operation in ambient temperatures ranging from  $-40^{\circ}\text{F}$  to  $+125^{\circ}\text{F}$ . Every **6 Months** check the oil level by removing the blue plastic oil level vent plug. The oil should be up to the bottom of the plug hole. Reference Vent Plug Installation, sheet VP1 section of this manual for any additional information.

#### 2) Chain Lubrication:

Every 900 cycles, where one cycle consists of opening and closing of the door, or every **6 months**, whichever comes first, clean and lubricate the roller drive chain with a SAE lubricant as required for the ambient temperature.

#### 3) Check Tension of Chain:

Overtime the drive roller chain may stretch and must be retightened. Move the door until it is into the full open position. Go to the middle of the chain and confirm the slack of the chain allows a net up/down movement of approximately 1". Take care to not overtighten roller chain. The slack of the chain can be taken out at the chain idler which is located at the opposite end to the operator.

#### 4) Check Electrical Components & Wiring:

Ensure all electrical components are and wiring for tightness. Check battery life on all battery operated components such as wireless safety devices.

#### 5) Check Clutch/Torque Limiter:

Reference Clutch/Torque Limiter Adjustment on Sheet TL1 to confirm the tightness. Confirm clutch does not slip under normal condition.

#### 6) Check Sprockets & Sprocket Keys:

Check the wear on sprocket teeth. Ensure set screws are tight and secured in place using Blue Loctite. Check condition of keys of sprockets.

#### 7) Check All Bolts & Nuts for Tightness



# CROWN INDUSTRIAL OPERATORS

## 1265XHD PARTS

Door Hardware, Operators, and Complete Systems

### 4. PARTS

#### A. TO ORDER REPLACEMENT PARTS

Order all replacement parts using the number shown on the following parts list pages.

##### 1) Identify Serial Number & Model Number

Located the serial number and confirm the model number as located on the identification plate on the motor unit.



Example of Identification Plate

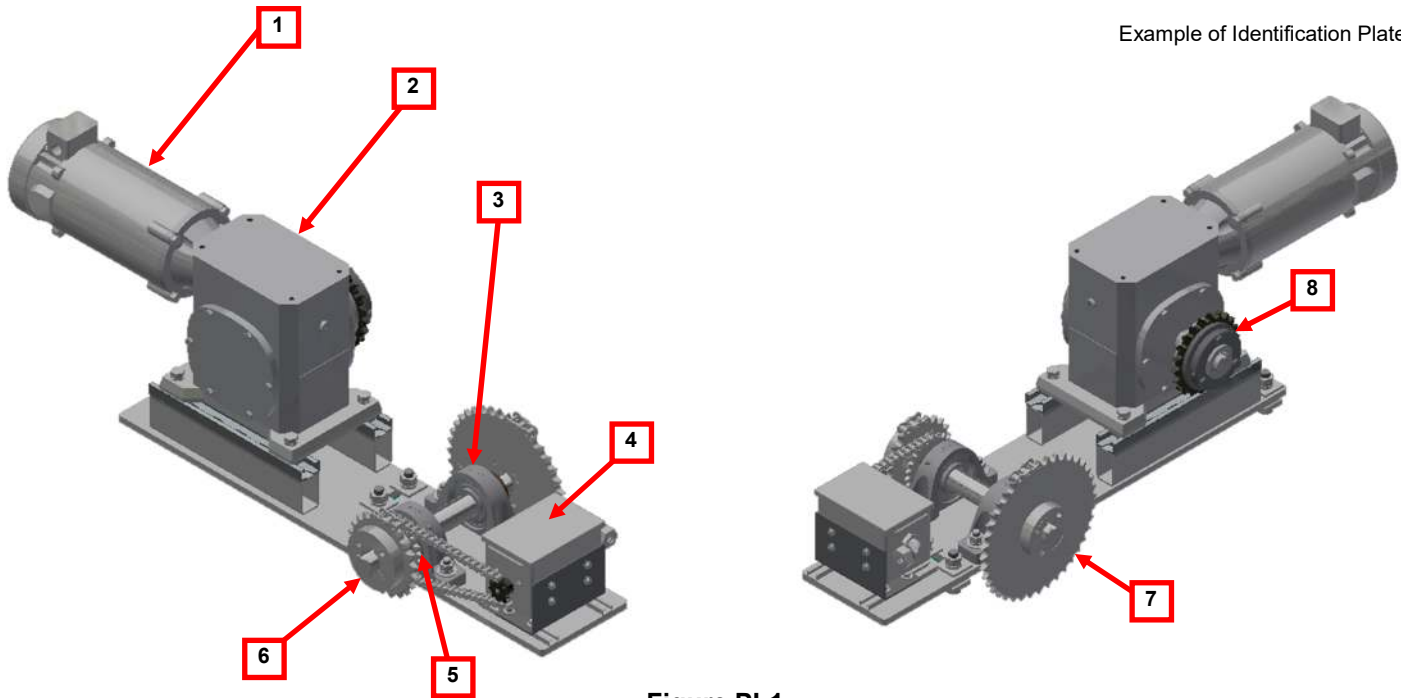

Figure PL1.  
Motor Unit

Identifier Number	Description
1	DC Motor
2	Gearbox (Speed Reducer)
3	Pillow Block
4	Limit Switch
5	Timing Sprocket
6	Drive Sprocket
7	Driven Sprocket
8	Clutch (Torque Limiter)



# CROWN INDUSTRIAL OPERATORS 1265XHD PARTS

Door Hardware, Operators, and Complete Systems

Identifier Number	Description
1	Idler Sprocket Assembly
2	Clevis
3	Idler Mount Plate

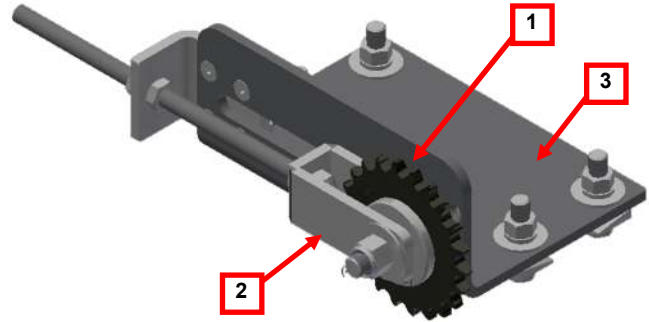

**Figure PL2.  
Idler Assembly**



**CROWN INDUSTRIAL OPERATORS**  
**Warranty**  
 Door Hardware, Operators, and Complete Systems

**MAINTENANCE INFORMATION**

(To Be Filled Out By User)

Operator Serial Number \_\_\_\_\_ H.P. \_\_\_\_\_

Supplied on Crown Industrial Operators Order Number \_\_\_\_\_

Power Supply \_\_\_\_\_ Volts \_\_\_\_\_ Hz \_\_\_\_\_ Phase \_\_\_\_\_

Installed At \_\_\_\_\_ Date \_\_\_\_\_

Notes \_\_\_\_\_

\_\_\_\_\_  
 \_\_\_\_\_  
 \_\_\_\_\_

**GUARANTEE**

If, within a period of one year from date of shipment, any part of a CIO Electric "Aut-o-doR" Operator is found defective due to poor materials or workmanship, new parts will be furnished free of charge F.O.B. manufacturer's plant, providing the equipment has been given normal and proper usage, lubrication, and maintenance and is still the property of the original purchaser and/or part of the original installation. *THIS WARRANTY IS GIVEN IN LIEU OF ALL OTHER WARRANTIES, EXPRESSED OR IMPLIED, AND THE MANUFACTURER MAKES NO IMPLIED WARRANTY OF MERCHANTABILITY BEYOND THE EXPRESSED TERMS HEREOF. MANUFACTURER'S LIABILITY FOR DAMAGES, INCLUDING CONSEQUENTIAL DAMAGES RESULTING FROM ANY SUCH DEFECTIVE PRODUCT IS STRICTLY LIMITED TO THE DELIVERY OF NEW PARTS, AS SET FORTH ABOVE.*