

Parts List			
ITEM	QTY	PART #	DESCRIPTION
1	1	0001044	Latch-Handle assembly
2	1	0001060	Latch Keeper, R.H.
3	1	0001060_MIR	Latch Keeper, L.H.
4	1	0001048	Latch Mount Retainer Back Plate
5	1	0001049	Latch Mount Retainer Top Plate
6	1	0001046	Latch Cam
7	1	0001747	Flush Pull Assembly
8	8	FHPSMS No. 10-16 x 1	Flat Head Phillips Sheet Metal Screw
9	4	FHPSMS No. 6-20 x 3/4	Flat Head Phillips Sheet Metal Screw
10	1	(FHPHMS) 3/8-16 x 2	Flat Head Phillips Head Machine Screw
11	3	3/8-16 UNC - 2.5	Short Neck Carriage Bolt
12	4	FW 3/8 - Regular - Type B	Flat Washer
13	4	3/8 LW	Lock Washer
14	4	N 3/8 - 16	Hex Nut - Grade 5
17	1	0000482	Padlock (By Others)

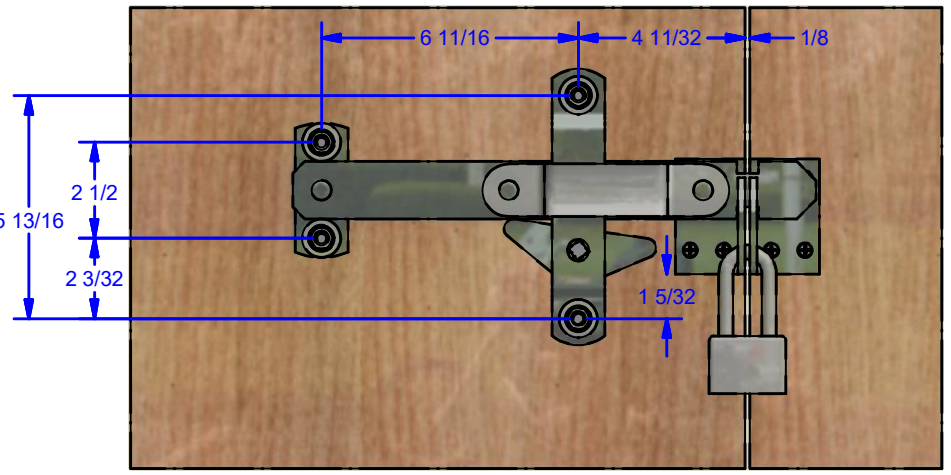

**Non-Wall Elevation**

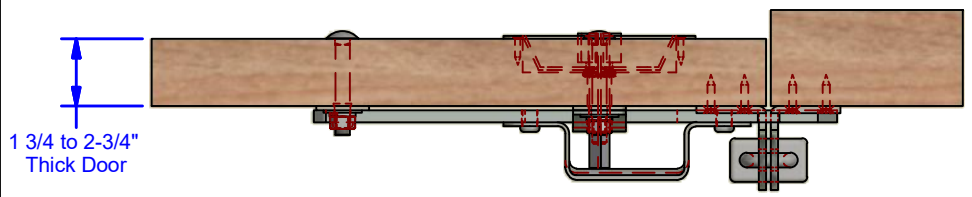
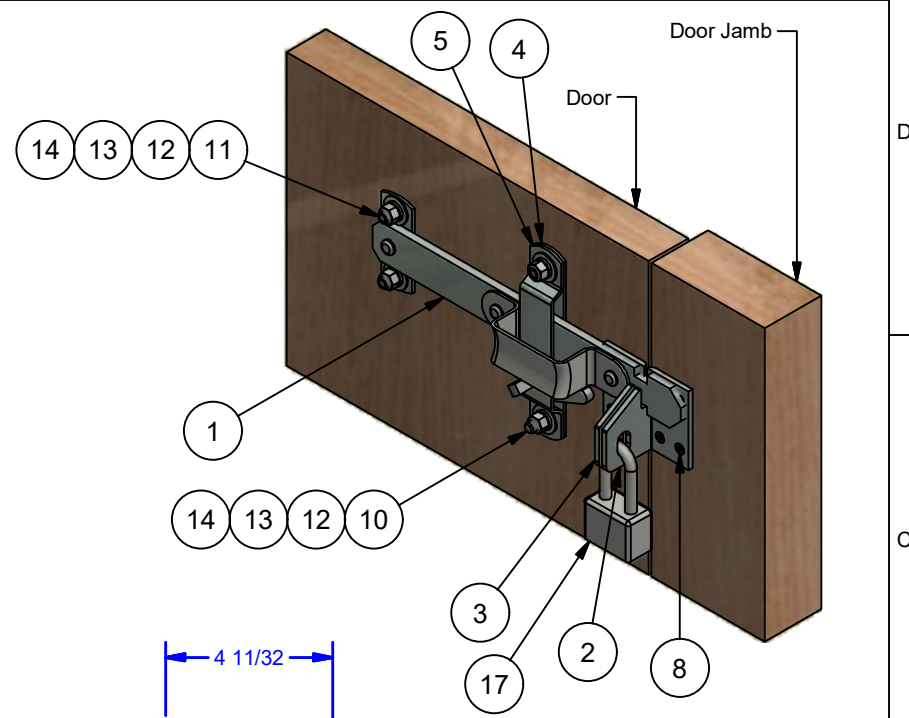
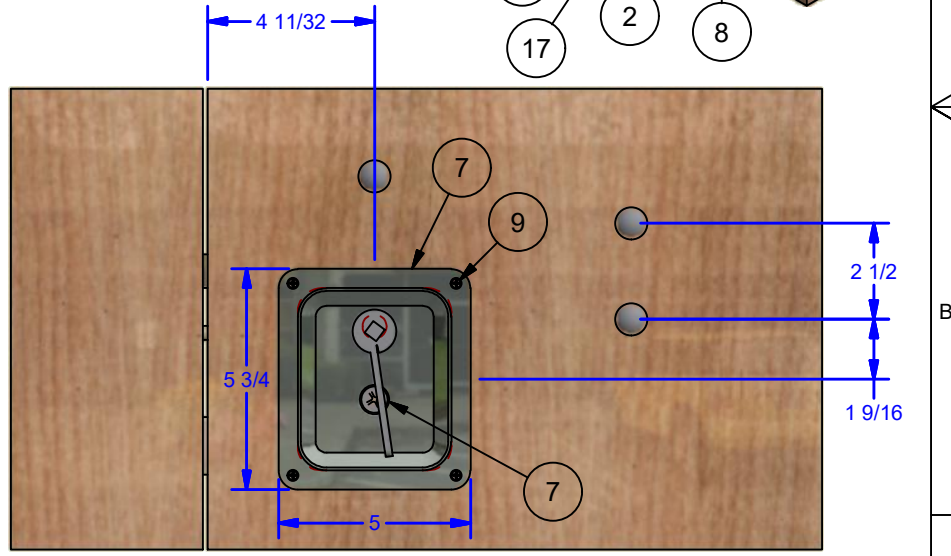

**Wall / Secure Elevation**

**FASTENERS NOT INCLUDED**

**ALL DIMENSIONS IN INCHES**

THE INFORMATION CONTAINED IN THIS DRAWING IS THE SOLE PROPERTY OF CROWN INDUSTRIAL. ANY REPRODUCTION IN PART OR AS A WHOLE WITHOUT THE WRITTEN PERMISSION OF CROWN INDUSTRIAL IS PROHIBITED.	ID #:	0001043	STOCK PART #:	0152.00023
	MATERIAL:			
DESCRIPTION:				
Door Latch (opens door from both sides)				
FINISH:			# PCS:	REV:
Clear Zinc				



**CROWN INDUSTRIAL**  
So. San Francisco, Ca  
(650) 952-5150  
www.crown-industrial.com

DWG #: 152P23  
DRAWN:BCM 6/6/2011  
SHEET #1  
File: 0001043.idw