

Parts List				
ITEM	QTY	PART #	DESCRIPTION	STOCK #
1	1	0000779	Center Pivot Top Plate	25B442CPT
2	2	0000373	Hanger Shaft	0000373
3	2	FHSCS 3/8-16 UNC x 1.5 Zinc	Flat Head Socket Cap Screw, Zinc	
4	2	0002870-06	Hanger Cross Shaft x 2"	
5	4	FHSCS 5/16-18 UNC x 1 Zinc	Flat Head Socket Cap Screw, Zinc	
6	1	0000774	#25 Top Swivel with Keeper	25B442SW

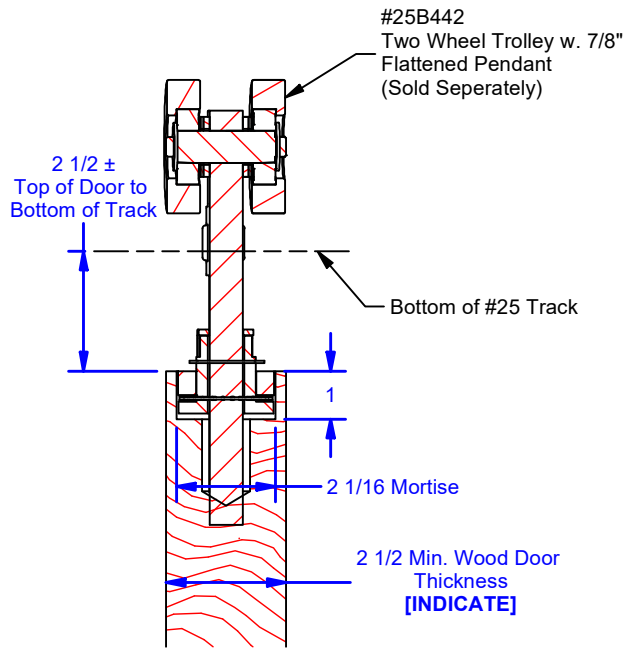

SECTION A-A
SCALE 1 / 4

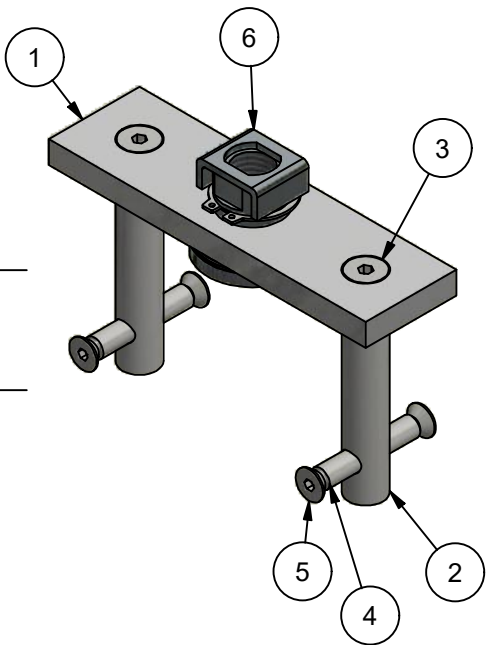
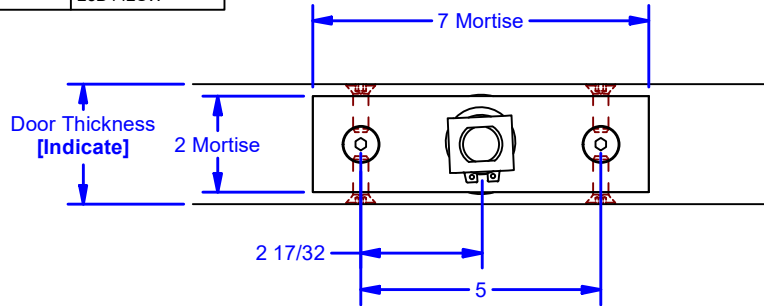
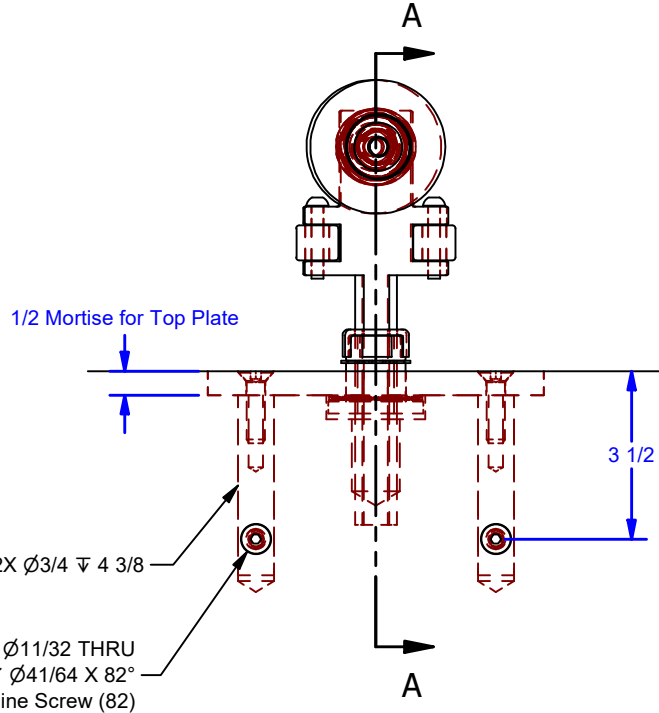

For 5/16 Flat Head Machine Screw (82)

ALL DIMENSIONS IN INCHES

THE INFORMATION CONTAINED IN THIS DRAWING IS THE SOLE PROPERTY OF CROWN INDUSTRIAL. ANY REPRODUCTION IN PART OR AS A WHOLE WITHOUT THE WRITTEN PERMISSION OF CROWN INDUSTRIAL IS PROHIBITED.	ID #:	0003063	STOCK PART #:	25B442SWTK-CH
	MATERIAL:			
DESCRIPTION: Center Hung Pivot: Keeper, Swivel & Top Plate				
FINISH: Clear Zinc			# PCS:	REV:



CROWN INDUSTRIAL
So. San Francisco, Ca
(650) 952-5150
www.crown-industrial.com