

Parts List				
ITEM	QTY	PART #	DESCRIPTION	STOCK #
1	1	0000456	Center Bracket	25x1
2	1	0000806	Joint Bracket Clip 25x39, 25x189	0000806
3	1	HN 3/4 - 10 Zinc-5	Hex Nut - Grade 5, Zinc	
4	1	HHMB 3/4-10 UNC - 1.25 Zinc -5	Hex Head Machine Bolt -Grade 5, Zinc	

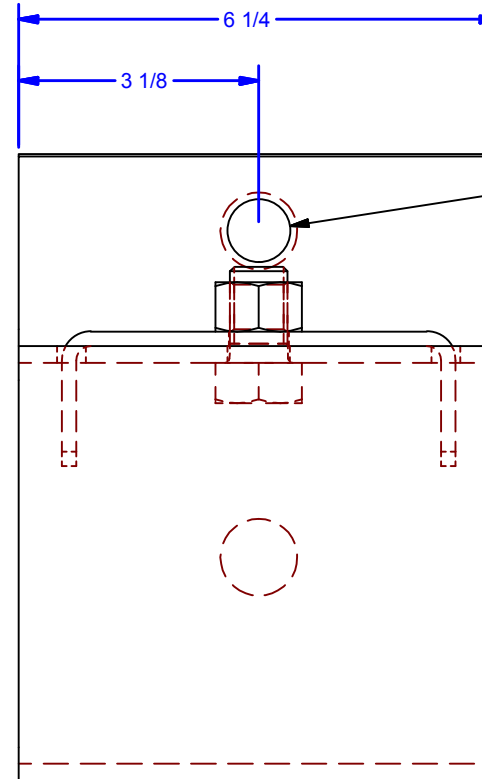
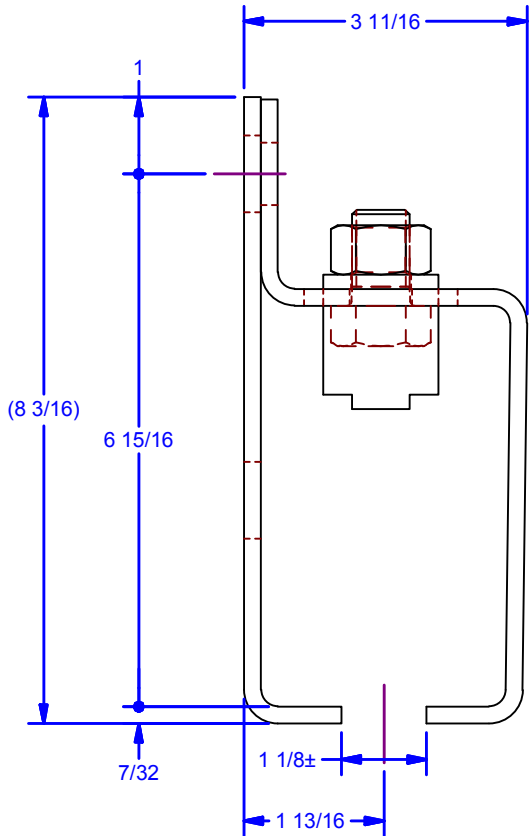
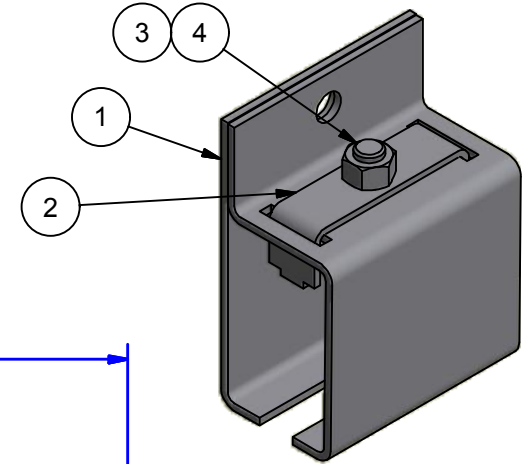

Ø13/16 THRU
For 3/4 Hex Head Bolt

Note:
For Joining Two Sections of Track Together
(in lieu of field welding tracks together)

DWG #: #25
DRAWN:BCM 2/7/2015
SHEET #5
File: 0000455.idw

ALL DIMENSIONS IN INCHES

THE INFORMATION CONTAINED IN THIS DRAWING IS THE SOLE PROPERTY OF CROWN INDUSTRIAL. ANY REPRODUCTION IN PART OR AS A WHOLE WITHOUT THE WRITTEN PERMISSION OF CROWN INDUSTRIAL IS PROHIBITED.	ID #:	0001851	STOCK PART #:	25x39
	MATERIAL:			
DESCRIPTION: Sidewall Joint Bracket				
FINISH:			# PCS:	REV:



CROWN INDUSTRIAL
So. San Francisco, Ca
(650) 952-5150
www.crown-industrial.com