

End View

Elevation View

Hood Stock Lengths
 296-7 x 4'
 296-7 x 8'
 296-7 x 10'

ALL DIMENSIONS IN INCHES

THE INFORMATION CONTAINED IN THIS DRAWING IS THE SOLE PROPERTY OF CROWN INDUSTRIAL. ANY REPRODUCTION IN PART OR AS A WHOLE WITHOUT THE WRITTEN PERMISSION OF CROWN INDUSTRIAL IS PROHIBITED.	ID #:	STOCK PART #:
	0000487	296-7
DESCRIPTION:	MATERIAL:	
Weather Hood Assy. for #6, #8, & #10 Track		
FINISH:	# PCS:	REV:
Galvanized		



CROWN INDUSTRIAL
 So. San Francisco, Ca
 (650) 952-5150
 www.crown-industrial.com

DWG #: 0000487
 DRAWN: BCM 9/17/2007
 SHEET #1
 File: 0000487.idw

4

3

2

1

D

D

C

C

B

B

A

A

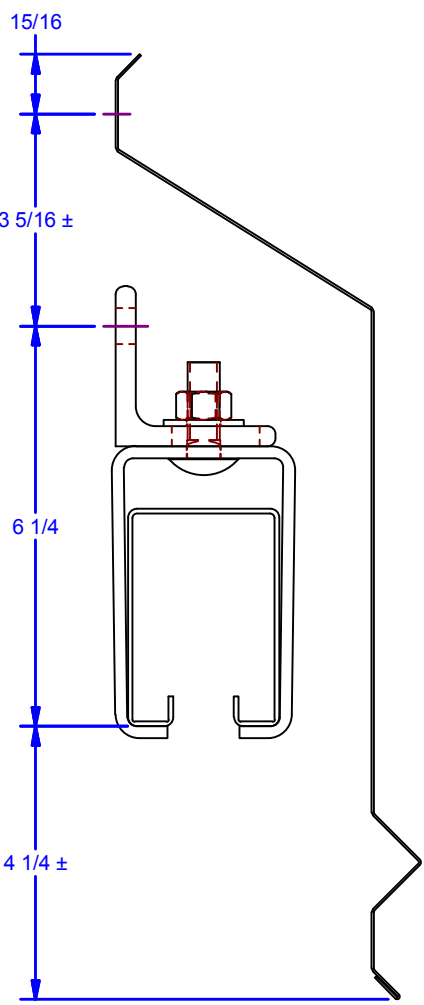

#6 Track

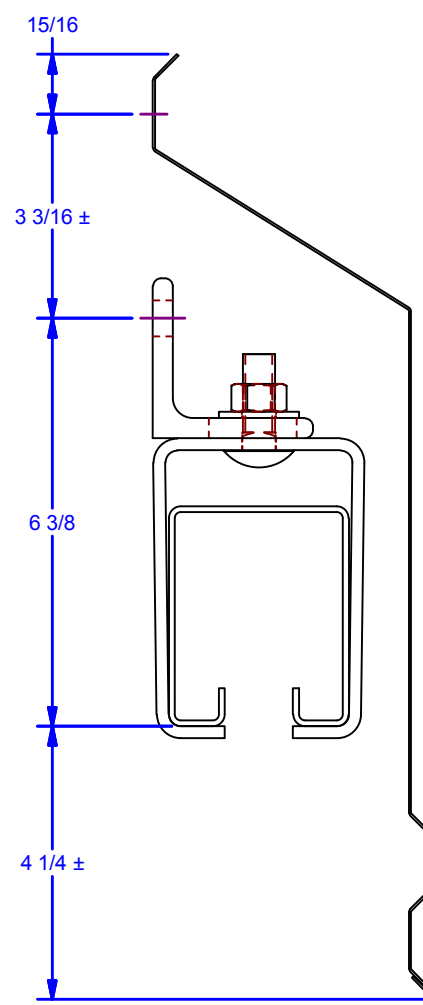

#8 Track

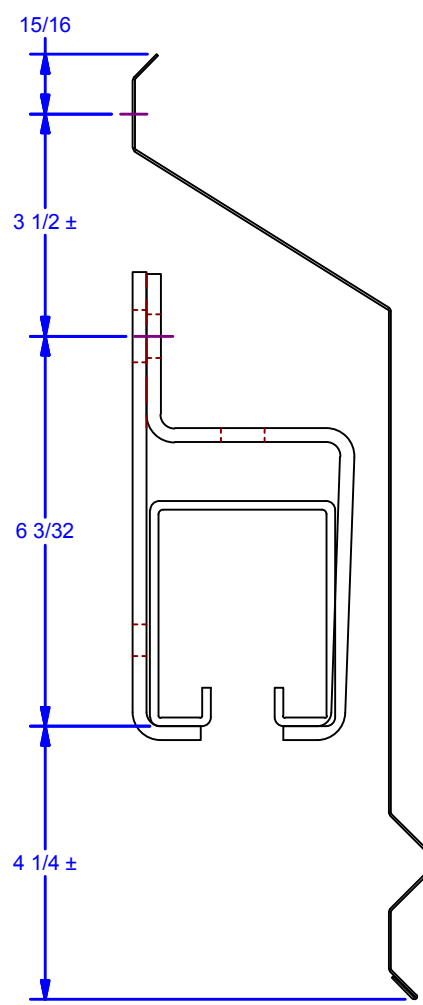

#10 Track

ALL DIMENSIONS IN INCHES

THE INFORMATION CONTAINED IN THIS DRAWING IS THE SOLE PROPERTY OF CROWN INDUSTRIAL. ANY REPRODUCTION IN PART OR AS A WHOLE WITHOUT THE WRITTEN PERMISSION OF CROWN INDUSTRIAL IS PROHIBITED.

ID #: 0002501

STOCK PART #:

MATERIAL:

DESCRIPTION:
Track w. 296-7 Hood Assembly

FINISH:

# PCS:	REV:
1	



CROWN INDUSTRIAL

So. San Francisco, Ca
(650) 952-5150

www.crown-industrial.com

DWG #: 0000487
DRAWN:BCM 6/20/2017
SHEET #2
File: 0000487.idw

4

3

2

1

