

4

3



2

1

D

D

C

C

B

B

A

A

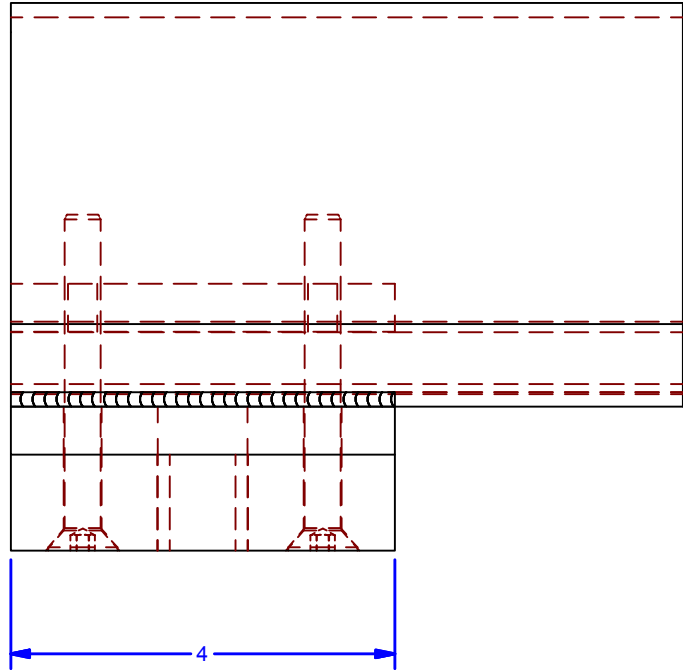
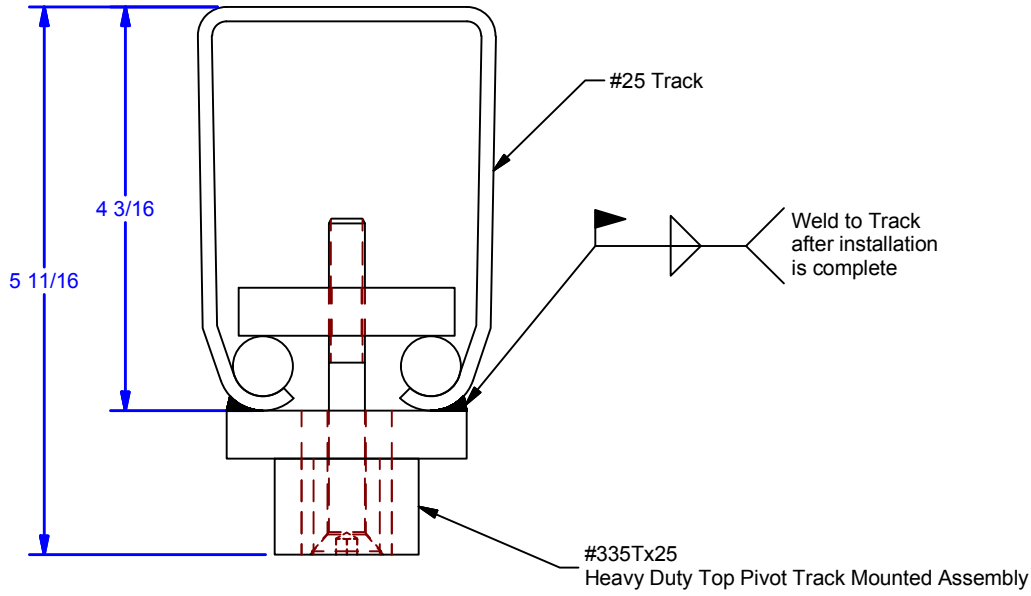
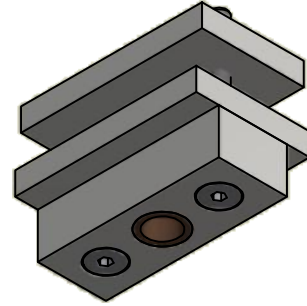

ALL DIMENSIONS IN INCHES

| | | | | |
|--|-----------|-------------------|---------------|---------|
| THE INFORMATION CONTAINED IN THIS DRAWING IS THE SOLE PROPERTY OF CROWN INDUSTRIAL. ANY REPRODUCTION IN PART OR AS A WHOLE WITHOUT THE WRITTEN PERMISSION OF CROWN INDUSTRIAL IS PROHIBITED. | ID #: | 0002170 | STOCK PART #: | 335TX25 |
| | MATERIAL: | Welded Steel Mild | | |
| DESCRIPTION: Heavy Duty Top Pivot Track Mounted Assy-Ptd. | | | | |
| FINISH: | Ptd. | | # PCS: | 1 |
| | | | REV: | |



CROWN INDUSTRIAL
 So. San Francisco, Ca
 (650) 952-5150
 www.crown-industrial.com

DWG #: 0002163
 DRAWN:BCM 12/18/2015
 SHEET #4
 File: 0002163.idw

4

3



2

1