

DWG #: 416
 DRAWN: BCM 2/19/2009
 SHEET #1
 File: 0000400.idw

ALL DIMENSIONS IN INCHES

THE INFORMATION CONTAINED IN THIS DRAWING IS THE SOLE PROPERTY OF CROWN INDUSTRIAL. ANY REPRODUCTION IN PART OR AS A WHOLE WITHOUT THE WRITTEN PERMISSION OF CROWN INDUSTRIAL IS PROHIBITED.	ID #:	0000400	STOCK PART #:	416
	MATERIAL:			
DESCRIPTION:				
416 Tite Tite Bolt				
FINISH:			# PCS:	REV:
Clear Zinc				



CROWN INDUSTRIAL
 So. San Francisco, Ca
 (650) 952-5150
 www.crown-industrial.com

4

3

2

1

Bipassing Set of Doors

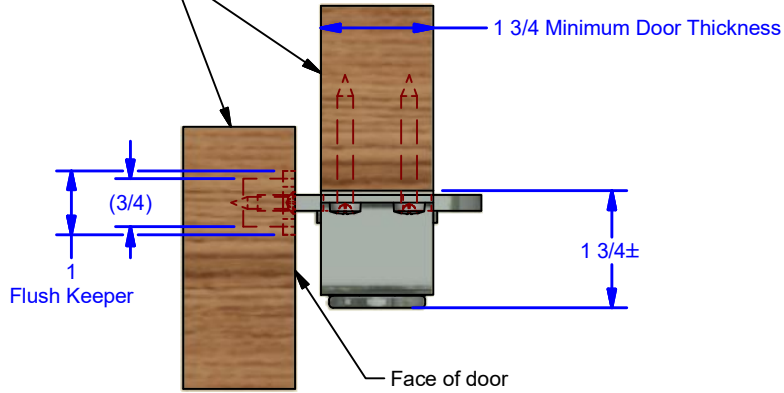

PLAN VIEW

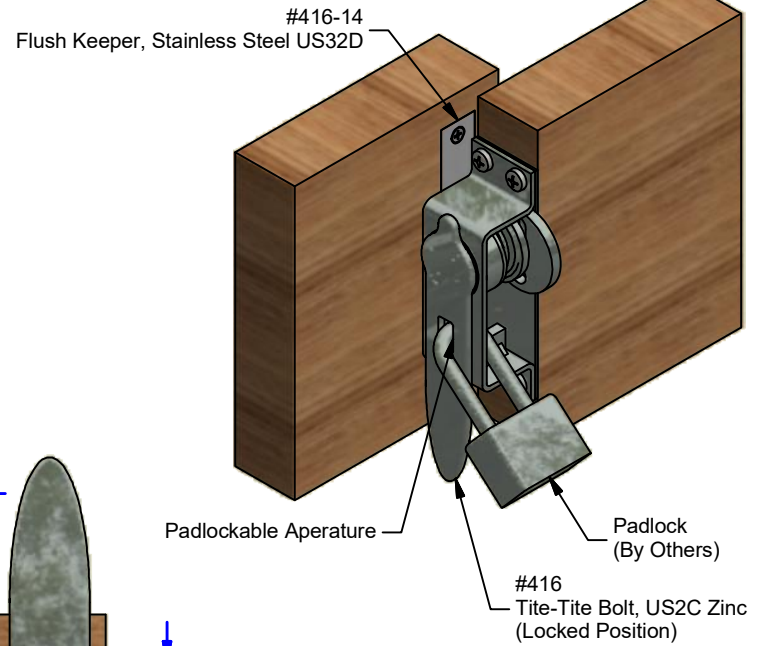

**END VIEW
UNLOCKED POSITION**

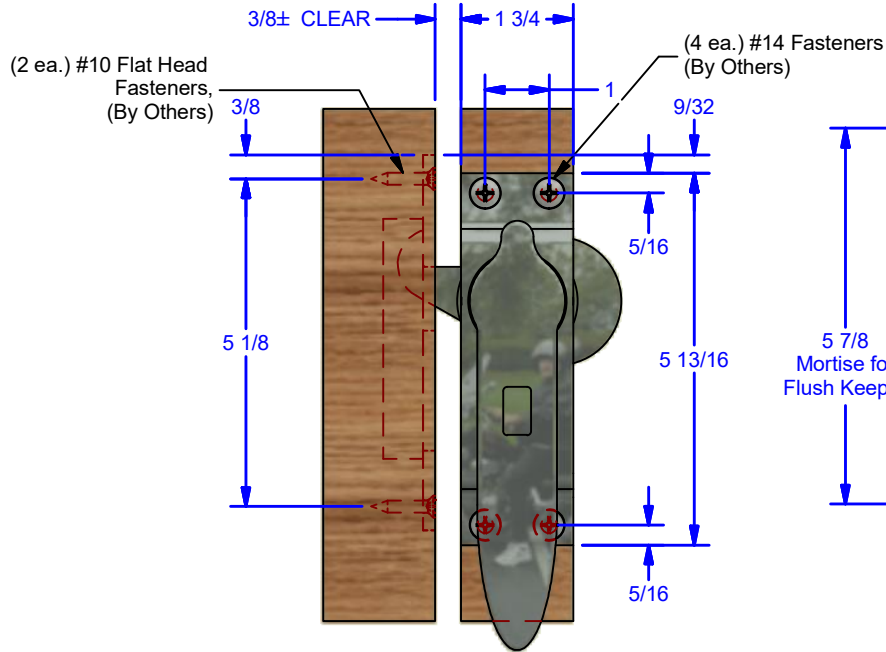

**END VIEW
LOCKED POSITION**

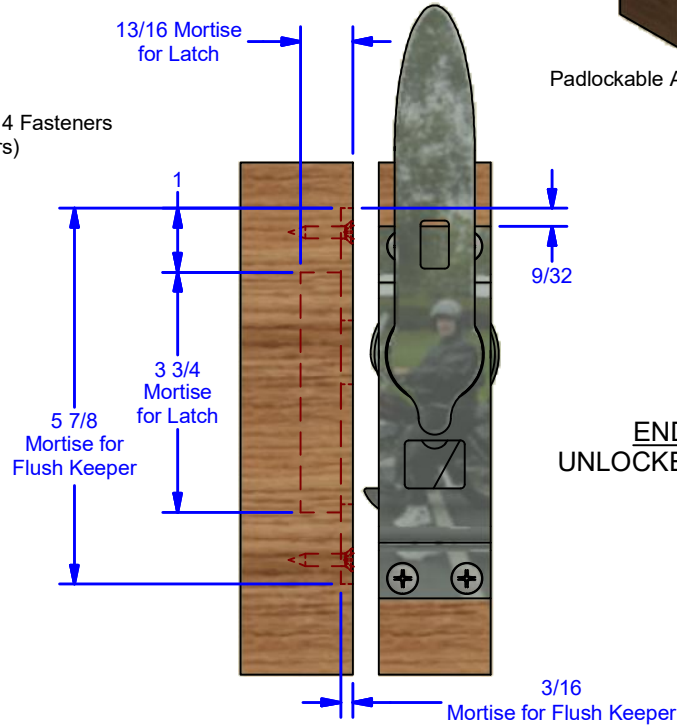

ALL FASTENERS BY OTHERS

ALL DIMENSIONS IN INCHES

THE INFORMATION CONTAINED IN THIS DRAWING IS THE SOLE PROPERTY OF CROWN INDUSTRIAL. ANY REPRODUCTION IN PART OR AS A WHOLE WITHOUT THE WRITTEN PERMISSION OF CROWN INDUSTRIAL IS PROHIBITED.

ID #:	0000415
MATERIAL:	

STOCK PART #:	416-1
---------------	-------

DESCRIPTION:
416 Tite Tite Bolt w/ 416-14 Flush Keeper, Bipassing Application

FINISH:	Clear Zinc	# PCS:		REV:	
---------	------------	--------	--	------	--



CROWN INDUSTRIAL
So. San Francisco, Ca
(650) 952-5150
www.crown-industrial.com

4

3

2

1

A

A

4

3



2

1

D

D

C

C

B

B

A

A

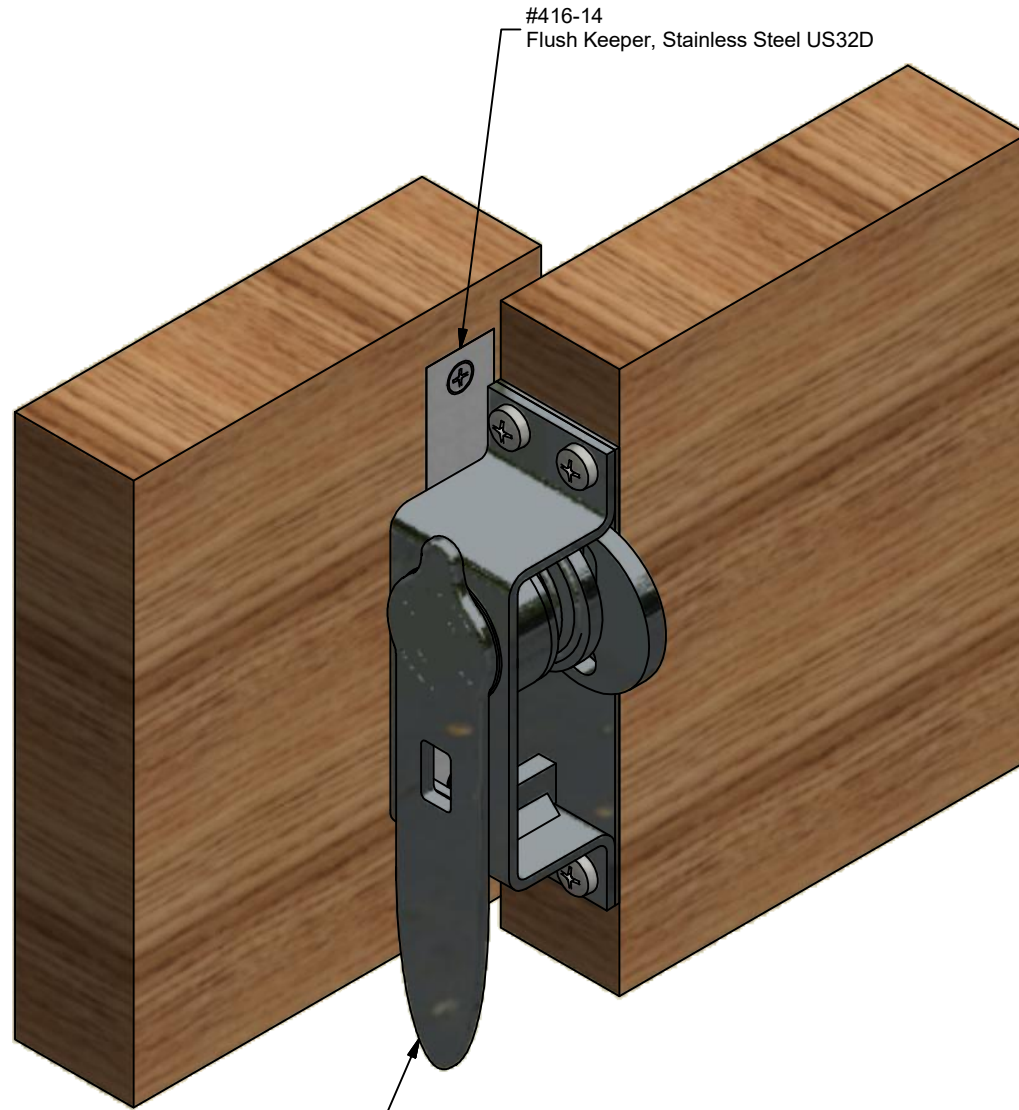

#416-14
Flush Keeper, Stainless Steel US32D

#416
Tite-Tite Bolt, US2C Zinc
(Locked Position)

ALL DIMENSIONS IN INCHES

THE INFORMATION CONTAINED IN THIS DRAWING IS THE SOLE PROPERTY OF CROWN INDUSTRIAL. ANY REPRODUCTION IN PART OR AS A WHOLE WITHOUT THE WRITTEN PERMISSION OF CROWN INDUSTRIAL IS PROHIBITED.	ID #:	0000415	STOCK PART #:	416-1
	MATERIAL:			
DESCRIPTION: 416 Tite Tite Bolt w/ 416-14 Flush Keeper, Bypassing Application				
FINISH:	Clear Zinc	# PCS:	REV:	



CROWN INDUSTRIAL
So. San Francisco, Ca
(650) 952-5150
www.crown-industrial.com

DWG #: 416
DRAWN:BCM 2/19/2009
SHEET #3
File: 0000400.idw

4

3



2

1

4

3

2

1

D

D

C

C

B

B

A

A

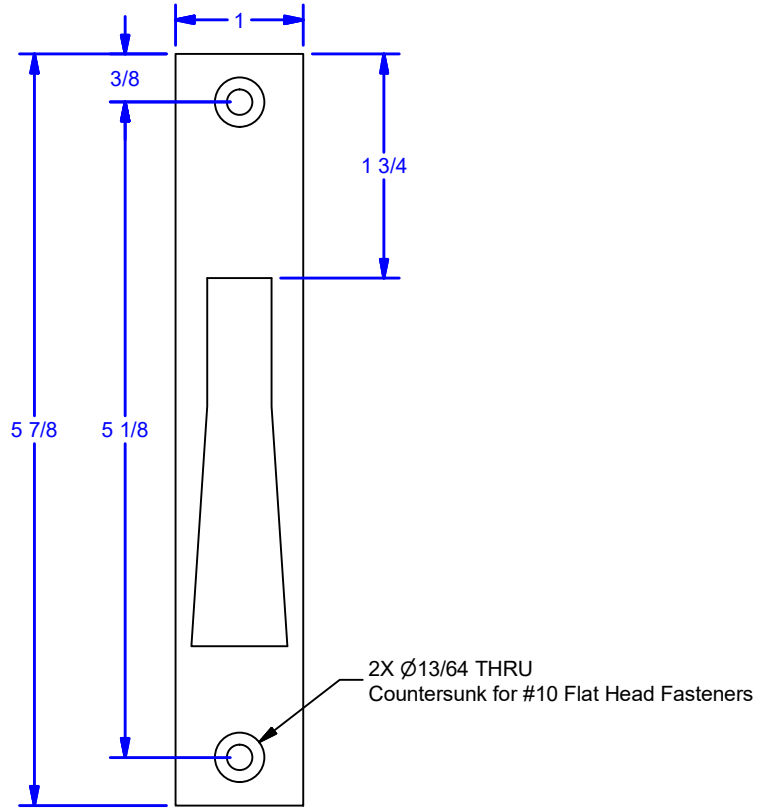
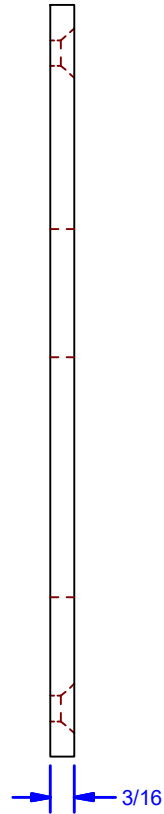

ALL DIMENSIONS IN INCHES

THE INFORMATION CONTAINED IN THIS DRAWING IS THE SOLE PROPERTY OF CROWN INDUSTRIAL. ANY REPRODUCTION IN PART OR AS A WHOLE WITHOUT THE WRITTEN PERMISSION OF CROWN INDUSTRIAL IS PROHIBITED.	ID #:	0000399	STOCK PART #:	416-14
	MATERIAL:	Stainless Steel		
DESCRIPTION: Flush Keeper, Bi-passing				
FINISH:	#4 Brushed	# PCS:	1	REV:



CROWN INDUSTRIAL

So. San Francisco, Ca
(650) 952-5150
www.crown-industrial.com

DWG #: 416
DRAWN:BCM 2/18/2009
SHEET #6
File: 0000400.idw

4

3

2

1

