

**DETAIL A**

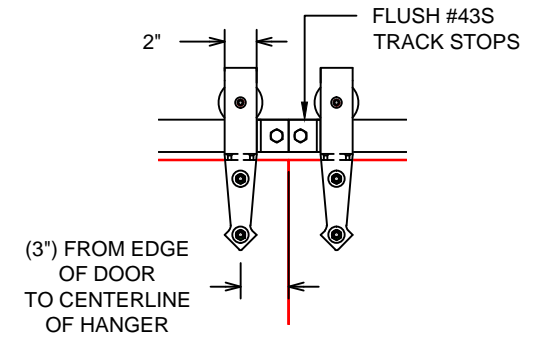

**DETAIL B**

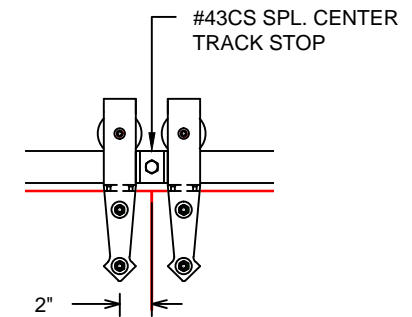

**DETAIL C**

**INDICATE:**

1. OPENING WIDTH:
2. DOOR WIDTH:
3. DOOR THICKNESS:
4. FROM THE EDGE OF THE DOOR TO THE CENTERLINE OF THE FLAT TRACK HANGER:
5. PROJECTION OF MATERIALS BEYOND WALL BLOCKING: (FOR WALL SPACER LENGTH- SEE SHEET 2)
6. FIELD OR FACTORY DRILL TRACK MOUNTING HOLES:

43 FLAT TRACK  
 DESCRIP: Flat Track Elevation - 43H-DEC Biparting (400LB CAPACITY)  
 DRAWN:BCM 10-23-09  
 SCALE: NONE  
 SHEET # 1

FILE:z:\engineering\hardware\43flat\flat track template\flat track customer template 10-23-09

THE INFORMATION CONTAINED IN THIS DRAWING IS THE SOLE PROPERTY OF CROWN INDUSTRIAL. ANY REPRODUCTION IN PART OR AS A WHOLE WITHOUT WRITTEN PERMISSION OF CROWN INDUSTRIAL IS PROHIBITED.



**CROWN  
 INDUSTRIAL**

So. San Francisco, Ca  
 (650) 952-5150

www.crown-industrial.com