

Assembled View

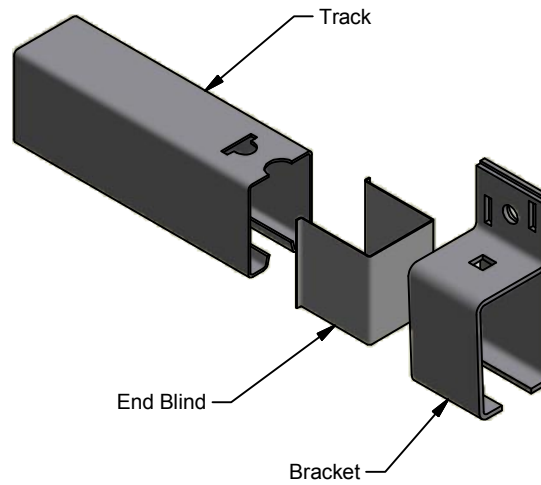

Disassembled View

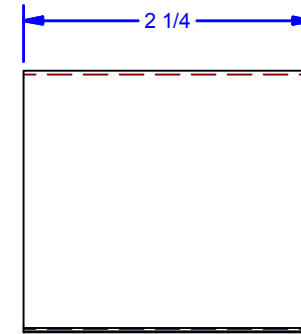
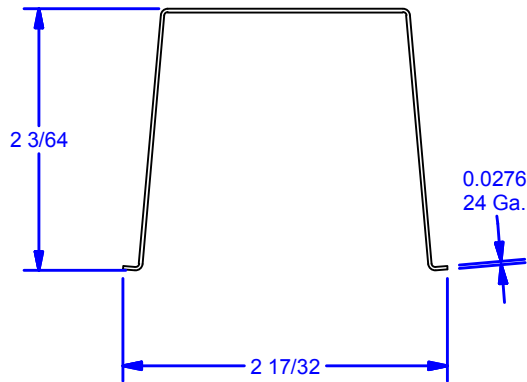
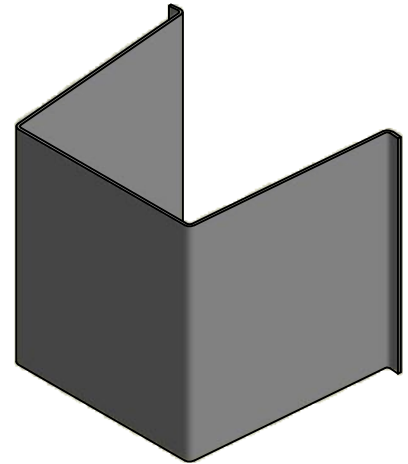

Purpose:
To Close off the ends of track as well as preventing creeping for one-piece track applications.

Press into track bracket, then push track into it.

- Available Finishes:**
- Powder Coat Black
 - Powder Coat Pebble Tan
 - Galvanized
 - 304 Stainless Steel - #2B Mill Finish
 - 304 Stainless Steel - #4 Brushed Finish

DWG #: 0002502
DRAWN:BCM 7/5/2013
SHEET #7
File: 0002502.idw

ALL DIMENSIONS IN INCHES 24 Ga.

THE INFORMATION CONTAINED IN THIS DRAWING IS THE SOLE PROPERTY OF CROWN INDUSTRIAL. ANY REPRODUCTION IN PART OR AS A WHOLE WITHOUT THE WRITTEN PERMISSION OF CROWN INDUSTRIAL IS PROHIBITED.	PART #:	STOCK #:
	0001511	4x2
DESCRIPTION:	MATERIAL:	
End Blind	Galvanized Steel	
FINISH:	# PCS:	REV:



CROWN INDUSTRIAL
So. San Francisco, Ca
(650) 952-5150
www.crown-industrial.com