

4 3 2 1

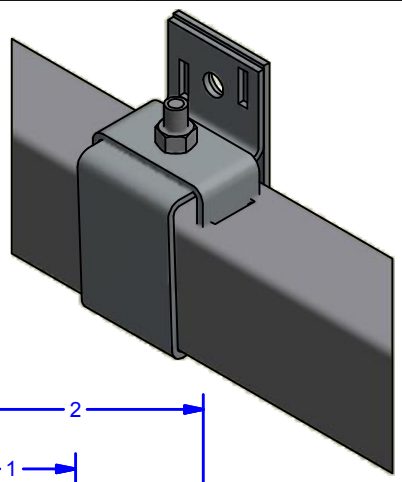

#3/8-16 UNC - 1
Short Neck Carriage Bolt w/ Nut

#0001784
#4 Joint Bracket Clip
*Used to join two tracks together.
Slide tracks into bracket,
drop bent ends of clip into holes
placed in the tops of each track.

#4x1
Center Bracket

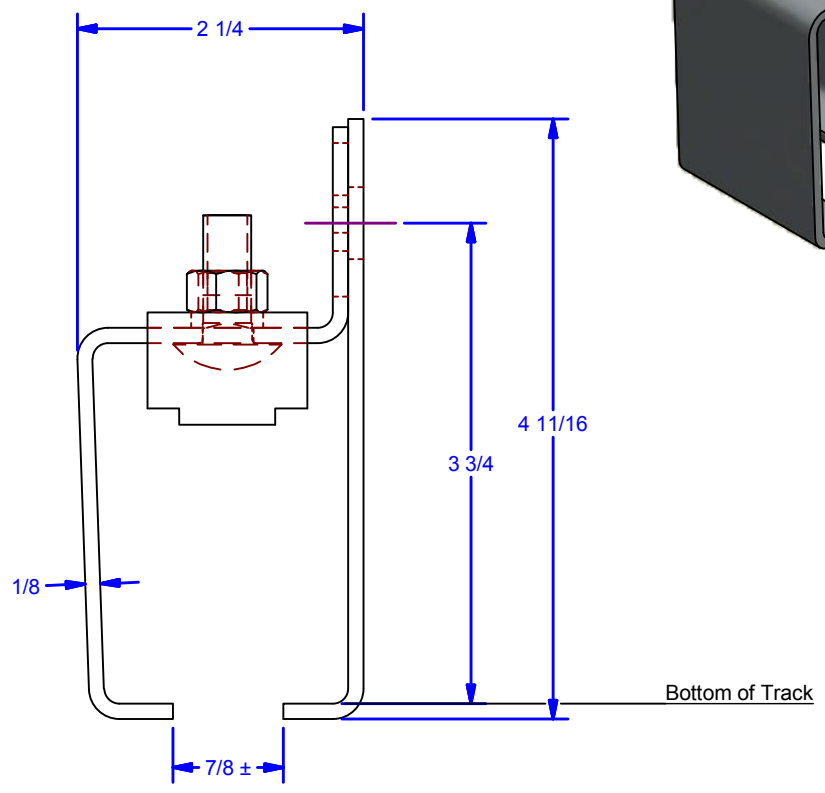
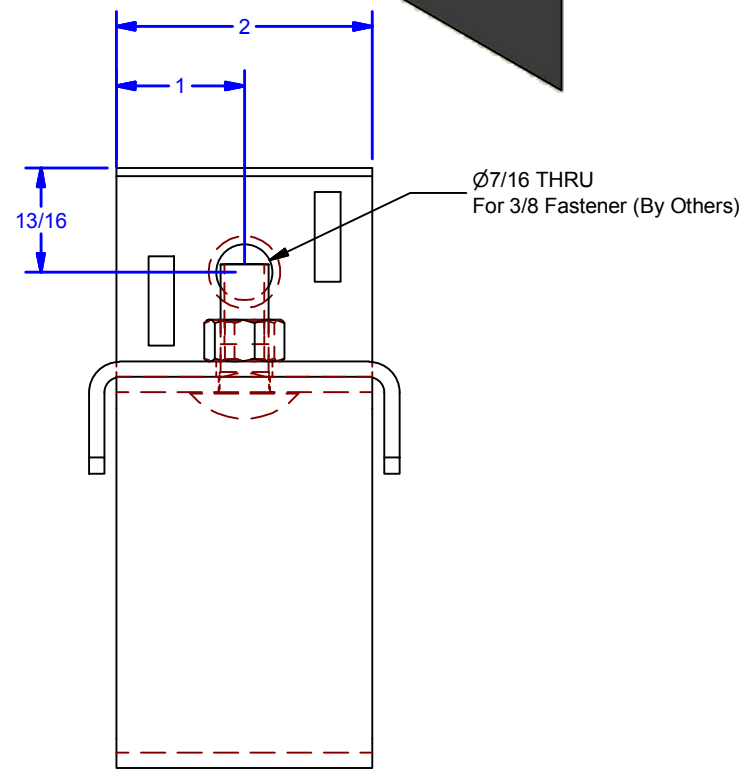
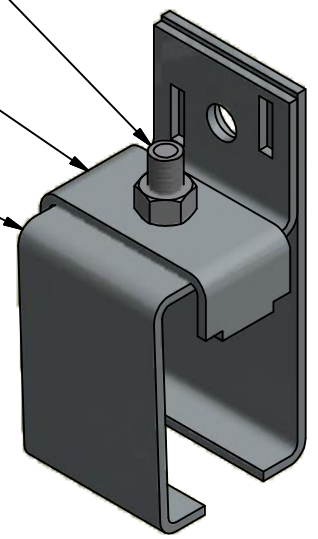

NOTE:
30" On Center Maximum Bracket Spacing.

Avail. Finishes:
Powder Coat Black
Powder Coat Pebble Tan
Galvanized
304 Stainless Steel - #2B Mill Finish
304 Stainless Steel - #4 Brushed Finish

ALL DIMENSIONS IN INCHES

THE INFORMATION CONTAINED IN THIS DRAWING IS THE SOLE PROPERTY OF CROWN INDUSTRIAL. ANY REPRODUCTION IN PART OR AS A WHOLE WITHOUT THE WRITTEN PERMISSION OF CROWN INDUSTRIAL IS PROHIBITED.	PART #:	STOCK #:
	0001785	4x39
DESCRIPTION:	MATERIAL:	
Sidewall Joint Bracket		
FINISH:	# PCS:	REV:
	1	



CROWN INDUSTRIAL
So. San Francisco, Ca
(650) 952-5150
www.crown-industrial.com

DWG #: 0002502
DRAWN:BCM 12/23/2014
SHEET #4
File: 0002502.idw

4 3 2 1