

Parts List			
ITEM	QTY	DESCRIPTION	STOCK #
2	1	Cane	
3	1	524p23 Cane Retainer	
4	2	524P23 Guide Clip	
5	6	Round Head Phillips Wood Screw, Zinc	14-10 x 1-1/4
6	1	524P43 Floor Insert Sleeve for 524P23	0524.00043
7	1	(2pc) Clamping Collar, 3/4" I.D. x 1-1/2" O.D., Zinc w/ S.S. FASTENERS	
8	1	Pad Lockable Assembly for 524 Cane Bolt	0524PL-Z
9	2	Pan Head Phillips Sheet Metal Screw	1/4-14 x 1 1/4
10	1	Padlock (By Others) Max. Shackle Dia: 1/2" Min. Vertical Clear: 1-3/4", Min. Horiz. Clear: 1"	
11	1	SAE Flat Washer-zinc	3/4" SAE-FW
12	1	524P23SPD/SPU Spring, S.S.	

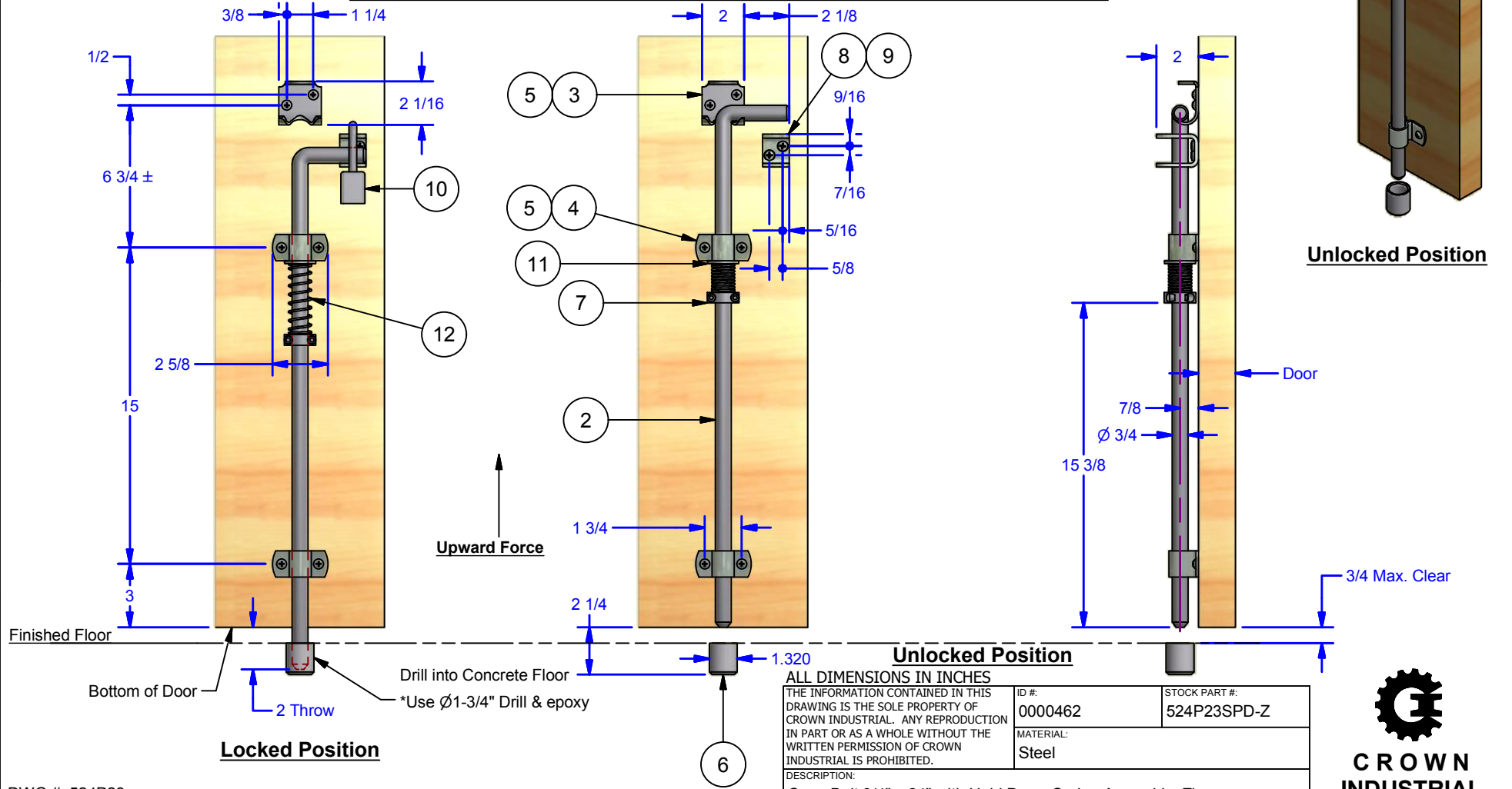

DWG #: 524P23
 DRAWN:BCM 7/31/2015
 SHEET #2
 File: 0000461.idw

*Alternative Finish: #0524.00023SPU-BZ black zinc

ALL DIMENSIONS IN INCHES		
THE INFORMATION CONTAINED IN THIS DRAWING IS THE SOLE PROPERTY OF CROWN INDUSTRIAL. ANY REPRODUCTION IN PART OR AS A WHOLE WITHOUT THE WRITTEN PERMISSION OF CROWN INDUSTRIAL IS PROHIBITED.	ID #: 0000462	STOCK PART #: 524P23SPD-Z
DESCRIPTION: Cane Bolt 3/4" x 24" with Hold Down Spring Assembly, Zinc	MATERIAL: Steel	
FINISH: US2C Zinc	# PCS: 1	REV: A

CROWN INDUSTRIAL
 So. San Francisco, Ca
 (650) 952-5150
 www.crown-industrial.com

4

3

2

1

Parts List

ITEM	QTY	PART #	DESCRIPTION	STOCK #
1	1	0001952x3.4	524P23SPD/SPU Spring, S.S.	
2	1	0001019	(2 PC) Clamping Collar	
3	1	SAE FW 3/4 - narrow - Type A	SAE Flat Washer	
4	1	0000049	Pad Lockable Assembly for 524 Cane Bolt	0524PL-Z
5	2	PHPSMS 1/4-14 - 1 1/4	Pan Head Phillips Sheet Metal Screw	1/4-14 x 1 1/4

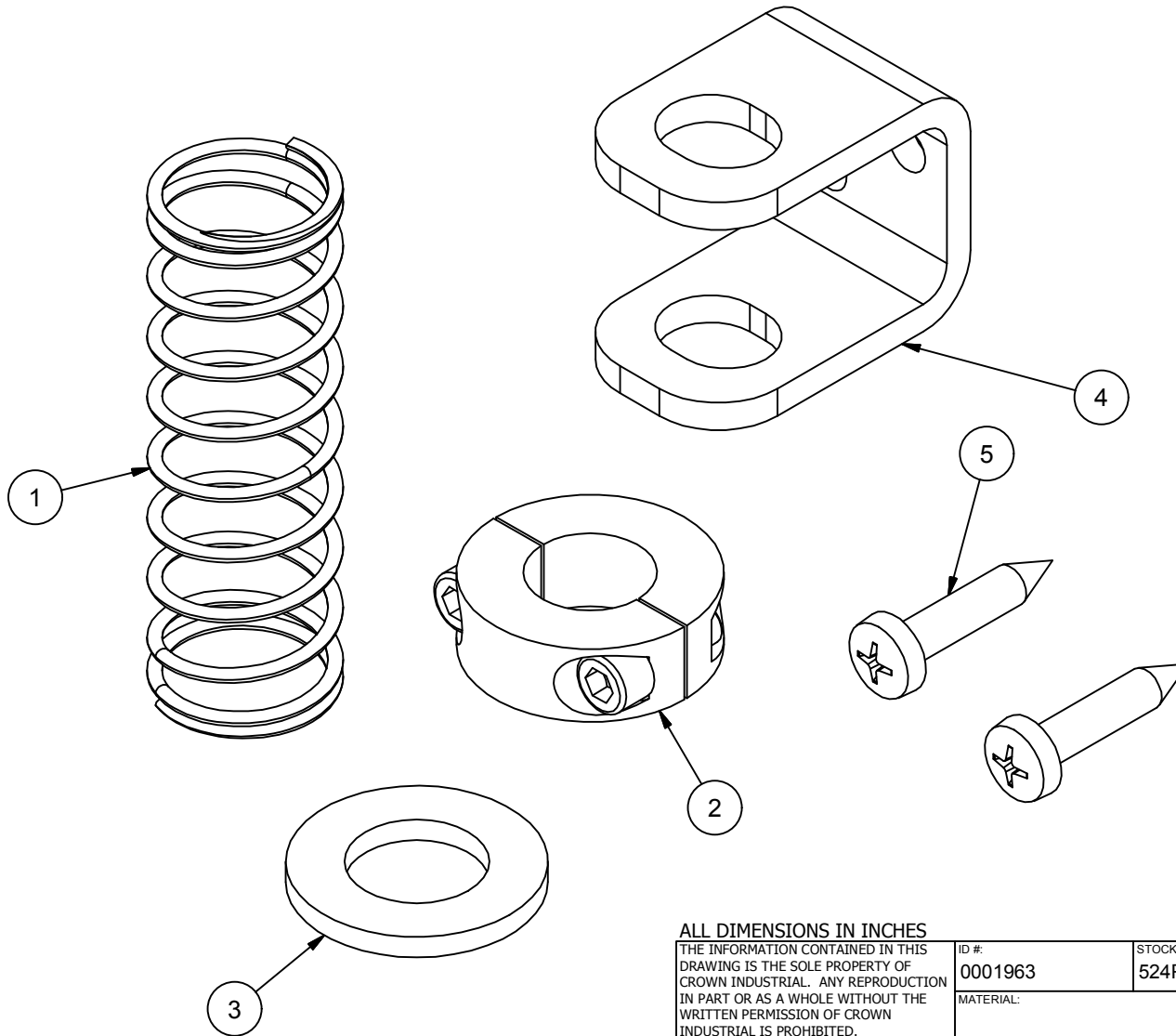

ALL DIMENSIONS IN INCHES

THE INFORMATION CONTAINED IN THIS DRAWING IS THE SOLE PROPERTY OF CROWN INDUSTRIAL. ANY REPRODUCTION IN PART OR AS A WHOLE WITHOUT THE WRITTEN PERMISSION OF CROWN INDUSTRIAL IS PROHIBITED.	ID #:	0001963	STOCK PART #:	524P23SP
	MATERIAL:			
DESCRIPTION: 524 P23 HoldUp/Down Spring Kit				
FINISH:			# PCS:	REV:
			1	



CROWN INDUSTRIAL

So. San Francisco, Ca
(650) 952-5150

www.crown-industrial.com

DWG #: 524P23
DRAWN:BCM 4/13/2015
SHEET #7

File: 0000461.idw

4

3

2

1

D

D

C

C

B

B

A

A

Parts List				
ITEM	QTY	PART #	DESCRIPTION	STOCK #
1	1	0001016	524P23 Cane, S.S.	
2	1	0001013	Cane Retainer, S.S.	
3	2	0001951	524P23 Guide Clip Weldment, S.S.	
4	8	PHPSMS 1/4-14 - 1 1/4	Pan Head Phillips Sheet Metal Screw	1/4-14 x 1 1/4
5	1	0001961	Keeper for 0524.00023 Cane Bolt-SS #2B	0524.00043-S
6	1	0001017	Pad Lockable Assembly for 524 S.S. Cane Bolt	0524PL-S
7	1	0001019	(2pc) Clamping Collar	
8	1	0000482	Padlock (By Others), Max. Shackle Dia: 1/2" Min. Vertical Clear: 1-3/4", Min. Horiz. Clear: 1"	
9	1	SAE FW 3/4 - narrow - Type A S.S. 18-8	SAE Flat Washer-S.S. 18-8	3/4" SAE-FW-S
10	1	0001952x3.359	524P23SPD/SPU Spring, S.S.	

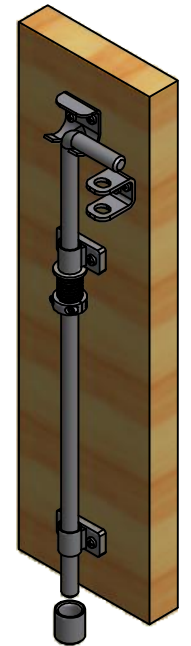

Unlocked Position

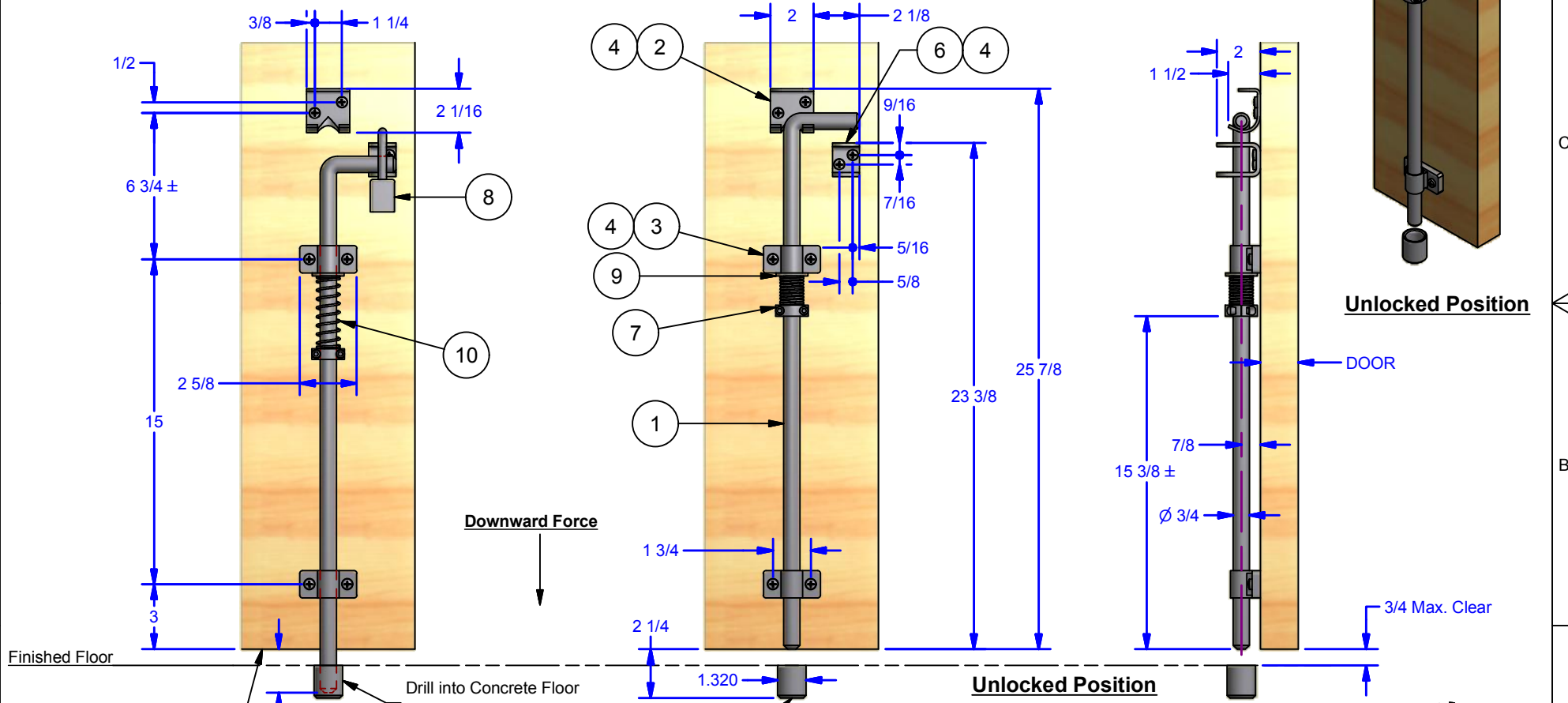

ALL DIMENSIONS IN INCHES			
THE INFORMATION CONTAINED IN THIS DRAWING IS THE SOLE PROPERTY OF CROWN INDUSTRIAL. ANY REPRODUCTION IN PART OR AS A WHOLE WITHOUT THE WRITTEN PERMISSION OF CROWN INDUSTRIAL IS PROHIBITED.		ID #: 0001962	STOCK PART #: 524P23SPD-S
DESCRIPTION: Cane Bolt 3/4" x 24" with Hold Down Spring Assembly, Stainless Steel		MATERIAL: 304 Stainless Steel	
FINISH: Brushed		# PCS: 1	REV: A

CROWN INDUSTRIAL
So. San Francisco, Ca
(650) 952-5150
www.crown-industrial.com

DWG #: 524P23
DRAWN:BCM 7/31/2015
SHEET #6
File: 0000461.idw