

4

3

2

1

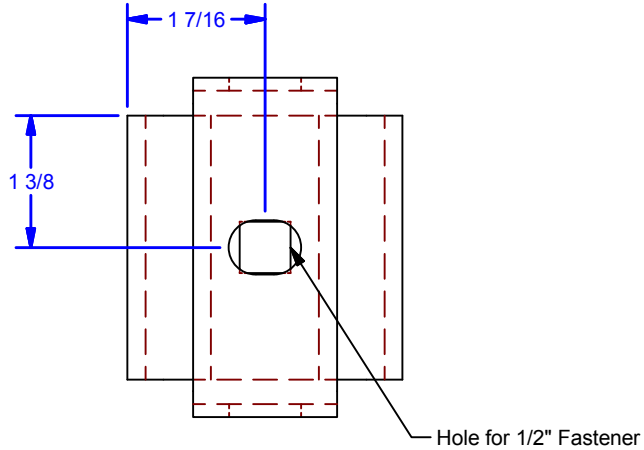

#0001396  
#6 Joint Bracket Clip  
\*Used to join two tracks together.  
Slide tracks into bracket,  
drop bent ends of clip into holes  
that exist in the tops of each track.

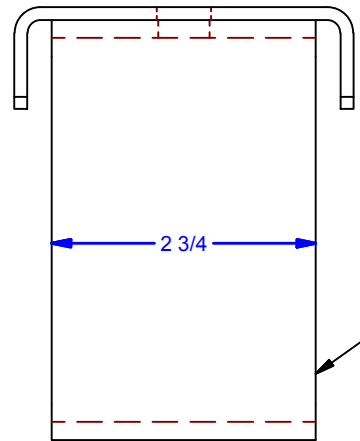
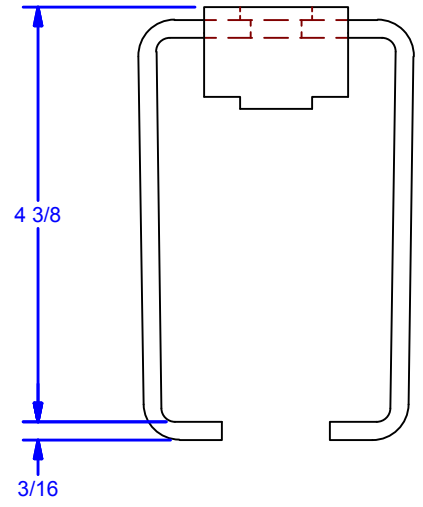
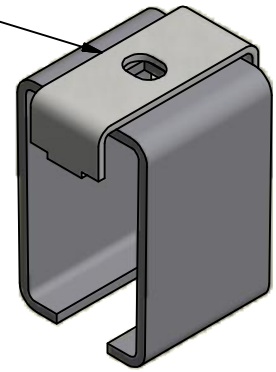

#0001818  
Overhead Joint Bracket

**Note:**  
24" On Center Maximum Bracket Spacing

**Avail. Finishes:**  
Powder Coat Black  
Powder Coat Pebble Tan  
Galvanized  
304 Stainless Steel - #2B Mill Finish  
304 Stainless Steel - #4 Brushed Finish

DWG #: 0002250  
DRAWN:BCM 2/2/2015  
SHEET #5  
File: 0002250.idw

**ALL DIMENSIONS IN INCHES**

THE INFORMATION CONTAINED IN THIS DRAWING IS THE SOLE PROPERTY OF CROWN INDUSTRIAL. ANY REPRODUCTION IN PART OR AS A WHOLE WITHOUT THE WRITTEN PERMISSION OF CROWN INDUSTRIAL IS PROHIBITED.	ID #:	0001819	STOCK PART #:	6x189
	MATERIAL:			
DESCRIPTION: Overhead Joint Bracket				
FINISH:			# PCS:	REV:
			1	



**CROWN INDUSTRIAL**  
So. San Francisco, Ca  
(650) 952-5150  
www.crown-industrial.com

4

3

2

1

D

D

C

C

B

B

A

A