

#0001396
#6 Joint Bracket Clip
*Used to join two tracks together.
Slide Tracks into bracket,
drop bent ends of clip into holes
that exist in the tops of each track

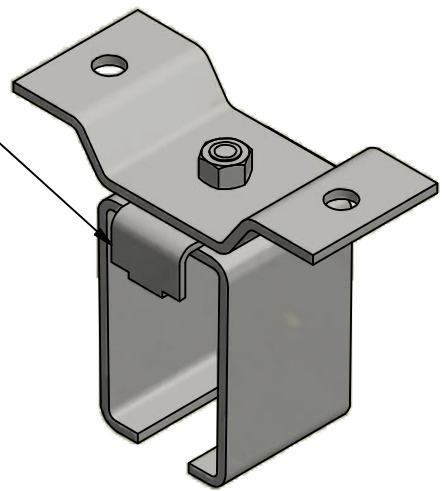

2X Ø9/16 THRU
For 1/2 Hex Head Bolt

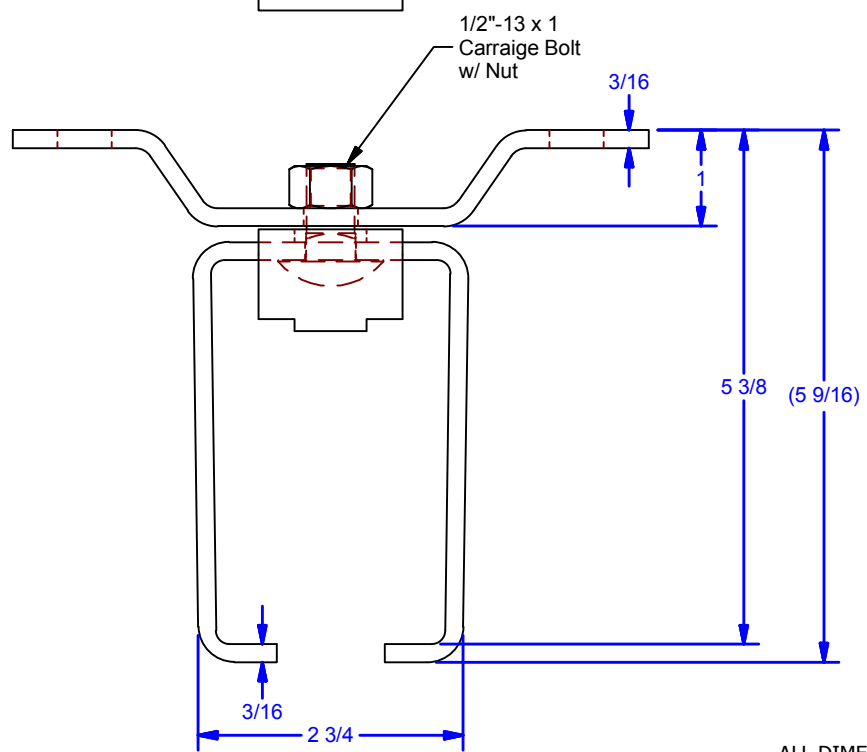

Note:
24" On Center Maximum Bracket Spacing

Avail. Finishes:
6Px59B: Powder Coat Black
6Px59: Powder Coat Pebble Tan
6Gx59: Galvanized
6Sx59: 304 Stainless Steel - #2B Mill Finish
6Sx59-S: 304 Stainless Steel - #4 Brushed Finish

ALL DIMENSIONS IN INCHES

THE INFORMATION CONTAINED IN THIS DRAWING IS THE SOLE PROPERTY OF CROWN INDUSTRIAL. ANY REPRODUCTION IN PART OR AS A WHOLE WITHOUT THE WRITTEN PERMISSION OF CROWN INDUSTRIAL IS PROHIBITED.	ID #:	0001826	STOCK PART #:	6x59
	MATERIAL:			
DESCRIPTION: Cross Ear Center Joint Bracket				
FINISH:			# PCS:	REV:



CROWN INDUSTRIAL
So. San Francisco, Ca
(650) 952-5150
www.crown-industrial.com

DWG #: 0002250
DRAWN:BCM 2/3/2015
SHEET #7
File: 0002250.idw