

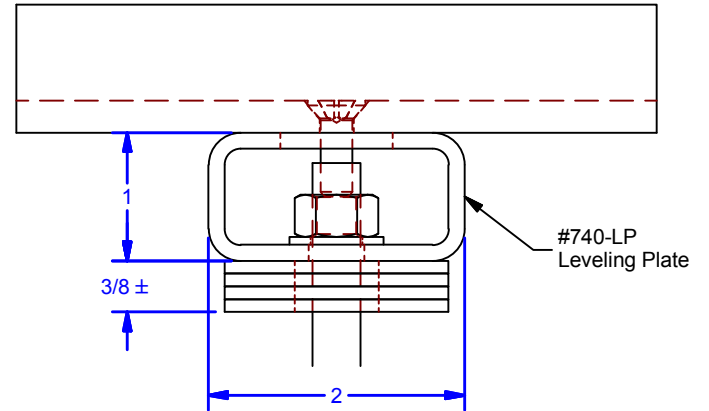

(FHPMS) 1/4-20 x 3/4 Zinc Flat Head Phillips Head Machine Screw
 *Field Drill, Countersink & Tap, By Others

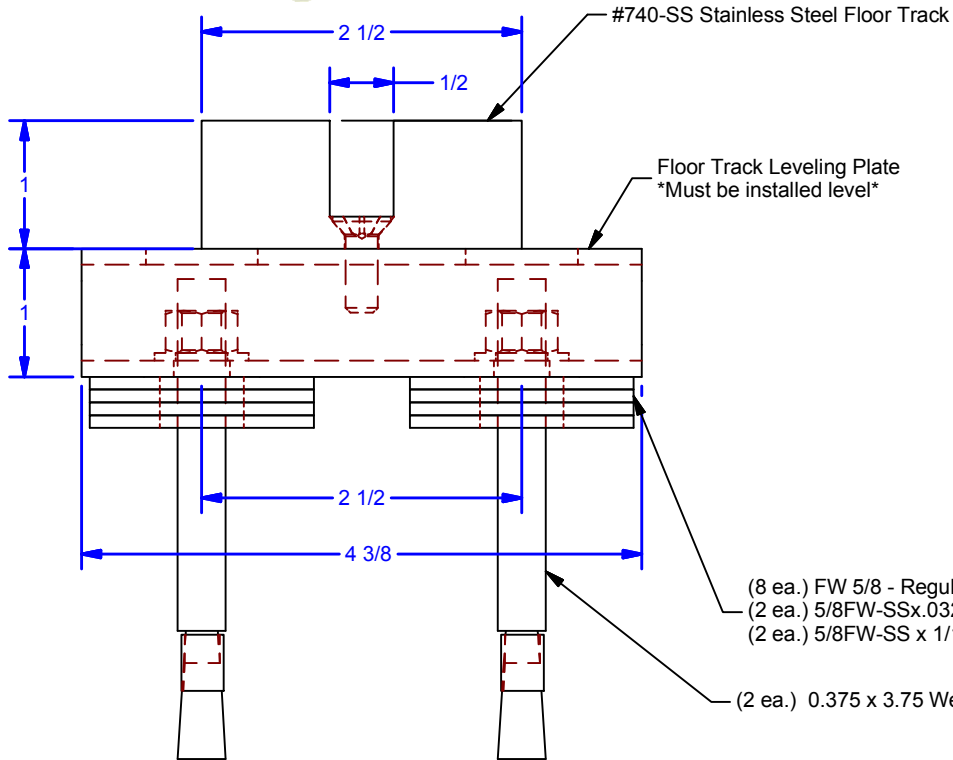
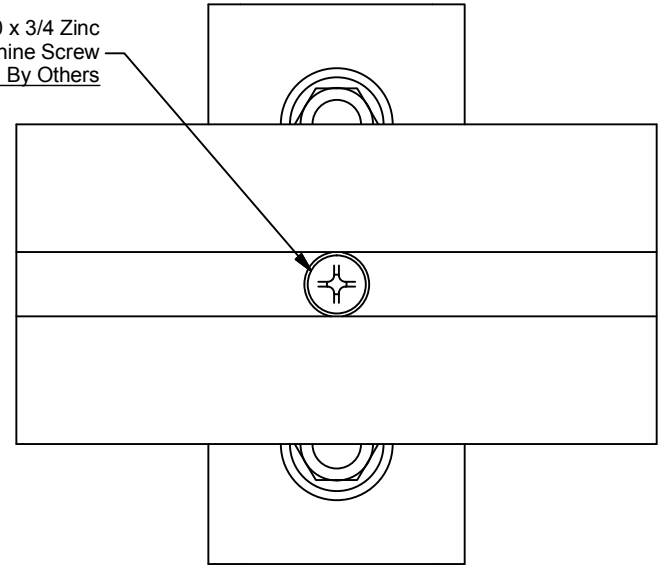

Sectional End View

ALL DIMENSIONS IN INCHES

THE INFORMATION CONTAINED IN THIS DRAWING IS THE SOLE PROPERTY OF CROWN INDUSTRIAL. ANY REPRODUCTION IN PART OR AS A WHOLE WITHOUT THE WRITTEN PERMISSION OF CROWN INDUSTRIAL IS PROHIBITED.

ID #: 0002217

STOCK PART #: 740-L

MATERIAL:

DESCRIPTION:

Leveling Plate Assembly @ 24" Centers

FINISH:

Prime Ptd.

PCS: 1

REV:

DWG #: 0000484
 DRAWN:BCM 2/5/2016
 SHEET #3
 File: 0000484.idw

CROWN INDUSTRIAL
 So. San Francisco, Ca
 (650) 952-5150
 www.crown-industrial.com