

4

3

2

1

D

D

C

C

B

B

A

A

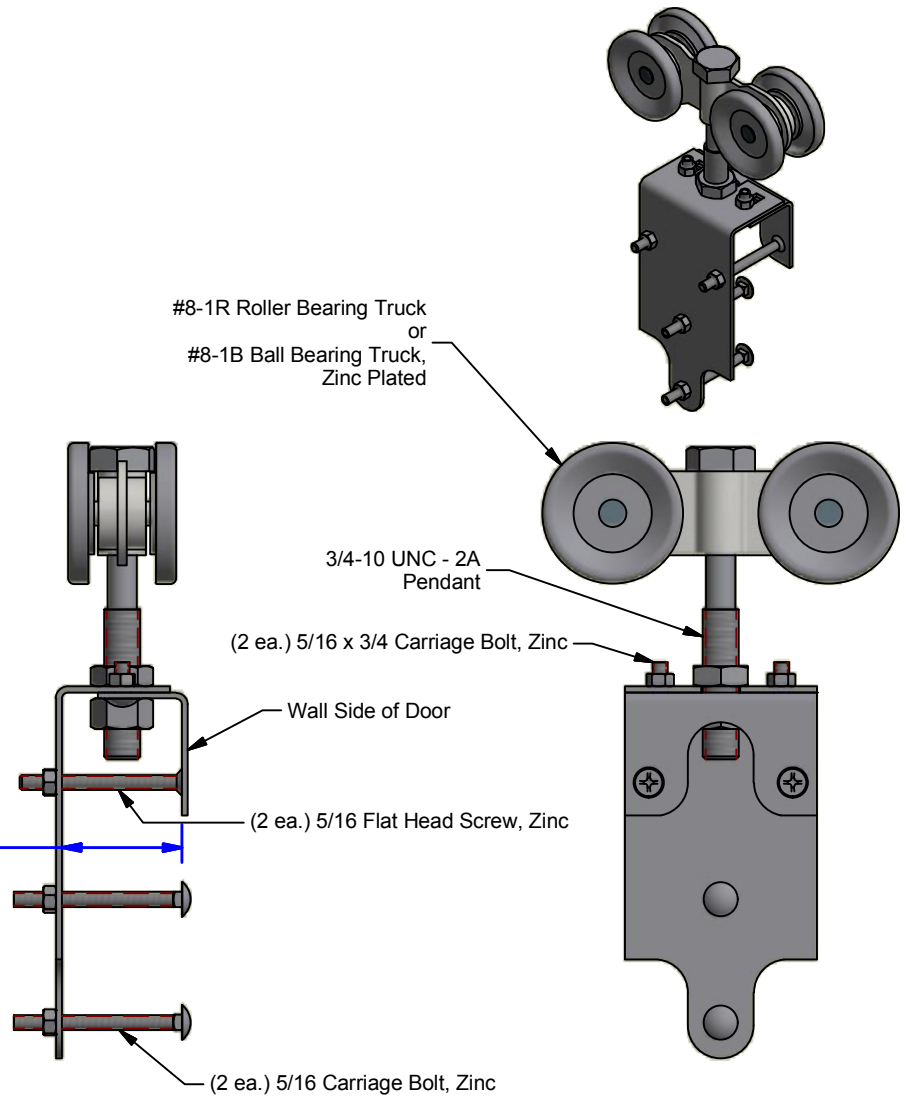
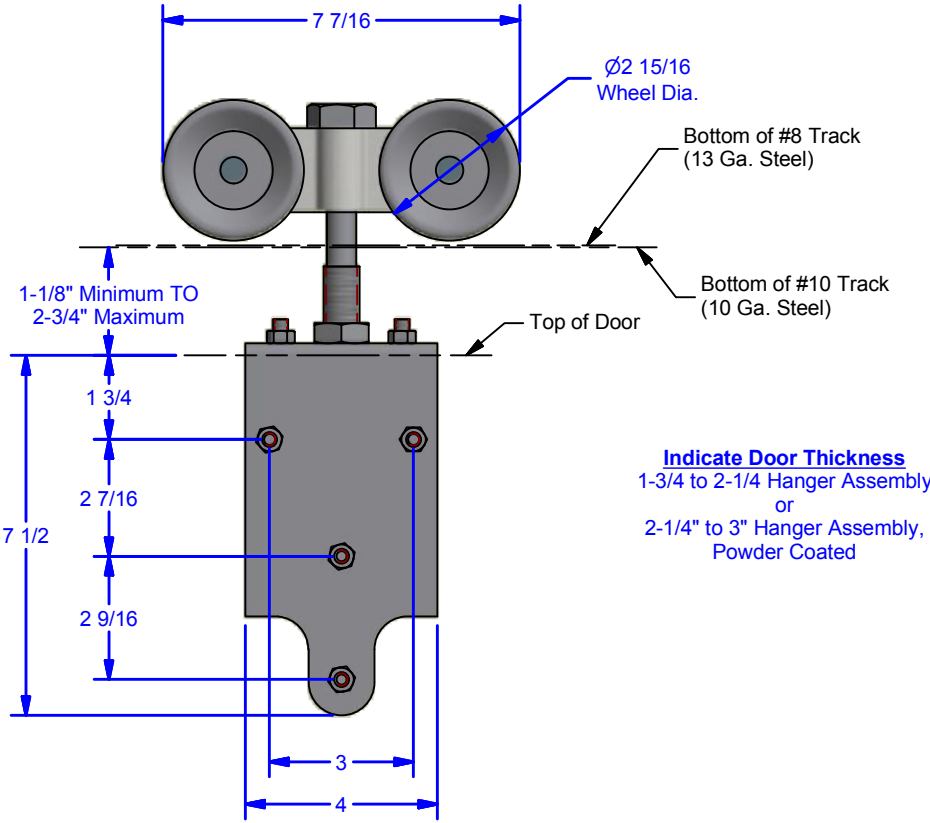

Hardware Sold In Pairs

ALL DIMENSIONS IN INCHES

|  |           |         |               |      |
|--|-----------|---------|---------------|------|
| THE INFORMATION CONTAINED IN THIS DRAWING IS THE SOLE PROPERTY OF CROWN INDUSTRIAL. ANY REPRODUCTION IN PART OR AS A WHOLE WITHOUT THE WRITTEN PERMISSION OF CROWN INDUSTRIAL IS PROHIBITED. | ID #:     | 0002435 | STOCK PART #: | 8H   |
|  | MATERIAL: |         |               |      |
| DESCRIPTION:<br>Hanger   |           |         |               |      |
| FINISH:  |           |         | # PCS:        | REV: |
|  |           |         | 1             |      |



**CROWN INDUSTRIAL**  
So. San Francisco, Ca  
(650) 952-5150  
www.crown-industrial.com

DWG #: 0001976  
DRAWN: BCM 3/1/2017  
SHEET #2  
File: 0001976.idw

4

3

2

1

