

4

3

2

1

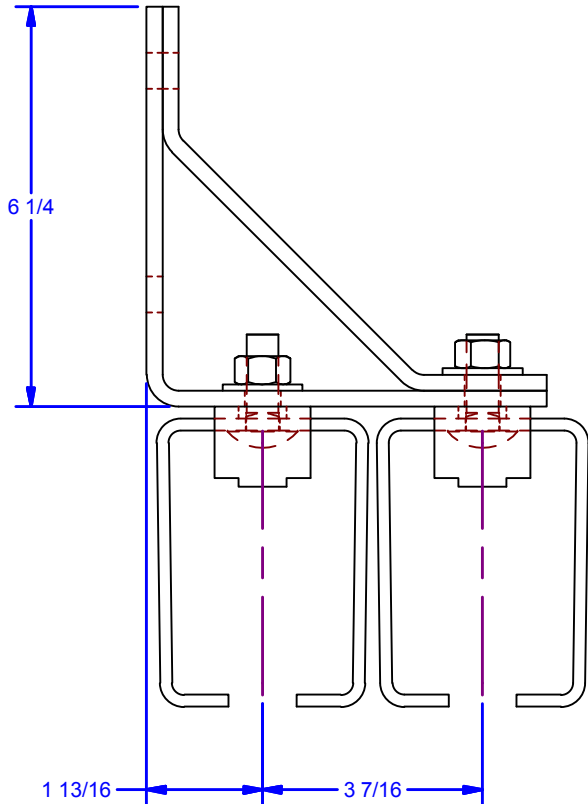
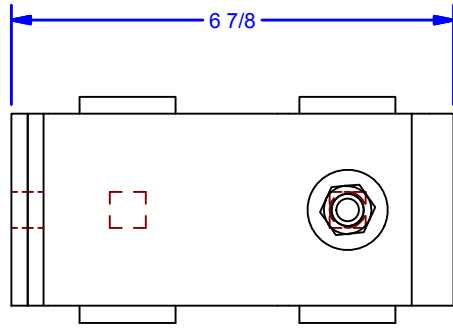

2X Ø9/16 SQ. THRU
For 1/2 Fastener

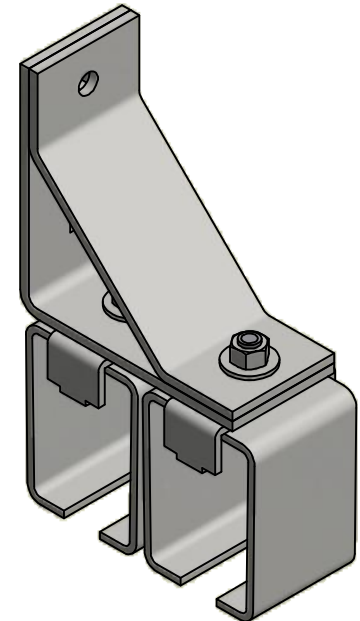
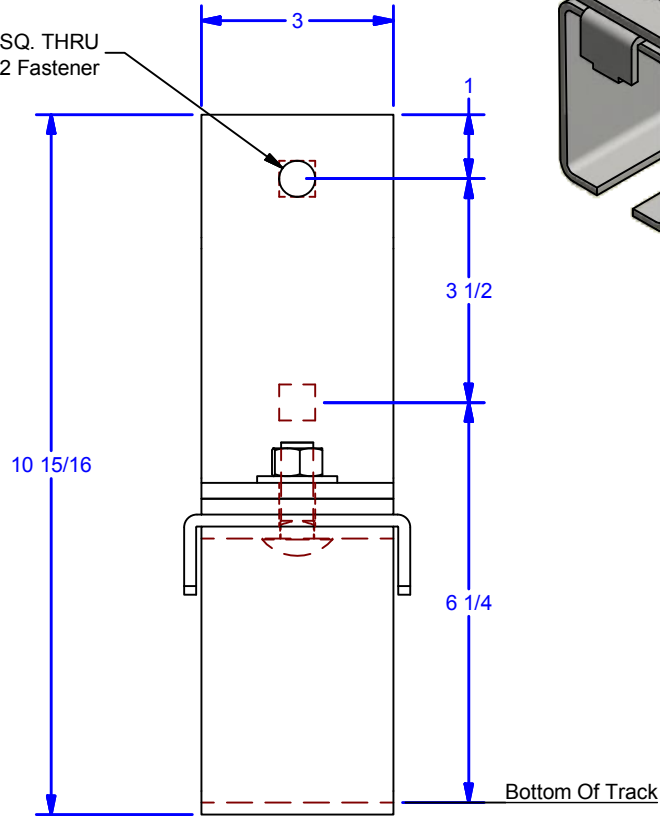

Note:
24" On Center Maximum Bracket Spacing

Avail. Finishes:
8Px229B: Powder Coat Black
8Px229: Powder Coat Pebble Tan

DWG #: 0001838
DRAWN:BCM 2/6/2015
SHEET #7
File: 0001838.idw

ALL DIMENSIONS IN INCHES

THE INFORMATION CONTAINED IN THIS DRAWING IS THE SOLE PROPERTY OF CROWN INDUSTRIAL. ANY REPRODUCTION IN PART OR AS A WHOLE WITHOUT THE WRITTEN PERMISSION OF CROWN INDUSTRIAL IS PROHIBITED.	ID #:	0001848	STOCK PART #:	8x229
	MATERIAL:			
DESCRIPTION: Double Joint Bracket				
FINISH:		# PCS:	REV:	



CROWN INDUSTRIAL
So. San Francisco, Ca
(650) 952-5150
www.crown-industrial.com

4

3

2

1

D

D

C

C

B

B

A

A