

4

3

2

1

D

D

C

C

B

B

A

A

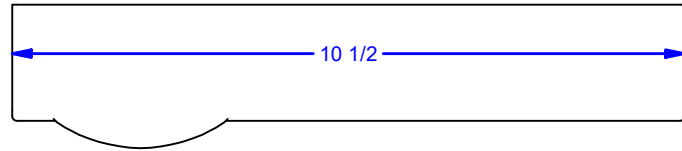

**Top View**

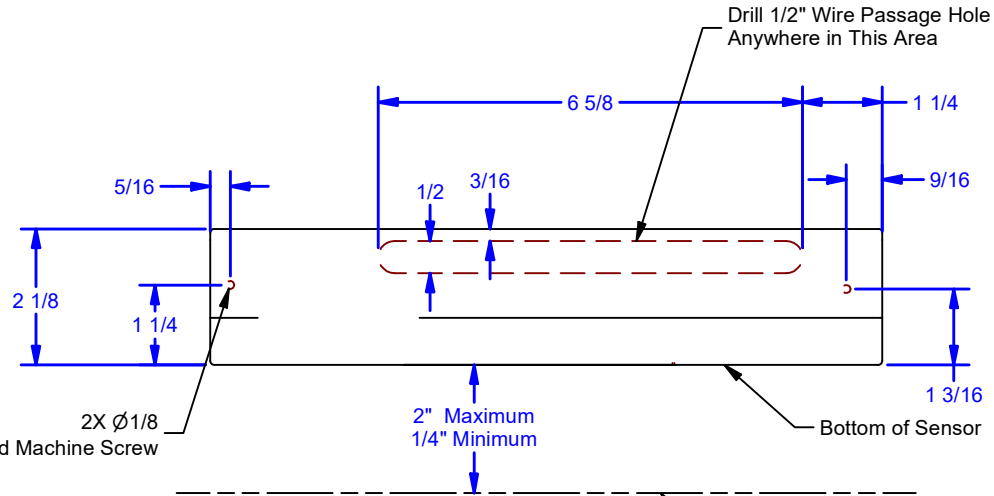
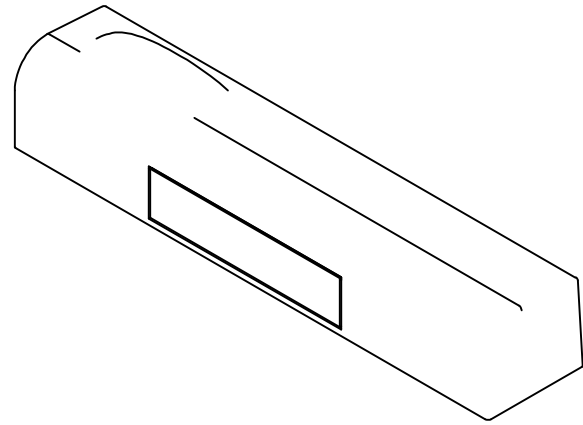

**Front Elevation**

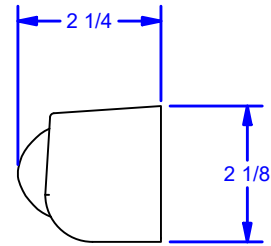

**Side View**

**For Reference Only,**

- Product supplied with
- Mounting Template
- (2 ea) #8x1/2 Pan Head Phillips Self Drilling Screws
- 29' Long Cable w. Harness

**Tech. Specs:**  
 Mounting Height: 6'-6" to 11'-6"  
 Temp. Range: -13 to 131 Degree F  
 IP54  
 Supply Voltage: 12-24 VAC +-10%  
 12-30 VDC +-10%  
 Power Consumption: < 2.5W

DWG #: 0002279  
 DRAWN:BCM 8/18/2020  
 SHEET #4  
 File: 0002279.idw

**ALL DIMENSIONS IN INCHES**

THE INFORMATION CONTAINED IN THIS DRAWING IS THE SOLE PROPERTY OF CROWN INDUSTRIAL. ANY REPRODUCTION IN PART OR AS A WHOLE WITHOUT THE WRITTEN PERMISSION OF CROWN INDUSTRIAL IS PROHIBITED.	ID #:	90000181	STOCK PART #:	IXIO-ST
	MATERIAL:		Plastic	
DESCRIPTION:				
Motion & Presense Sensor				
FINISH:			# PCS:	REV:
Black Plastic				



**CROWN INDUSTRIAL**  
 So. San Francisco, Ca  
 (650) 952-5150  
 www.crown-industrial.com

4

3

2

1