

4

3

2

1

D

D

C

C

B

B

A

A

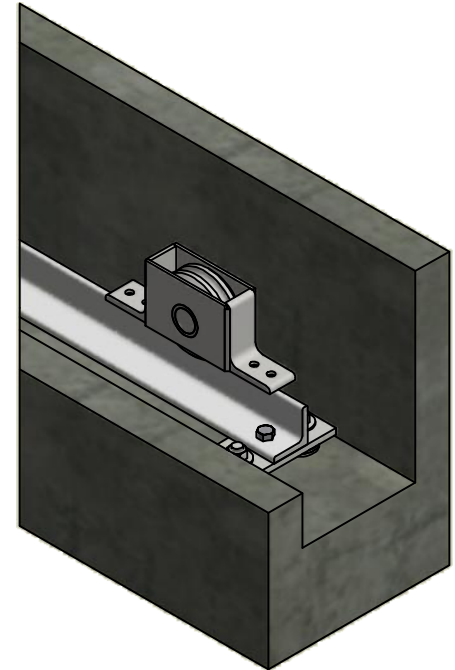
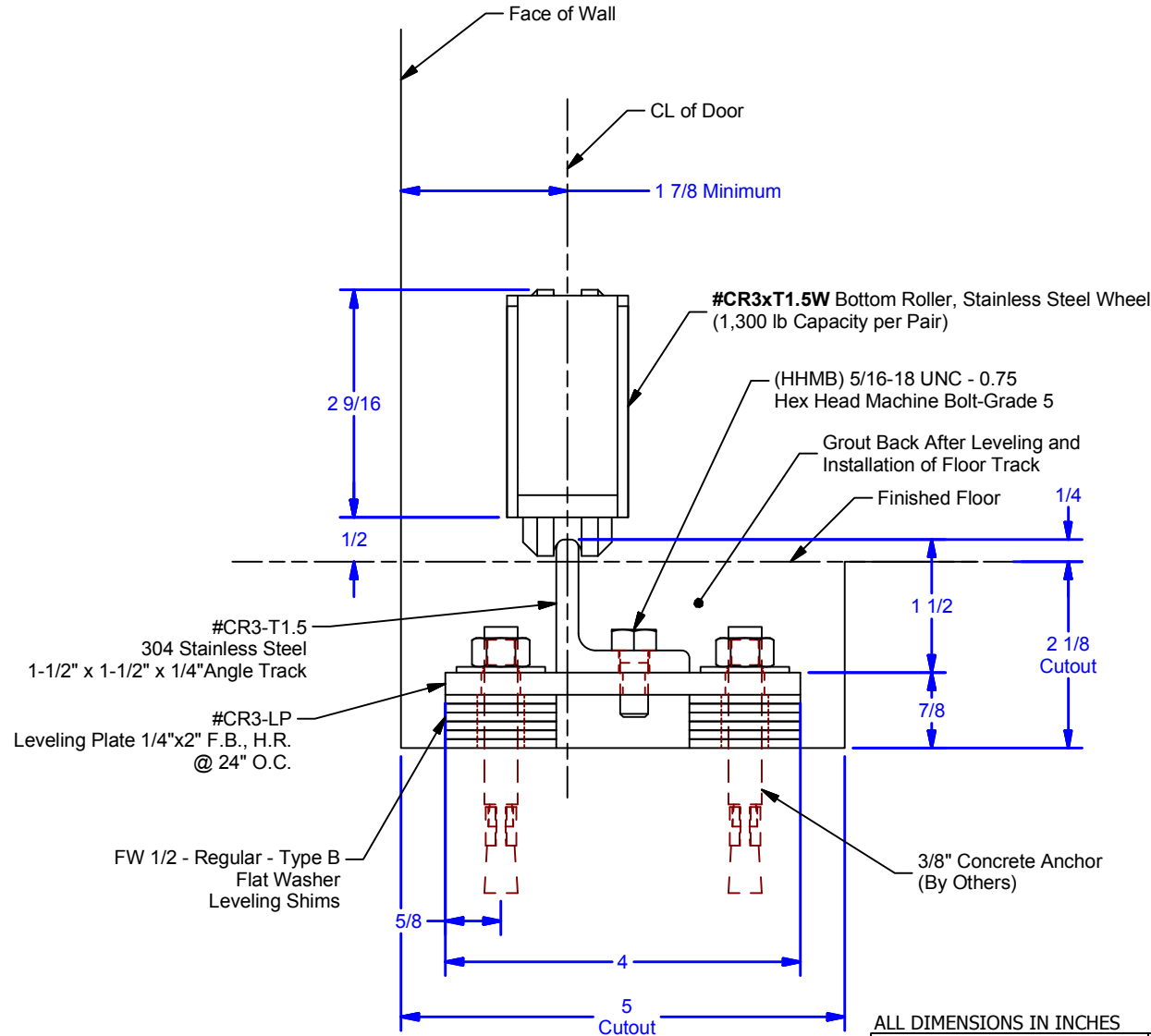

ALL DIMENSION $\pm 1/32"$
DO NOT USE AS TEMPLATE, REFERENCE ONLY DRAWING

ALL DIMENSIONS IN INCHES

THE INFORMATION CONTAINED IN THIS DRAWING IS THE SOLE PROPERTY OF CROWN INDUSTRIAL. ANY REPRODUCTION IN PART OR AS A WHOLE WITHOUT THE WRITTEN PERMISSION OF CROWN INDUSTRIAL IS PROHIBITED.

ID #:	0001686	STOCK PART #:	CR3xT1.5W
MATERIAL:			

DESCRIPTION:
Bottom Roller & Floor Track : Leveling Plate Option

FINISH:	# PCS:	REV:



CROWN INDUSTRIAL
 So. San Francisco, Ca
 (650) 952-5150
www.crown-industrial.com

DWG #: 0001676
 DRAWN:BCM 6/26/2014
 SHEET #3
 File: 0001676.idw

4

3

2

1



4

3

2

1

D

D

C

C

B

B

A

A

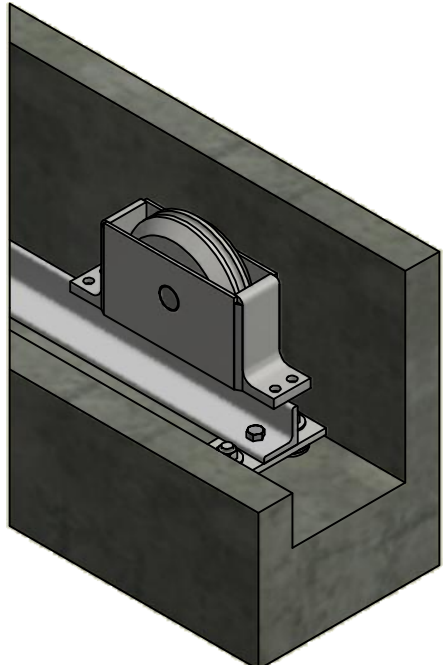
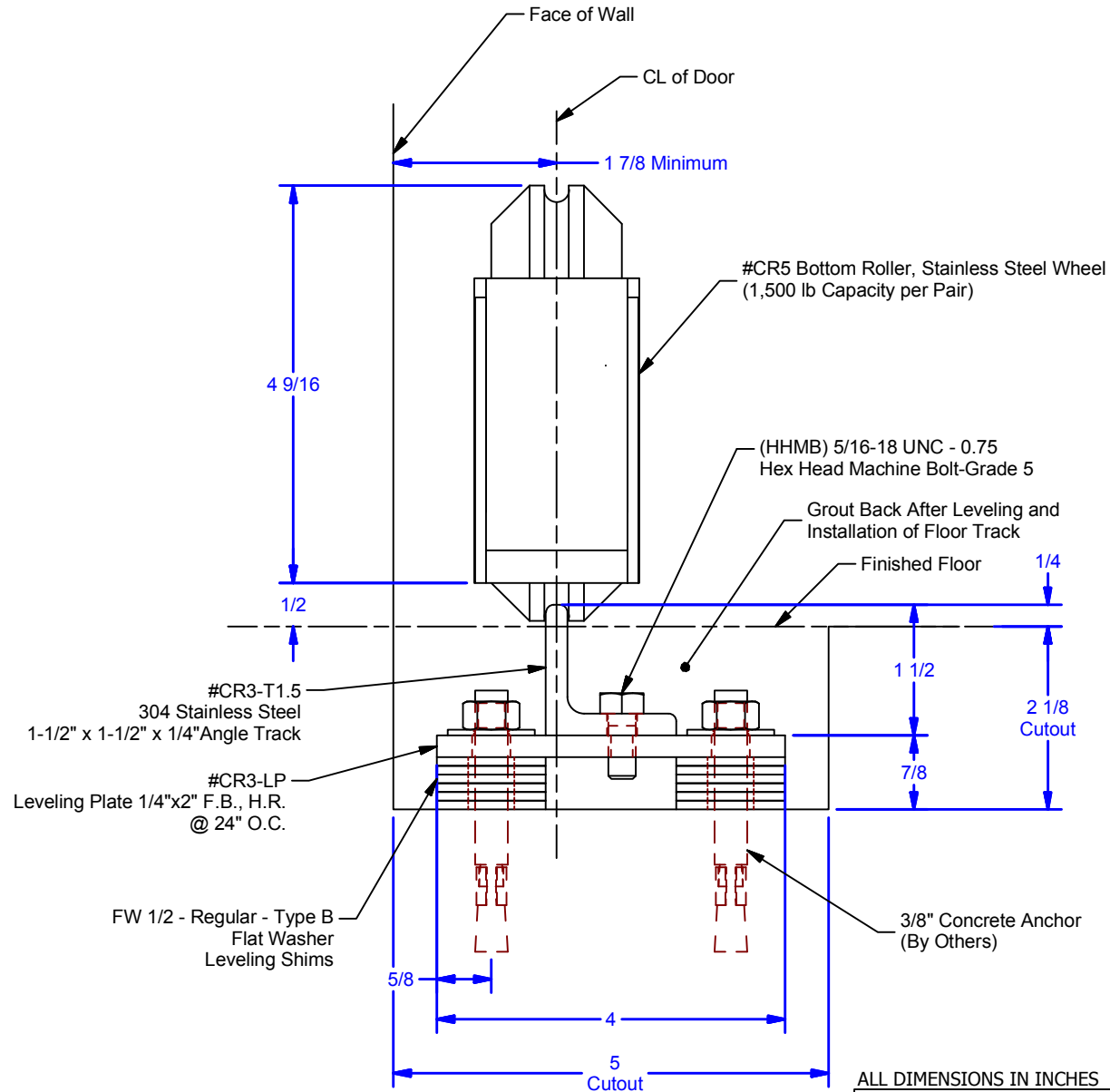

ALL DIMENSION ± 1/32"
***DO NOT USE AS TEMPLATE, REFERENCE ONLY DRAWING**

ALL DIMENSIONS IN INCHES

THE INFORMATION CONTAINED IN THIS DRAWING IS THE SOLE PROPERTY OF CROWN INDUSTRIAL. ANY REPRODUCTION IN PART OR AS A WHOLE WITHOUT THE WRITTEN PERMISSION OF CROWN INDUSTRIAL IS PROHIBITED.	ID #: 0001686	STOCK PART #:
DESCRIPTION: Bottom Roller & Floor Track : Leveling Plate Option	MATERIAL:	
FINISH:	# PCS:	REV:



CROWN INDUSTRIAL
 So. San Francisco, Ca
 (650) 952-5150
 www.crown-industrial.com

DWG #: 0002644
 DRAWN:BCM 6/26/2014
 SHEET #2
 File: 0002644.idw

4

3

2

1

