

4

3

2

1

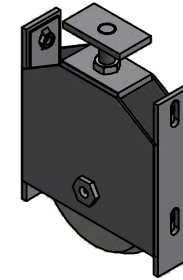
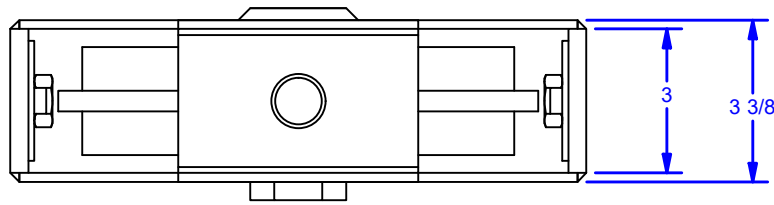

SECTION A-A

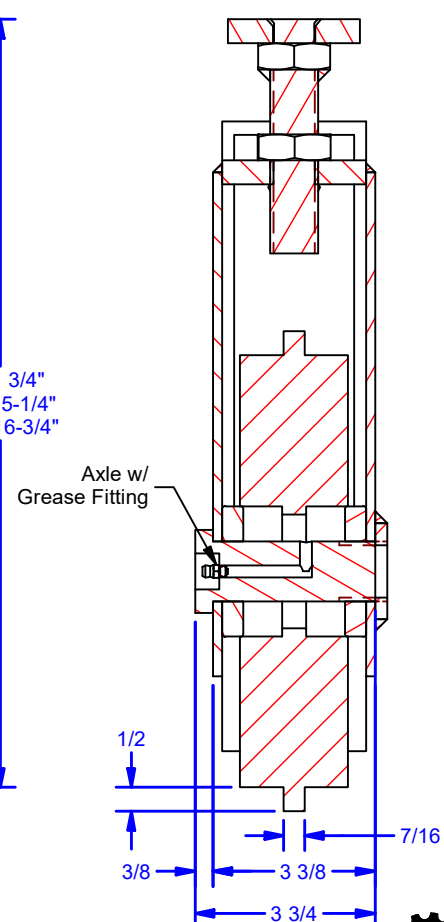
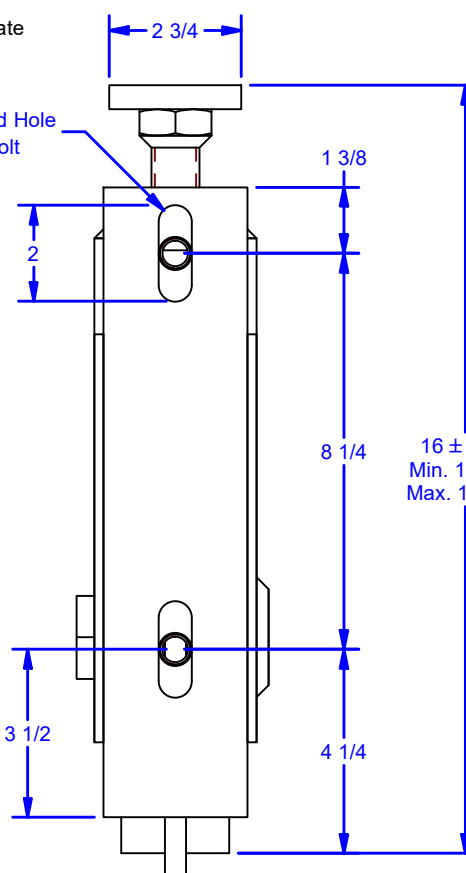
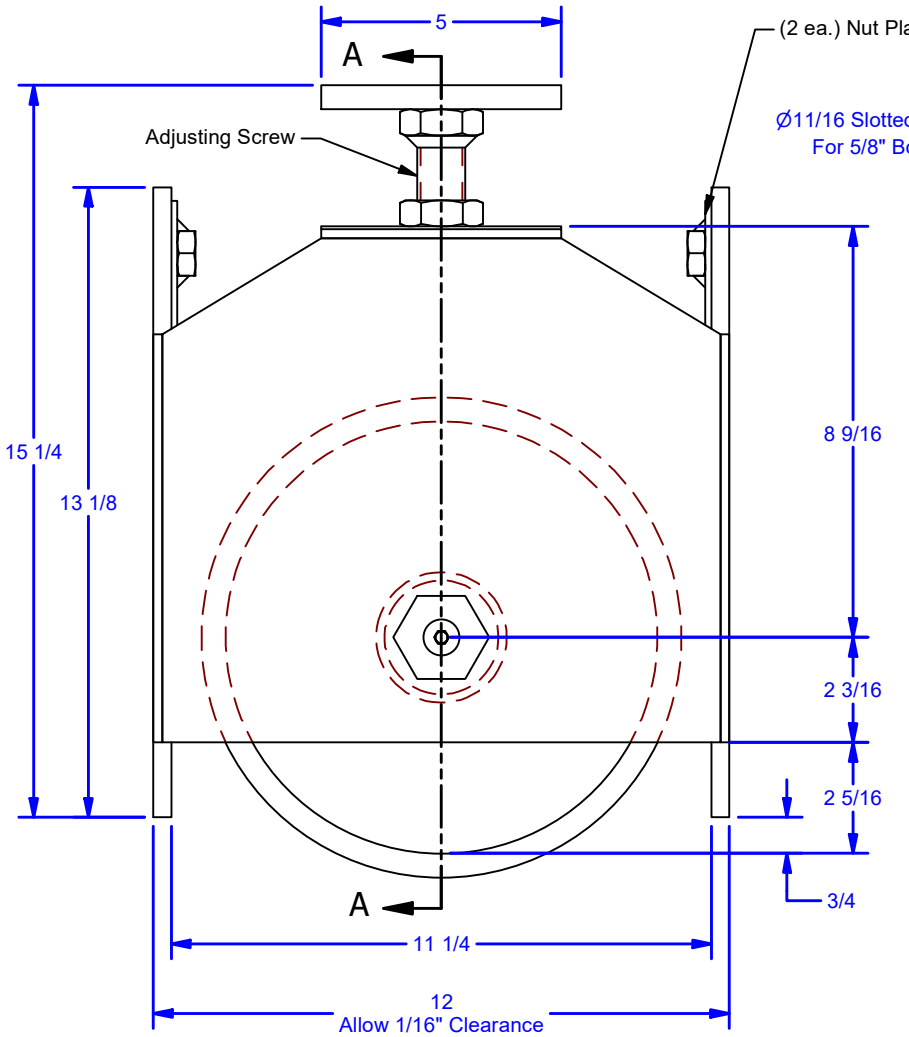

Ratings @ 10RPM
 Radial: 9,825 lbs.
 Thrust: 3,685 lbs.

ALL DIMENSIONS IN INCHES

THE INFORMATION CONTAINED IN THIS DRAWING IS THE SOLE PROPERTY OF CROWN INDUSTRIAL. ANY REPRODUCTION IN PART OR AS A WHOLE WITHOUT THE WRITTEN PERMISSION OF CROWN INDUSTRIAL IS PROHIBITED.

ID #: 0002013-02
 MATERIAL:

STOCK PART #: CR9-M

DESCRIPTION:
 9" Bottom Roller 7/16" Male Flange for 4" Thk Door

FINISH: Ptd. Black

PCS: 1
 REV:



CROWN INDUSTRIAL
 So. San Francisco, Ca
 (650) 952-5150
 www.crown-industrial.com

DWG #: 0000946
 DRAWN: BCM 5/21/2015
 SHEET #6
 File: 0000946.idw

4

3

2

1

4

3

2

1