

CRS142

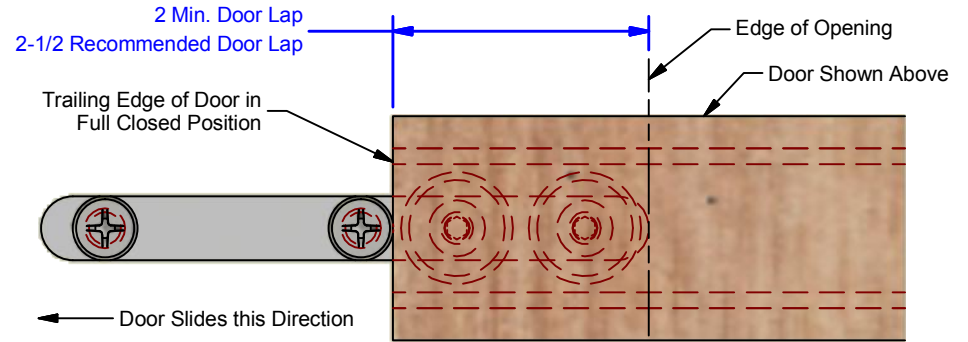

PLAN VIEW

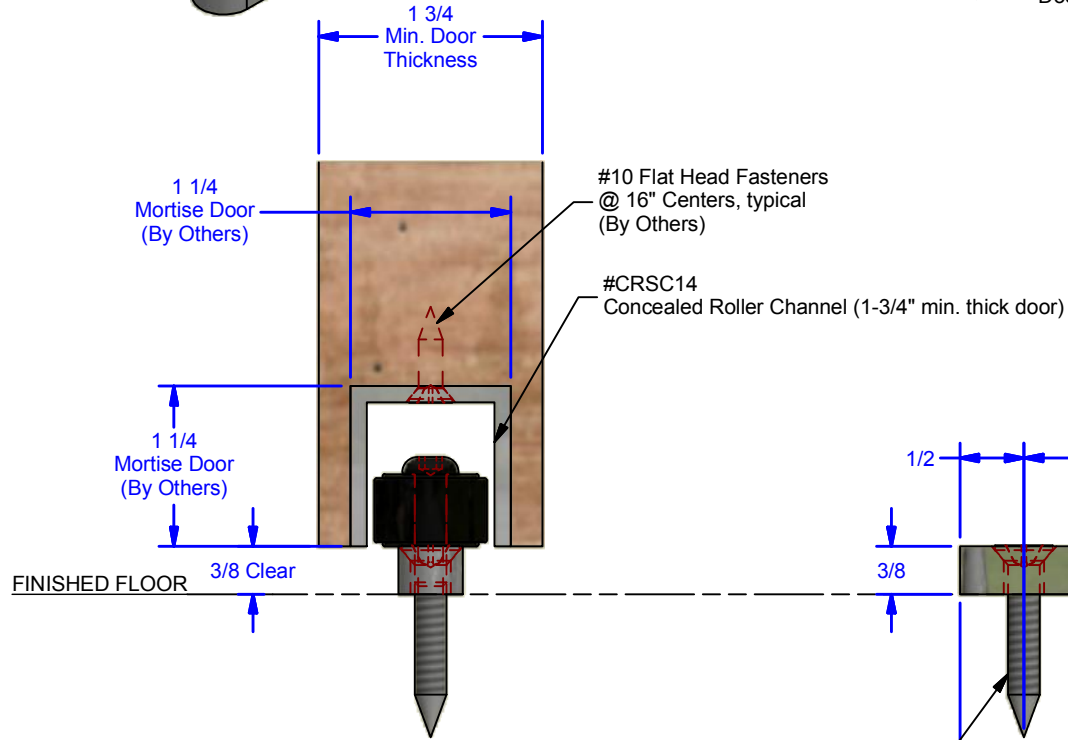

END VIEW

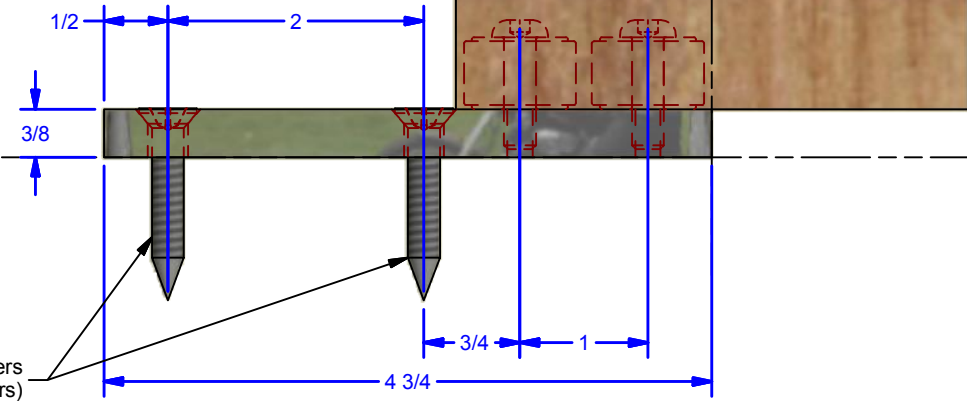

ELEVATION VIEW

Available Finishes:

- CRS142-Z: Clear Zinc w. Black Oxide Wheel
- CRS142-BZ: Black Zinc w. Black Oxide Wheel
- CRS142-S: 304 Stainless Steel w. #4 Brushed Finish w. Black Oxide Wheel
- CRS142-S-S: 304 Stainless Steel w. #4 Brushed Finish w. Stainless Steel Wheel.

DWG #: 0000504
 DRAWN:BCM 3/10/2015
 SHEET #4
 File: 0000504.idw

ALL DIMENSIONS IN INCHES

THE INFORMATION CONTAINED IN THIS DRAWING IS THE SOLE PROPERTY OF CROWN INDUSTRIAL. ANY REPRODUCTION IN PART OR AS A WHOLE WITHOUT THE WRITTEN PERMISSION OF CROWN INDUSTRIAL IS PROHIBITED.	ID #:	STOCK PART #:
	0001939	CRS142
DESCRIPTION:		
Concealed Stay Roller, 2 Wheel		
FINISH:	# PCS:	REV:



CROWN INDUSTRIAL

So. San Francisco, Ca
 (650) 952-5150
 www.crown-industrial.com