

REVISIONS			
REV.	DESCRIPTION	DATE	APPROVED

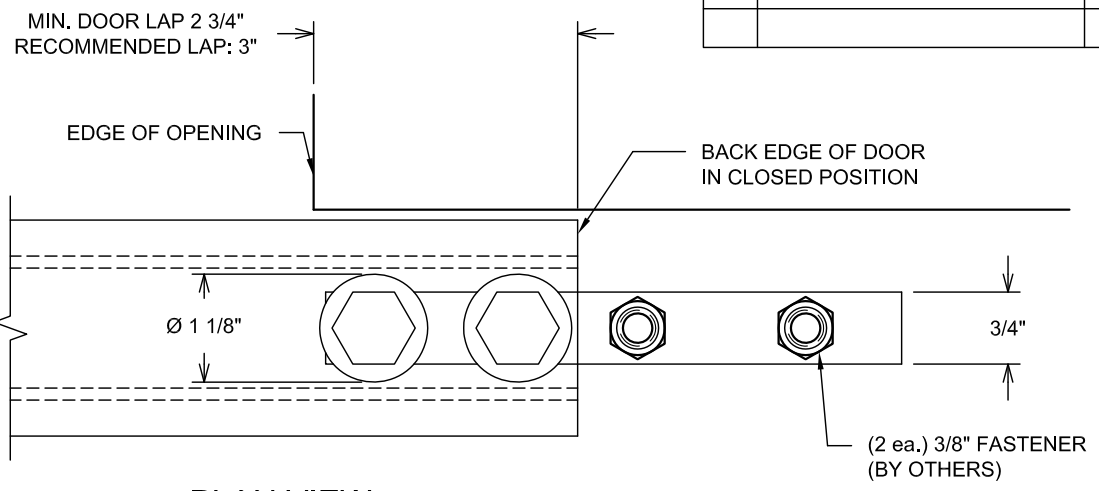

**PLAN VIEW**

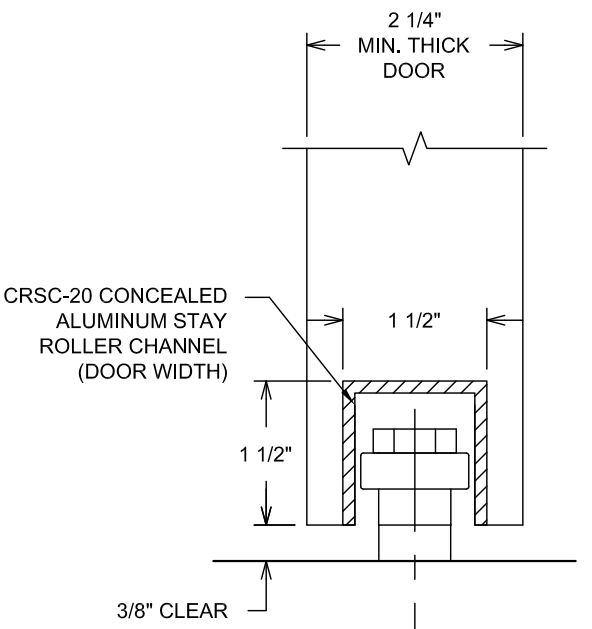

**END VIEW**

\*fasteners not shown for clarity

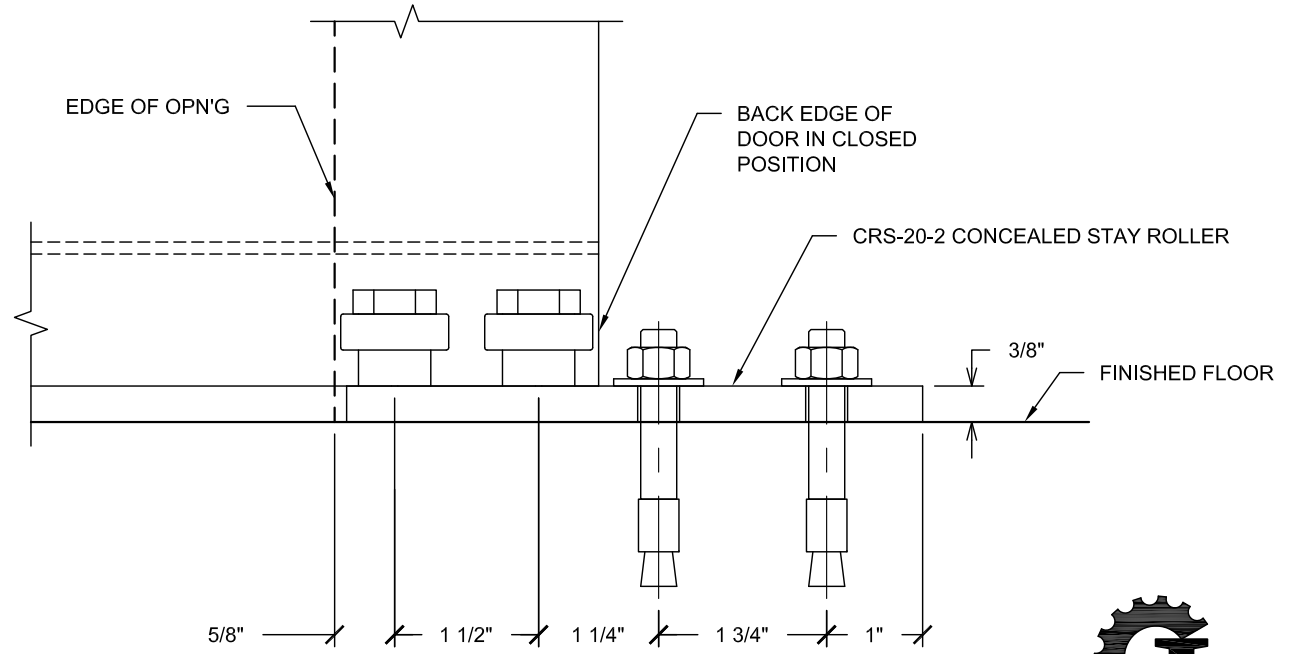

**ELEVATION VIEW**

- CRS-20-2 AVAIL. FINISHES:
- US2C ZINC PLTD.
  - BLACK ZINC PLTD.
  - STAINLESS STEEL
  - PTD. BLACK
  - PTD. TAN

THE INFORMATION CONTAINED IN THIS DRAWING IS THE SOLE PROPERTY OF CROWN INDUSTRIAL. ANY REPRODUCTION IN PART OR AS A WHOLE WITHOUT WRITTEN PERMISSION OF CROWN INDUSTRIAL IS PROHIBITED.



**CROWN INDUSTRIAL SUPPLY**  
SO. SAN FRANCISCO, CA  
(650)952-5150

DWG #CRS-20-2  
DESCRIP: CONCEALED STAY ROLLER TWO WHEEL ASSY, 2-1/4" THICK DOOR  
MIN. DOOR THICKNESS 2-1/4"  
DRAWN:BCM 01-28-10 REV:-----  
SCALE: 6" = 1'-0"  
SHEET # 1  
FILE:\\dc\userfolders\brian\my documents\inventor\designs\0000748