

Door (Shown Above)

Edge of Opening

3-1/4" Min. Door Lap  
4" Recommended Door Lap

Trailing Edge of Door in Full Closed Position

Door Slides This Direction →

2 3/4 Min. Thick Door  
4 Max. Thick Door

2 Mortise Door (By Others)

1/4" Flat Head Fasteners  
@ 24" Centers, Typical (By Others)

#CRSC-22  
Continuous Concealed Stay Roller Channel  
2"x2"x1/4" Alum. Channel-6063  
(Mortise or attach to bottom of door)

2 Mortise Door  
(By Others)

Face of Wall

1/2 Min. Clear

3/8 Min. Clear  
3/4" Max. Clear

1 1/4

1-1/2" Min.  
2-1/2" Max.  
Adjustable

3 1/8

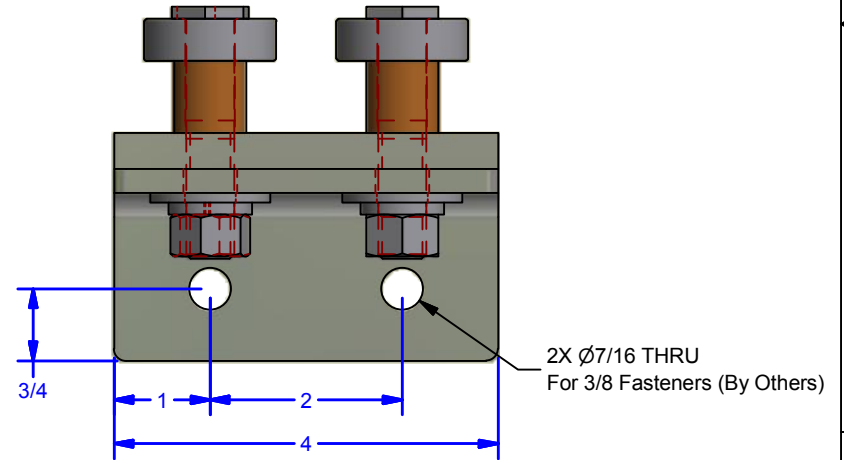

**ELEVATION (NO DOOR)**

2X Ø7/16 THRU  
For 3/8 Fasteners (By Others)

**END VIEW**

**ALL DIMENSIONS IN INCHES**

THE INFORMATION CONTAINED IN THIS DRAWING IS THE SOLE PROPERTY OF CROWN INDUSTRIAL. ANY REPRODUCTION IN PART OR AS A WHOLE WITHOUT THE WRITTEN PERMISSION OF CROWN INDUSTRIAL IS PROHIBITED.

ID #:	0002326	STOCK PART #:	CRS22x12
MATERIAL:			

DESCRIPTION:

Wall Mounted Concealed Stay DOUBLE Roller

FINISH:	Clear Zinc	# PCS:	1	REV:	
---------	------------	--------	---	------	--



**CROWN INDUSTRIAL**

So. San Francisco, Ca  
(650) 952-5150

www.crown-industrial.com

DWG #: 0000065  
DRAWN:BCM 8/24/2016  
SHEET #3

File: 0000065.idw