

CRS26

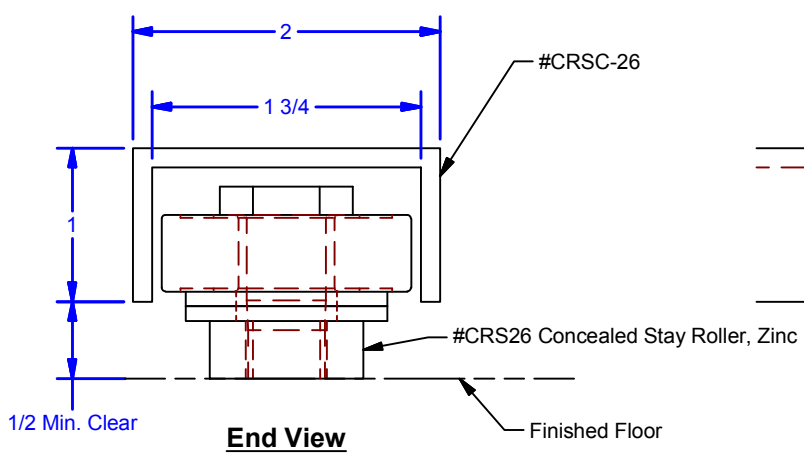

End View

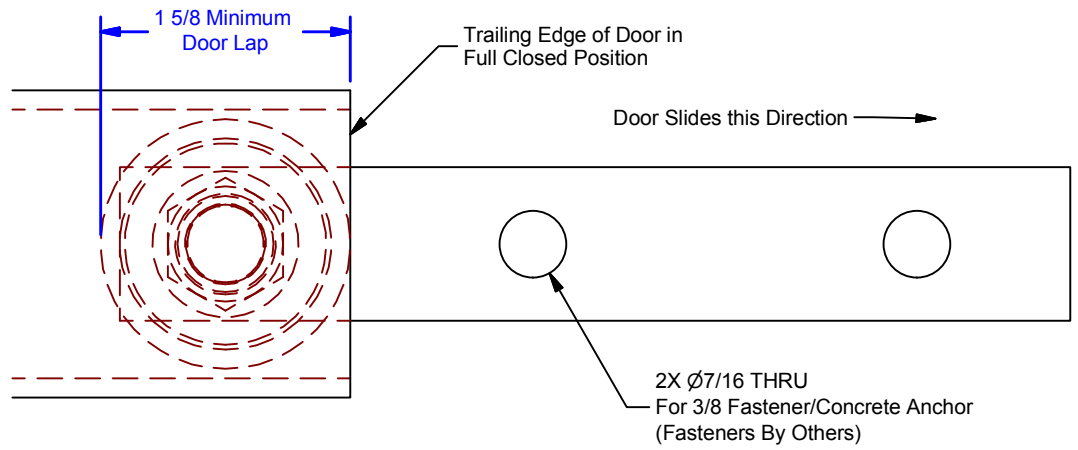
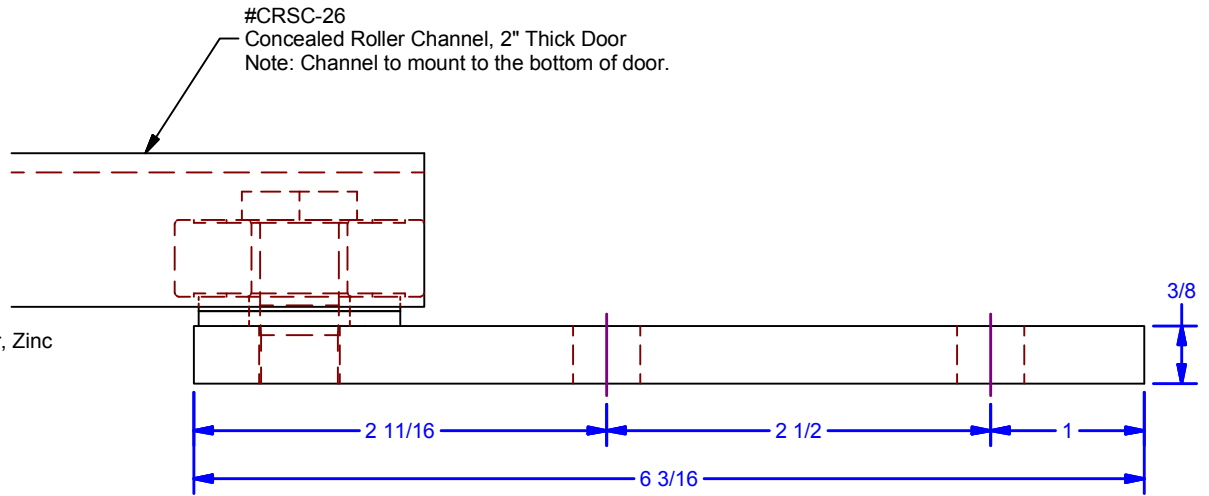

Elevation View

ALL DIMENSIONS IN INCHES

THE INFORMATION CONTAINED IN THIS DRAWING IS THE SOLE PROPERTY OF CROWN INDUSTRIAL. ANY REPRODUCTION IN PART OR AS A WHOLE WITHOUT THE WRITTEN PERMISSION OF CROWN INDUSTRIAL IS PROHIBITED.

DESCRIPTION:

Concealed Stay Roller

FINISH:
Clear Zinc

ID #:
0002088

MATERIAL:

STOCK PART #:
CRS26

# PCS:	1
REV:	



CROWN INDUSTRIAL

So. San Francisco, Ca
(650) 952-5150

www.crown-industrial.com

DWG #: CRS-26
DRAWN:BCM 8/20/2015
SHEET #1

File: 0000198.idw