

CTG-160

Trailing Edge of Door In Full Closed Position
 ← Door Slides this Direction

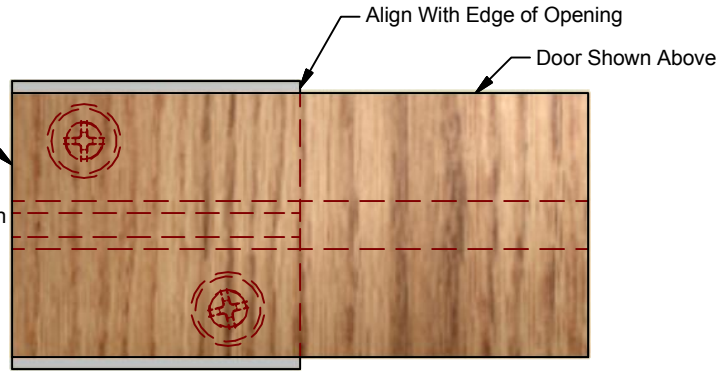

PLAN VIEW

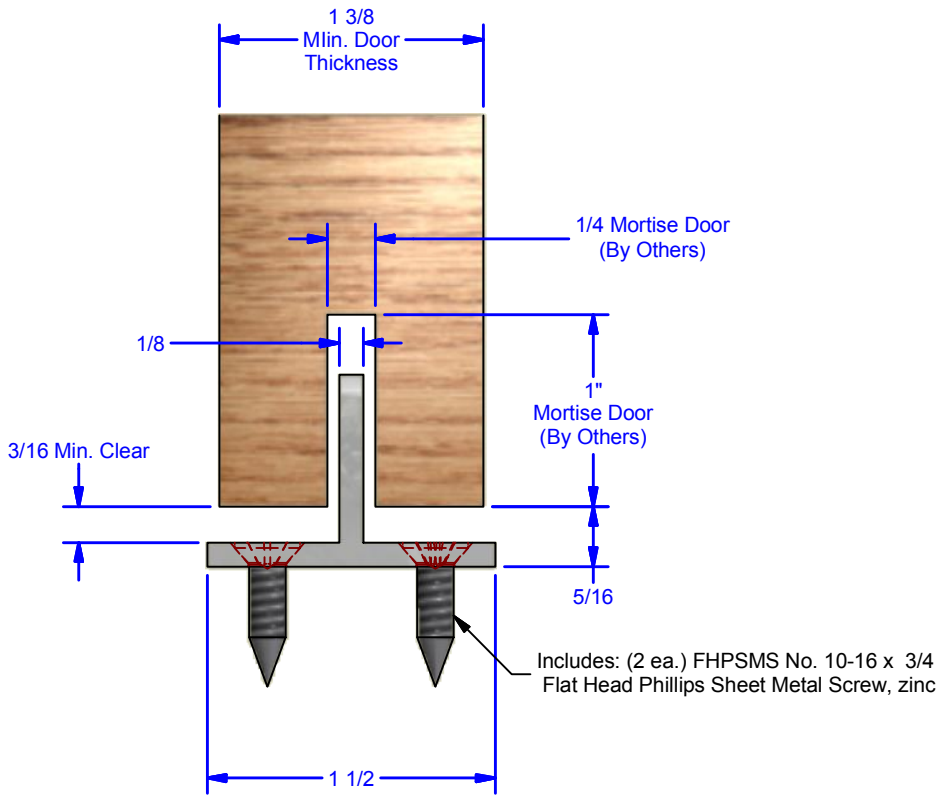

END VIEW

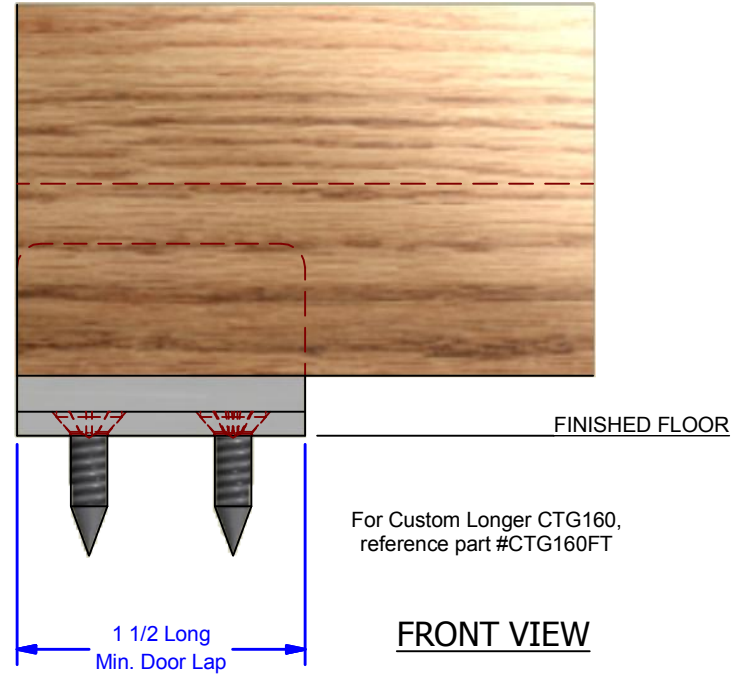

FRONT VIEW

ALL DIMENSIONS IN INCHES

THE INFORMATION CONTAINED IN THIS DRAWING IS THE SOLE PROPERTY OF CROWN INDUSTRIAL. ANY REPRODUCTION IN PART OR AS A WHOLE WITHOUT THE WRITTEN PERMISSION OF CROWN INDUSTRIAL IS PROHIBITED.

ID #: 0000338

STOCK PART #: CTG160

MATERIAL:

DESCRIPTION:

Concealed T-Guide

FINISH: Clear Ano. Alum. MILL FINISH

# PCS:	1
REV:	



CROWN INDUSTRIAL

So. San Francisco, Ca
 (650) 952-5150

www.crown-industrial.com