

**CTG-160HD**

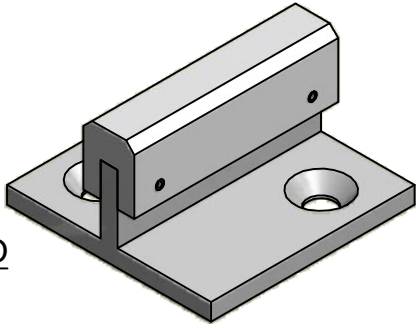

**PLAN VIEW**

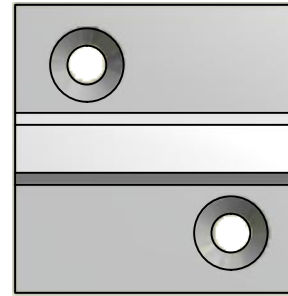

(Door not shown above for clarity)

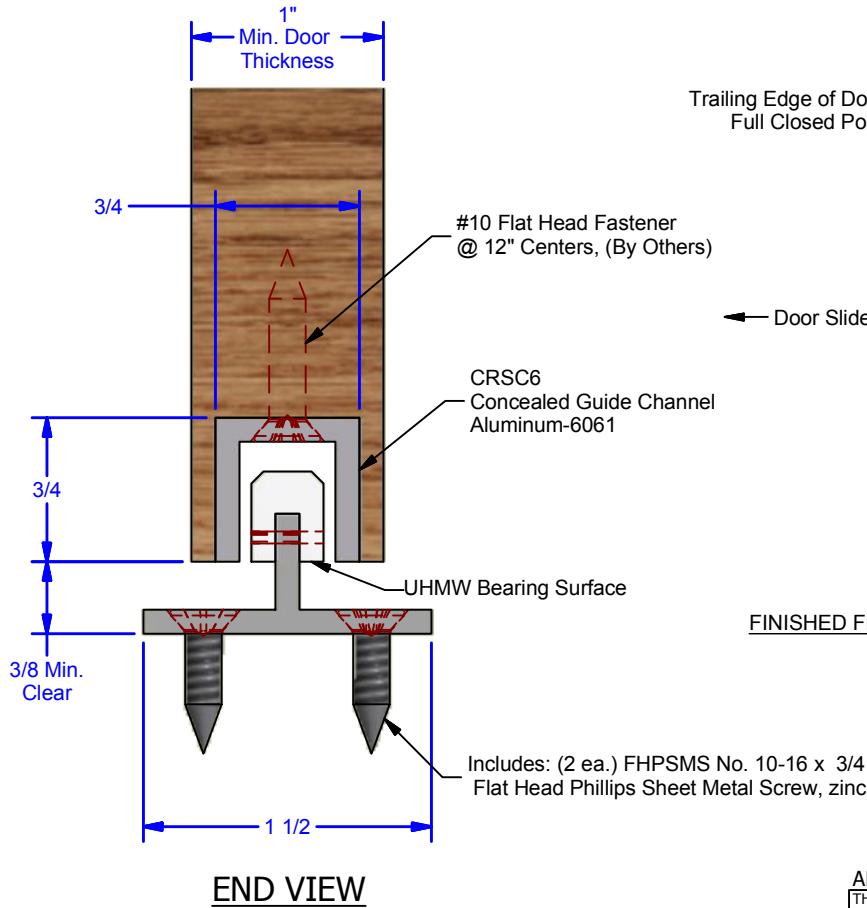

Trailing Edge of Door In Full Closed Position

Door Slides this Direction

FINISHED FLOOR

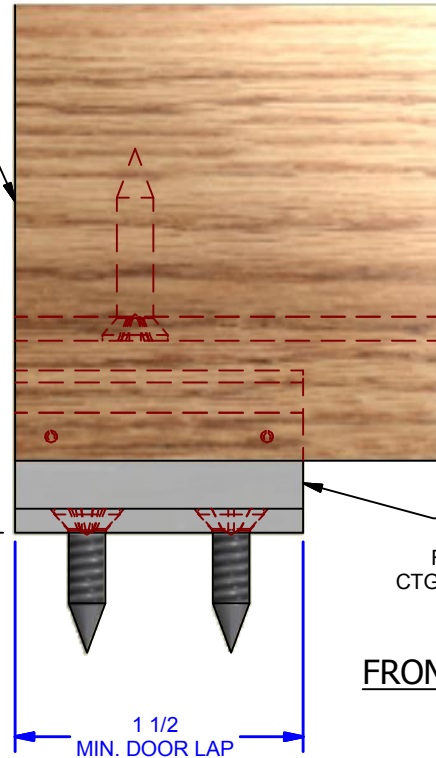

ALL DIMENSIONS IN INCHES

THE INFORMATION CONTAINED IN THIS DRAWING IS THE SOLE PROPERTY OF CROWN INDUSTRIAL. ANY REPRODUCTION IN PART OR AS A WHOLE WITHOUT THE WRITTEN PERMISSION OF CROWN INDUSTRIAL IS PROHIBITED.	ID #:	0000345	STOCK PART #:	CTG160HD
	MATERIAL:	Aluminum		
DESCRIPTION: Heavy Duty Concealed T Guide Assy.				
FINISH:	Mill	# PCS:	1	REV:



**CROWN INDUSTRIAL**

So. San Francisco, Ca  
(650) 952-5150

www.crown-industrial.com

DWG #: 0000340  
DRAWN:BCM 3/12/2008  
SHEET #5

File: 0000340.idw