

STANDARD HEAD SECTION  
USING SIDEWALL BRACKET

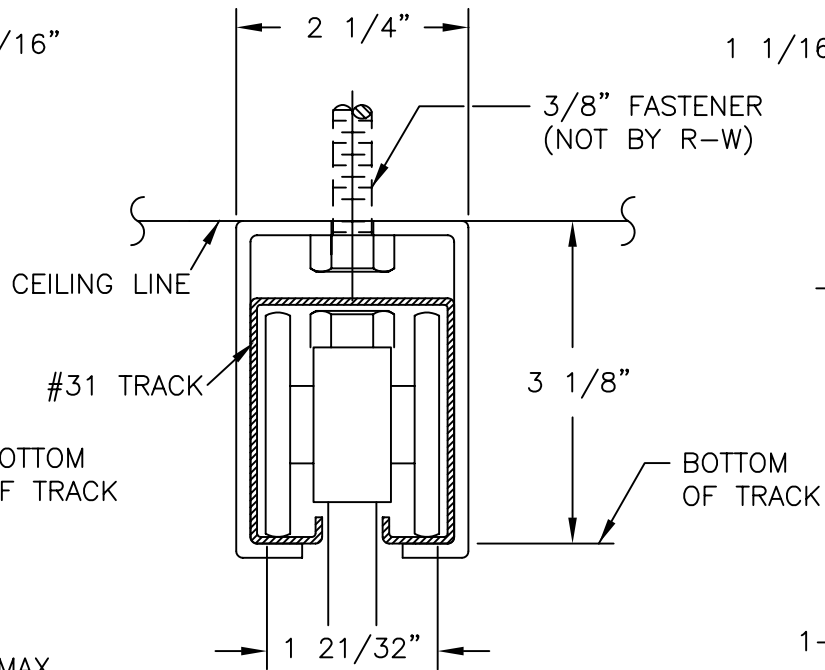

STANDARD HEAD SECTION  
USING OVERHEAD BRACKET

