

DETAIL A

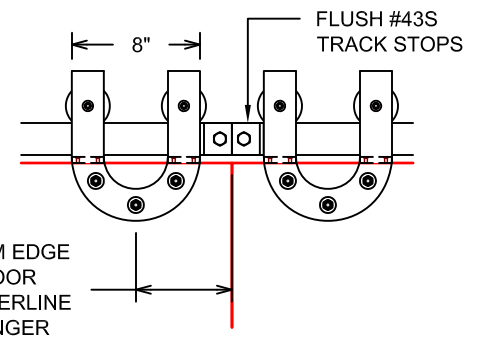

DETAIL B

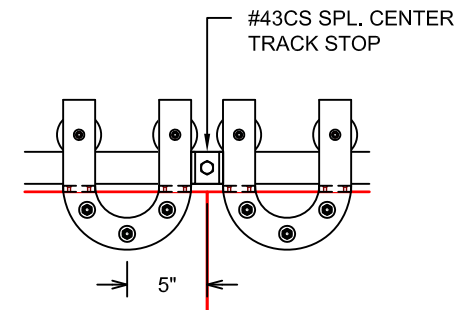

DETAIL C

INDICATE:

1. OPENING WIDTH:
2. DOOR WIDTH:
3. DOOR THICKNESS:
4. FROM THE EDGE OF THE DOOR TO THE CENTERLINE OF THE FLAT TRACK HANGER:
5. PROJECTION OF MATERIALS BEYOND WALL BLOCKING: (FOR WALL SPACER LENGTH- SEE SHEET 2)
6. FIELD OR FACTORY DRILL TRACK MOUNTING HOLES:

43 FLAT TRACK
 DESCRIP: Flat Track Elevation - 43U Biparting (500LB CAPACITY)
 DRAWN:BCM 10-23-09
 SCALE: NONE
 SHEET # 1

FILE:z:\engineering\hardware\43flat\flat track template\flat track customer template 10-23-09

THE INFORMATION CONTAINED IN THIS DRAWING IS THE SOLE PROPERTY OF CROWN INDUSTRIAL. ANY REPRODUCTION IN PART OR AS A WHOLE WITHOUT WRITTEN PERMISSION OF CROWN INDUSTRIAL IS PROHIBITED.



CROWN INDUSTRIAL

So. San Francisco, Ca
 (650) 952-5150

www.crown-industrial.com

REVISIONS			
REV.	DESCRIPTION	DATE	APPROVED

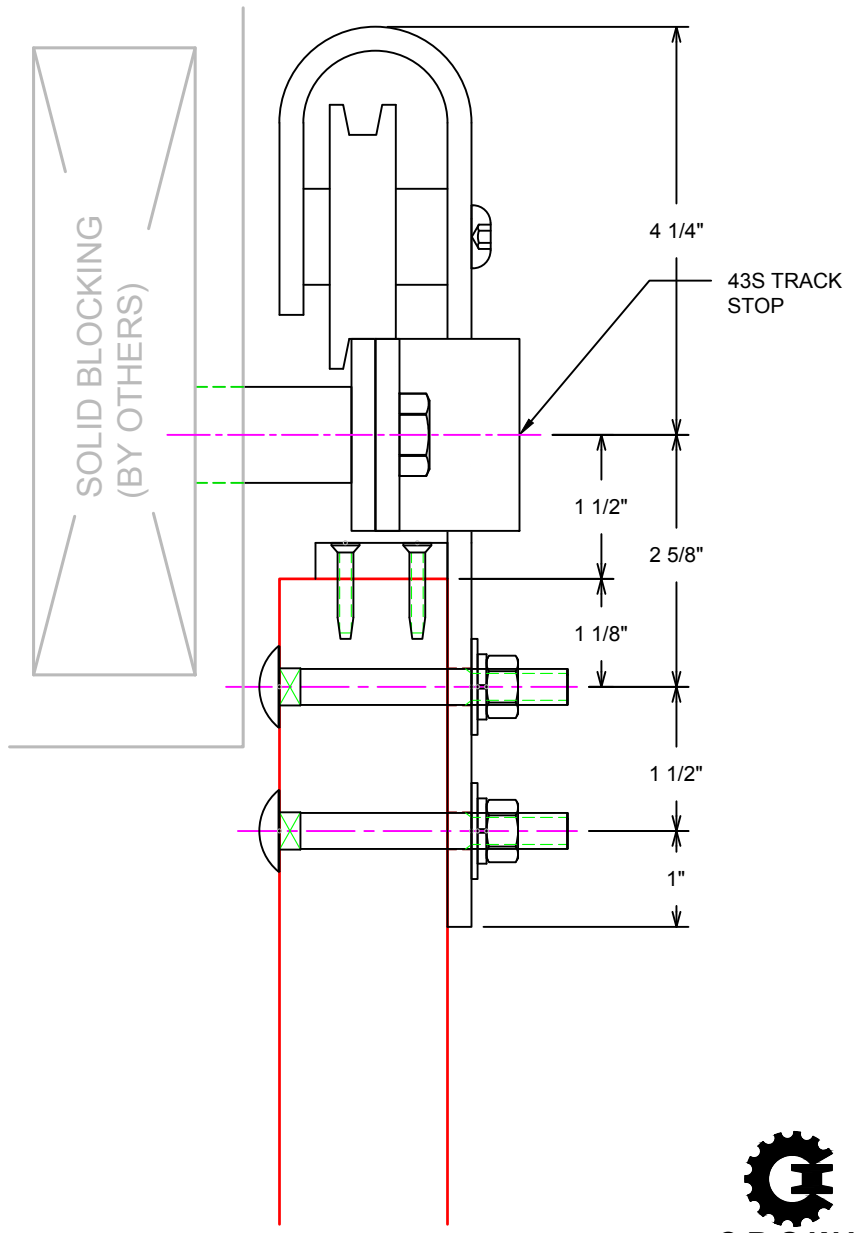
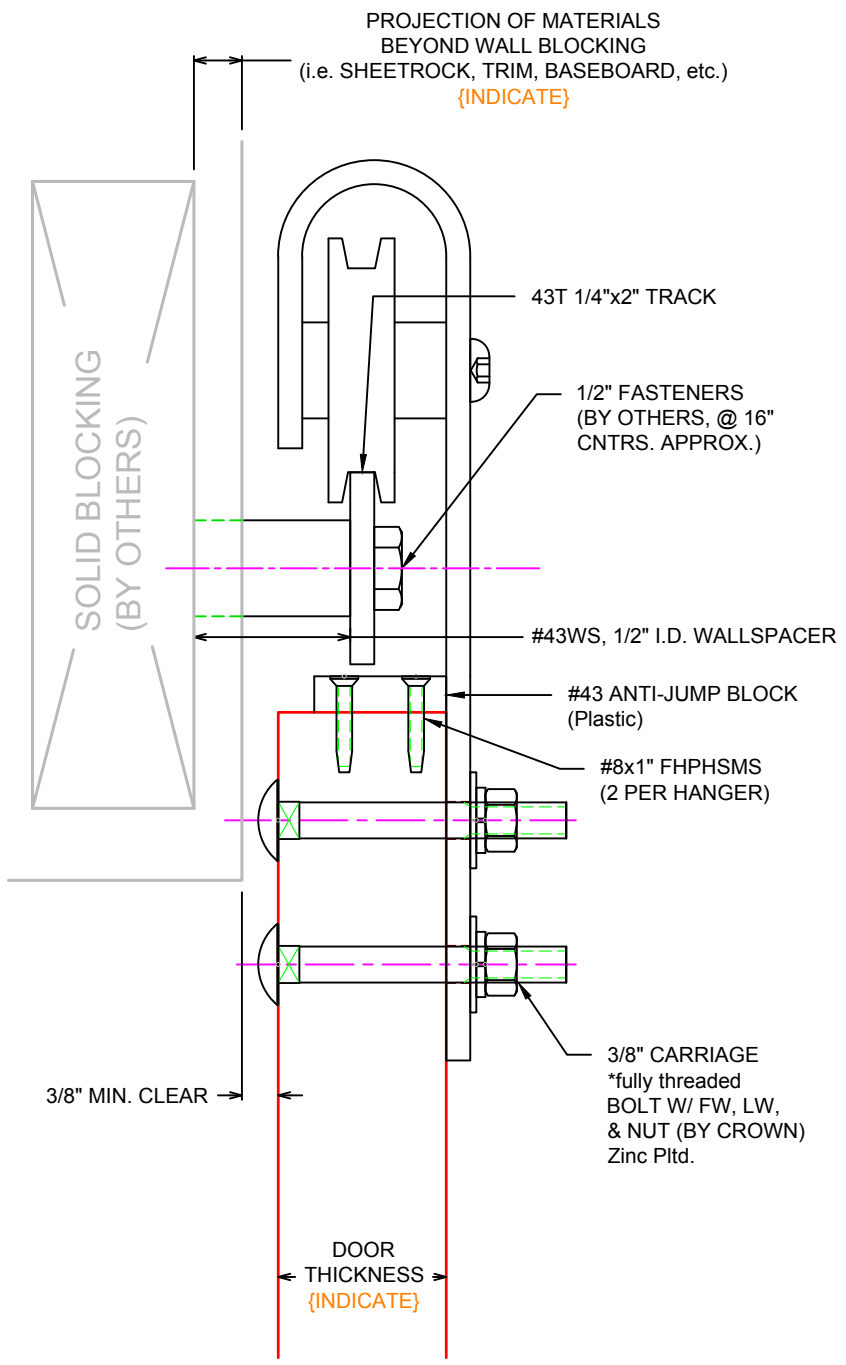

43 FLAT TRACK
 DESCRIP: 43U Flat Track Head Section
 DRAWN:BCM 10-23-09 REV:-----
 SCALE: NONE
 SHEET # 2

FILE: \\crown-fs\main\engineering\hardware\43flat\flat track template\flat track customer template 10-23-09

THE INFORMATION CONTAINED IN THIS DRAWING IS THE SOLE PROPERTY OF CROWN INDUSTRIAL. ANY REPRODUCTION IN PART OR AS A WHOLE WITHOUT WRITTEN PERMISSION OF CROWN INDUSTRIAL IS PROHIBITED.

CROWN INDUSTRIAL
 So. San Francisco, Ca
 (650) 952-5150
 www.crown-industrial.com

4

3

2

1

D

D

C

C

B

B

A

A

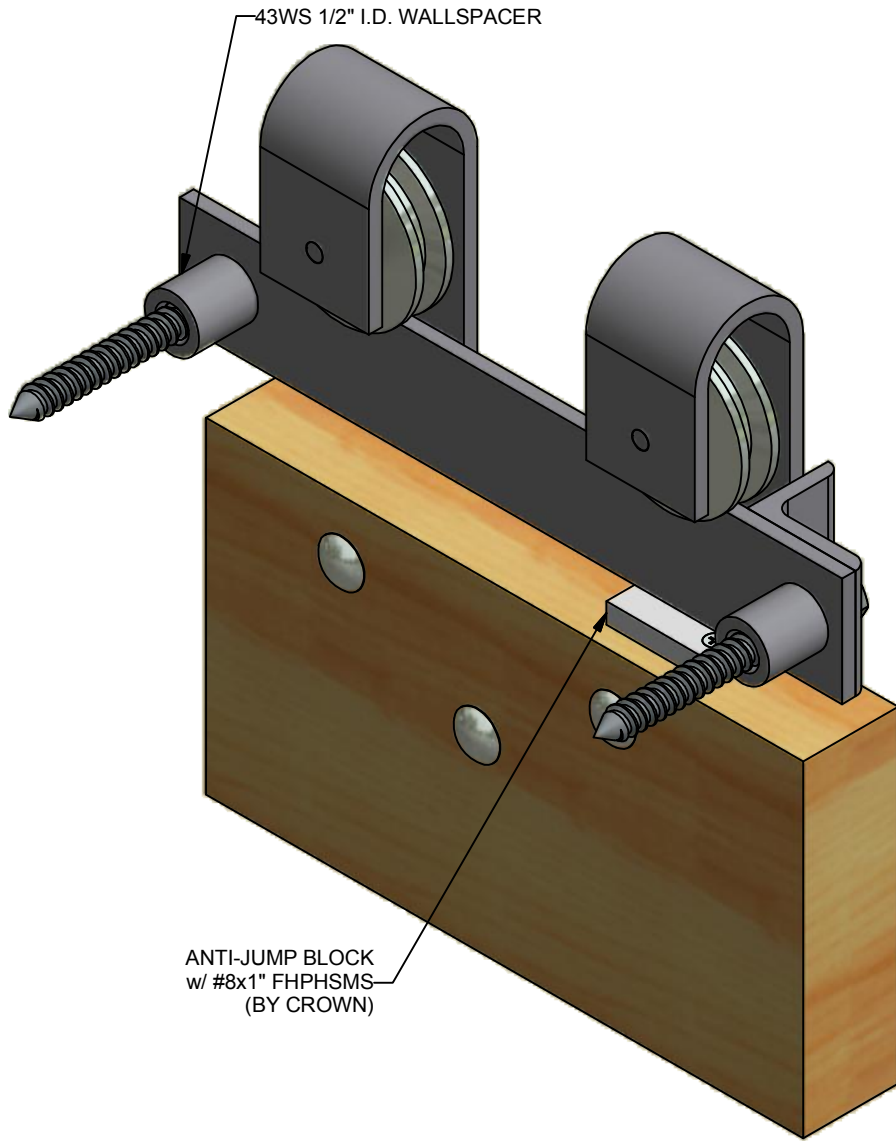

BACK/WALLSIDE VIEW

NOTE: ALL WALLSPACERS MUST COME IN DIRECT CONTACT WITH SOLID BLOCKING

43S TRACK STOP

1/2" FASTENER (BY OTHERS, TYPICAL)

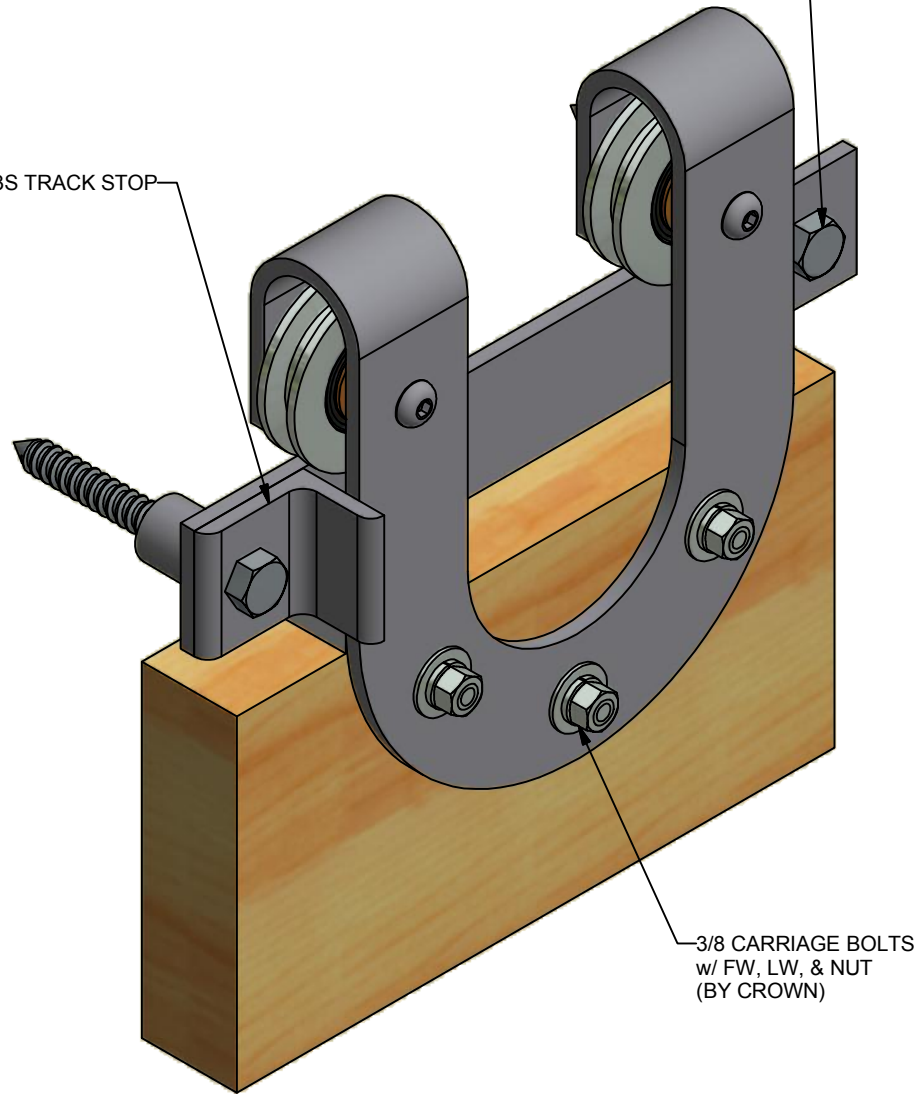

FRONT VIEW

ALL DIMENSIONS IN INCHES

THE INFORMATION CONTAINED IN THIS DRAWING IS THE SOLE PROPERTY OF CROWN INDUSTRIAL. ANY REPRODUCTION IN PART OR AS A WHOLE WITHOUT THE WRITTEN PERMISSION OF CROWN INDUSTRIAL IS PROHIBITED.

DESCRIPTION:

#43 "U" FLAT TRACK ASSEMBLY

FINISH:

Specify

ID #: 0000316

MATERIAL:

STOCK PART #:

43U

PCS: 2

REV:



CROWN INDUSTRIAL

So. San Francisco, Ca
(650) 952-5150

www.crown-industrial.com

DWG #: 43H
DRAWN: BCM 12/15/2008
SHEET #3

File: 0000316.idw

4

3

2

1

