

REVISIONS			
REV.	DESCRIPTION	DATE	APPROVED

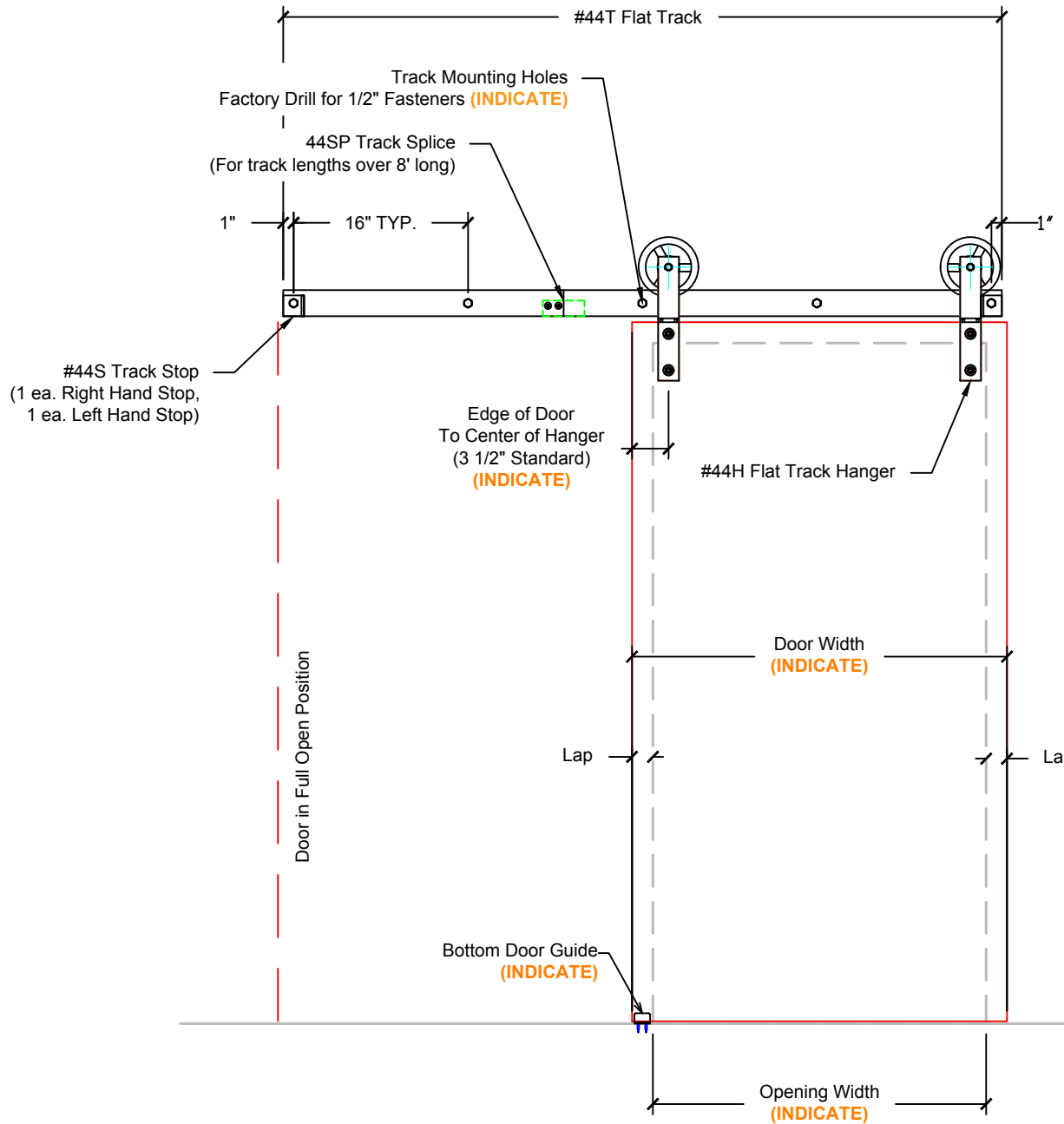

INDICATE:

1. OPENING WIDTH:
2. DOOR WIDTH:
3. DOOR THICKNESS:
4. EDGE OF DOOR TO CENTER OF HANGER:
5. PROJECTION OF MATERIALS BEYOND WALL BLOCKING:
(FOR WALL SPACER LENGTH-SEE SHEET 2)
6. FIELD OR FACTORY DRILLED TRACK MOUNTING HOLES

44 FLAT TRACK
 DWG #44H
 DESCRIP: 44H ELEVATION-SINGLE SLIDE
 DRAWN:BCM 8-14-08
 SCALE: NONE
 SHEET # 1

FILE: \\crown-fs\main\engineering\hardware\44\44 customer template

THE INFORMATION CONTAINED IN THIS DRAWING IS THE SOLE PROPERTY OF CROWN INDUSTRIAL. ANY REPRODUCTION IN PART OR AS A WHOLE WITHOUT WRITTEN PERMISSION OF CROWN INDUSTRIAL IS PROHIBITED.



CROWN INDUSTRIAL

So. San Francisco, Ca
 (650) 952-5150
 www.crown-industrial.com

Projection of Materials
Beyond Wall Blocking
(i.e. Sheetrock, Trim, Baseboard)
(INDICATE)

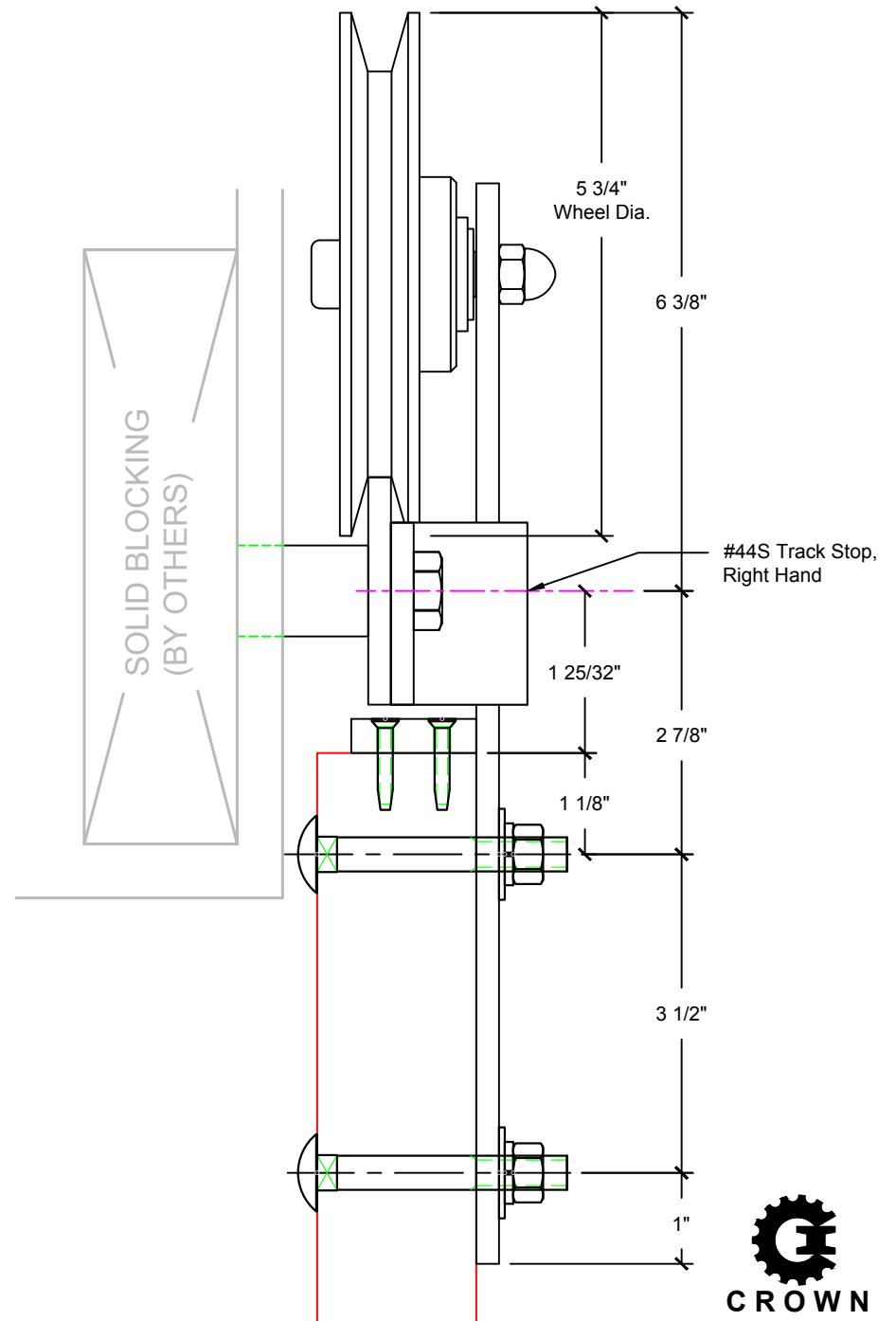
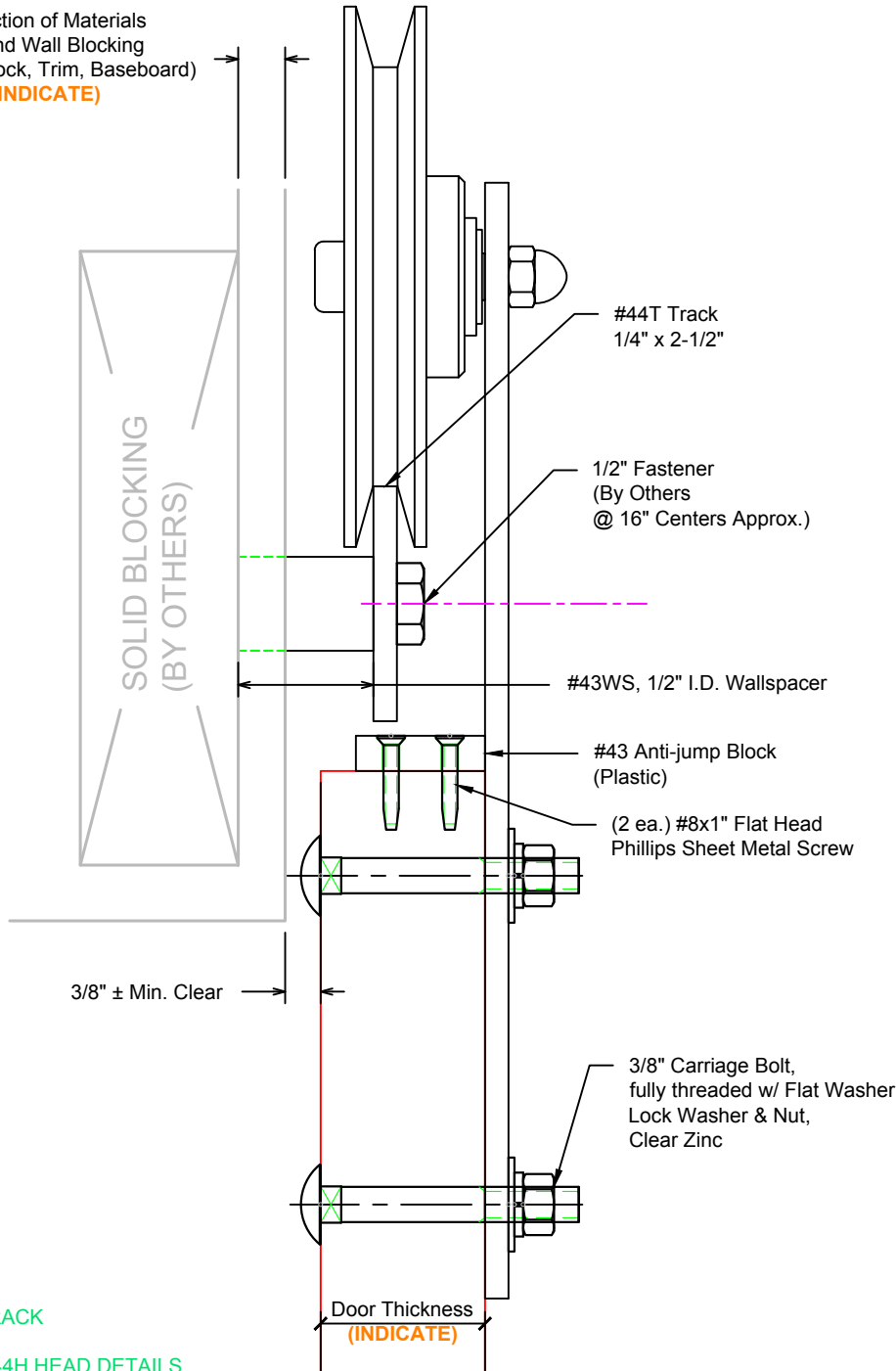

44 FLAT TRACK
DWG #44H
DESCRIP: 44H HEAD DETAILS
DRAWN:BCM 8-14-08
SCALE: NONE
SHEET # 2

FILE: \\crown-fs\main\engineering\hardware\44\44 customer template

THE INFORMATION CONTAINED IN THIS DRAWING IS THE SOLE PROPERTY
OF CROWN INDUSTRIAL. ANY REPRODUCTION IN PART OR AS A WHOLE
WITHOUT WRITTEN PERMISSION OF CROWN INDUSTRIAL IS PROHIBITED.



**CROWN
INDUSTRIAL**

So. San Francisco, Ca
(650) 952-5150
www.crown-industrial.com